



TOOL SOLUTIONS FOR MAXIMUM
PRODUCTIVITY AND SAFETY



SMART SOLUTIONS FOR ALL PROFESSIONS

Safety and productivity are now of paramount importance to industrial professions. The annual estimated impact of FOD (Foreign Object Damage) comes to \$13 Bn, with indirect costs often exceeding direct costs. This observation is valid for all sectors, resulting from material and human accidents, production stoppages, late deliveries, etc.

PRE-SHAPED FOAM MODULES

A precious visual aid for instant tool inventory and presence check in your roller cabinet.



FACOM





FACOM • FLUO RANGE

- Detectable with a UV lamp, the Fluo range is a simple and unique answer to find your tools when working in dark areas.
- A solution reinforcing safety by reducing the risks of accidents due to lost tools.
- Over 400 product references in the range.

FACOM FLUO



RFID TECHNOLOGY

- Tools directly detectable thanks to a seamlessly integrated chip.
- Optimised traceability, no more lost tools in sensitive areas.
- Automated management of your tooling and its inventory with RFID Facom-Cribmaster technologies.
- A range of over 700 product references.

FACOM RFID **CribMaster**

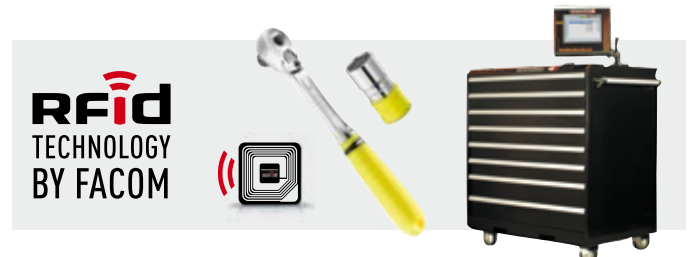

A RANGE OF TOOLS AT THE FOREFRONT OF INNOVATION

RFID
TECHNOLOGY
BY FACOM



CribMaster

The RFID technology (Radio Frequency Identification) ensures remote tool identification by means of its built-in electronic chip. The latter uses energy propagated at short distances by the radio transmitter signal: no batteries required. Invisible and tough, RFID chips guarantee optimum operation for many years. The radio technology used has no impact on the external environment.





CHIP SEAMLESSLY INTEGRATED TO THE TOOL

For each tool, the Facom Engineers have integrated the RFID chip guaranteeing the best possible data transmission. Encapsulated under an anti-shock shell, the chip is protected durably, including from chemical agents, without altering the tool's basic characteristics or its ergonomics.



MULTIPLE BENEFITS IN THE WORKSHOP

- High quality chips programmed to guarantee the best detection.
- Tools traceable in the workshop by zones of use.
- Fluorescent tools can be found up to 3 meters away in dark areas.
- Broad range covering all applications.

CribMaster

RFID
TECHNOLOGY
BY FACOM



For more information on the RFID technology:
www.facom.fr



Synergy between the Facom and Cribmaster brands from the Stanley Black&Decker group allowed the most advanced solution in the market for tooling traceability to be developed: tools, roller cabinets, zoning terminals, management software. As practices or risks are not the same in all companies, our advisors tailor your RFID solution to your requirements.

BOOSTING YOUR PRODUCTIVITY

Your roller cabinets are operational as of their installation. The roller cabinet is supplied with its tools organised in customised foam modules. The software can be configured to meet your requirements:

- Tool entry-exit recording.
- Automatic inventory.
- Customised access control with restricted access possible.
- Tool localisation by workshop zone.



Two brands from the Industrial & Automotive Repair division of the Stanley Black&Decker group.

CUTTING EDGE TECHNOLOGY FOR SAFETY AND PRODUCTIVITY

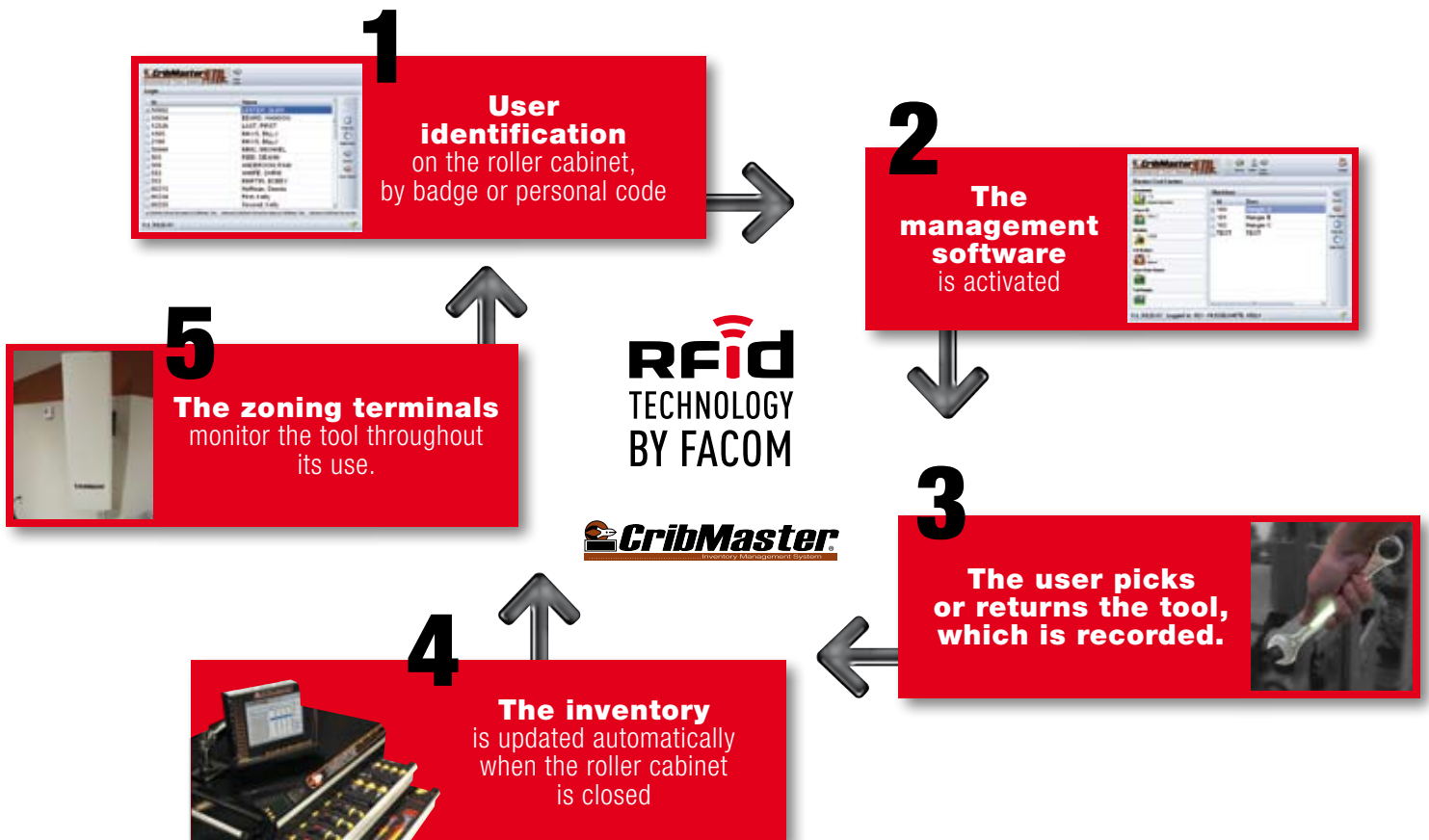



ALWAYS A FACOM TOOL SUITED TO YOUR NEEDS

In fields such as nuclear, power grids, wind generators, drilling platforms, aerospace, or naval construction or repair, Facom develops on-demand securing solutions.

FACOM FOREIGN MATERIAL EXCLUSION SECURES YOUR TOOLS FOR WORKING AT HEIGHT.

For your teams working at height, Facom offers securing cords built into the tools and complying with their original ergonomics of use.

By preventing falling tools, they offer a considerable benefit in terms of productivity and safety.



Tools and roller cabinet developed upon request from EDF



- **Your workshop in your color scheme.**
- **Tool organisation modules** adapted per product selection.
- **Workshop roller cabinets** with specific drawer assortments.
- **Special bits** for torque wrenches.
- **Finish** and marking of specific products.
- **Change** of material.



Contact:
Services outils spéciaux
+33 (0)1 64 54 46 70
Fax: +33(0)1 69 74 29 04
Monday to Friday from 8:15 to 12:15 and 13:30 to 17:00



CLOSE TO YOUR NEEDS, ALL OVER THE WORLD

Wherever you operate, our international distribution network and our partners offer access to the best tooling and all the FACOM services you need.









FACOM CUSTOMERS INCLUDE

AIR FRANCE, ALSTOM,
AREVA, BOMBARDIER, EADS,
EDF, PEUGEOT CITROËN,
RENAULT NISSAN,
ROLLS-ROYCE, SAFRAN,
THALES, TOTAL, TOYOTA,
VALEO, VINCI.

FACOM.RFID

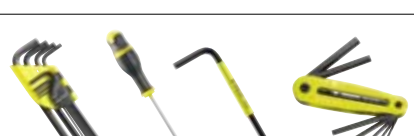
▶ 1	Fixed and variable opening wrenches		12		RFID
▶ 2	Ratchets - Sockets		21		RFID
▶ 3	Torque control		36		RFID
▶ 4	Screwdrivers - Keys		38		RFID
▶ 5	Pliers		42		RFID
▶ 6	Measuring - Hammers - Cutting		52		RFID

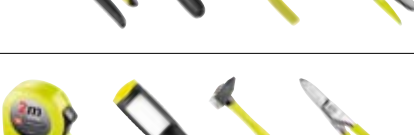
FACOM.FLUO

▶ 7	Fixed and variable opening wrenches		59		FLUO
▶ 8	Ratchets - Sockets		63		FLUO
▶ 9	Screwdrivers - Keys		68		FLUO
▶ 10	Pliers		74		FLUO
▶ 11	Measuring - Hammers - Lighting		82		FLUO

Combination wrenches

Solutions FACOM.RFID

PRODUCTIVITY AND SAFETY

RFID
TECHNOLOGY
BY FACOM



For further information on RFID technology, scan this QR code with your smartphone or your tablet.

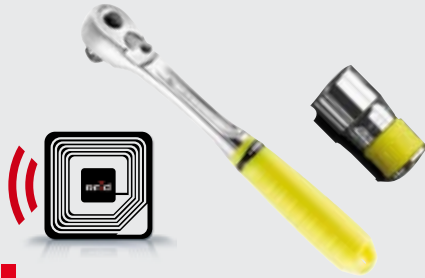

www.facom.com

Combination wrenches

440 - Metric combination wrenches - RFID

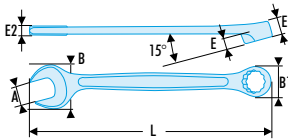

NF ISO 691, NF ISO 7738, NF ISO 3318, NF ISO 1711-1, E74-306, ISO 691, ISO 7738, ISO 3318, ISO 1711-1, DIN ISO 691, DIN ISO 1711-1, DIN 3113, ASME B107.100

- Tool with built-in RFID chip for workshop traceability.
- Chip integration by Facom guarantees maximum detection and strength, while preserving the tool's ergonomics.
- Radio frequency identification requires appropriate storage equipment.
- Standard wrench for all current applications.
- High mechanical strength combined with compact size meeting aeronautical standards.
- Ring head:
 - Ring open end (size E) designed for better access to series or embedded screws.
 - OGV® profile with 12-point ring for powerful tightening while protecting the nut.
 - H suffix = 6-point ring.
 - Ring head angled at 15°.
- Open end head:
 - Open end angled at 15°.
 - Open end head-handle geometry optimised for increased access.
- Metric sizes: 5 to 41 mm.
- Presentation: satin chrome finish.



RFID	A [mm]	B [mm]	B1 [mm]	E [mm]	E1 [mm]	E2 [mm]	L [mm]	ΔΔ [g]
440.5HRFID	5	13,3	9,2	3,1	6,0	3,6	115	20
440.5.5HRFID	5,5	13,3	9,2	3,1	6,0	3,8	115	20
440.6RFID	6	14,1	10,0	3,1	6,0	3,8	115	25
440.7RFID	7	17,2	11,2	3,4	6,2	3,9	122	25
440.8RFID	8	19,2	12,8	3,5	6,7	4,7	133	35
440.9RFID	9	21,2	14,2	3,9	7,1	4,7	138	40
440.10RFID	10	23,0	15,0	4,2	7,6	5,2	145	45
440.11RFID	11	24,5	16,9	4,6	8,1	5,5	155	50
440.12RFID	12	27,0	18,0	4,4	8,4	5,8	162	65
440.13RFID	13	28,7	19,3	4,8	8,6	6,1	170	75
440.14RFID	14	31,0	21,1	5,7	9,5	6,4	180	90
440.15RFID	15	32,6	22,2	5,9	10,0	6,8	185	100
440.16RFID	16	35,6	23,9	6,4	10,5	7,3	195	120
440.17RFID	17	37,0	25,3	6,5	10,9	7,6	202	135
440.18RFID	18	38,7	26,0	7,2	11,4	8,1	208	160
440.19RFID	19	41,2	27,8	7,2	11,9	8,3	216	180
440.20RFID	20	43,1	29,5	6,3	12,3	8,6	224	195

RFID	A [mm]	B [mm]	B1 [mm]	E [mm]	E1 [mm]	E2 [mm]	L [mm]	ΔΔ [g]
440.21RFID	21	45,4	30,9	7,8	12,8	8,8	233	215
440.22RFID	22	46,9	32,3	8,3	13,3	9,0	248	240
440.23RFID	23	49,0	33,6	8,7	13,8	9,3	257	265
440.24RFID	24	51,0	35,0	8,9	14,2	9,7	267	300
440.25RFID	25	53,0	36,4	9,4	14,7	9,9	274	325
440.26RFID	26	55,5	37,8	9,8	15,1	10,1	285	355
440.27RFID	27	58,0	39,2	8,9	15,6	10,4	295	385
440.28RFID	28	60,7	40,6	10,6	16,1	10,7	305	425
440.29RFID	29	63,0	42,0	10,8	16,6	11,2	320	485
440.30RFID	30	65,0	43,5	11,2	17,1	11,5	340	540
440.32RFID	32	68,0	46,1	11,5	18,0	12,5	355	650
440.33RFID	33	69,8	47,0	11,8	18,5	12,8	380	425
440.34RFID	34	72,0	48,9	12,8	19,0	13,0	390	755
440.35RFID	35	74,3	51,0	12,8	19,5	13,5	430	900
440.36RFID	36	76,0	53,0	13,2	20,0	14,0	440	955
440.38RFID	38	80,0	56,0	14,1	22,0	15,2	450	1140
440.41RFID	41	85,0	58,3	14,7	23,0	16,0	460	1300

Combination wrenches

Fixed and variable opening wrenches

440 - Inch combination wrenches - RFID

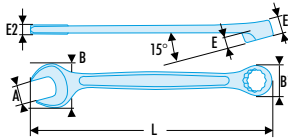

ASME B107.100, SAE AS954G

- Tool with built-in RFID chip for workshop traceability.
- Chip integration by Facom guarantees maximum detection and strength, while preserving the tool's ergonomics.
- Radio frequency identification requires appropriate storage equipment.
- Standard wrench for all current applications.
- High mechanical strength combined with compact size meeting aeronautical standards.
- Ring head:
 - Ring open end (size E) designed for better access to series or embedded screws.
 - OGV® profile with 12-point ring for powerful tightening while protecting the nut. H suffix = 6-point ring.
 - Ring head angled at 15°.
- Open end head:
 - Open end angled at 15°.
 - Open end head-handle geometry optimised for increased access.
- Dimensions in inches: from 1/4" to 1 1/2".
- Presentation: satin chrome finish.

⊞	A ["]	B [mm]	B1 [mm]	E [mm]	E1 [mm]	E2 [mm]	L [mm]	ΔΔ [g]
440.1/4RFID	1/4	14,1	10,0	3,1	6,0	3,8	115	25
440.5/16RFID	5/16	19,2	12,8	3,5	6,7	4,7	133	35
440.11/32RFID	11/32	21,2	14,2	3,9	7,1	4,7	138	40
440.3/8RFID	3/8	23,0	15,0	4,2	7,6	5,2	145	50
440.7/16RFID	7/16	24,5	16,9	4,6	8,1	5,5	155	55
440.1/2RFID	1/2	28,7	19,3	4,8	8,6	6,1	170	75
440.9/16RFID	9/16	31,0	21,1	5,7	9,5	6,4	180	90
440.5/8RFID	5/8	35,6	23,9	6,4	10,5	7,3	195	120
440.11/16RFID	11/16	37,0	25,3	6,5	10,9	7,6	202	135

⊞	A ["]	B [mm]	B1 [mm]	E [mm]	E1 [mm]	E2 [mm]	L [mm]	ΔΔ [g]
440.3/4RFID	3/4	41,2	27,8	7,2	11,9	8,3	216	180
440.13/16RFID	13/16	43,1	29,5	6,3	12,3	8,6	224	195
440.7/8RFID	7/8	46,9	32,3	8,3	13,3	9,0	248	240
440.15/16RFID	15/16	51,0	35,0	8,9	14,2	9,7	267	300
440.1PRFID	1	53,0	36,4	9,4	14,7	9,9	274	325
440.1P1/16RFID	1 1/16	58,0	39,2	8,9	15,6	10,4	295	385
440.1P1/8RFID	1 1/8	60,7	40,6	10,6	16,1	10,7	305	425
440.1P1/4RFID	1 1/4	68,0	46,1	11,5	18,0	12,5	355	650

39 - Metric short-reach combination wrenches - RFID

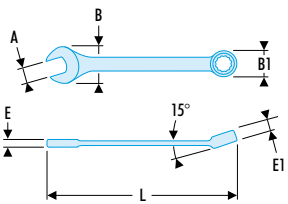

NF ISO 691, NF ISO 7738, NF ISO 3318, NF ISO 1711-1, E74-306, ISO 691, ISO 7738, ISO 3318, ISO 1711-1, DIN ISO 691, DIN ISO 1711-1, ASME B107.100

- Tool with built-in RFID chip for workshop traceability.
- Chip integration by Facom guarantees maximum detection and strength, while preserving the tool's ergonomics.
- Radio frequency identification requires appropriate storage equipment.
- Short combination wrenches: the short handle and compact head allow for ease of access. Ideal for confined access.
- OGV® profile with 12-point ring for powerful tightening while protecting the nut. H suffix = 6-point ring.
- Ring head angled at 15°.
- Open end head angled at 15°.
- Metric sizes: 3.2 to 17 mm.
- Presentation: satin chrome finish.

⊞	A [mm]	B x B1 [mm]	E [mm]	E1 [mm]	⊙ [mm]	L [mm]	ΔΔ [g]
39.5HRFID	5	11,8 x 9,0	3,5	4,0	6	82	15
39.5.5HRFID	5,5	11,8 x 9,5	3,5	4,0	6	84	15
39.6RFID	6	15,0 x 10,4	4,1	5,0	12	90	20
39.7RFID	7	15,0 x 11,5	4,1	5,0	12	90	25
39.8RFID	8	17,2 x 12,5	4,5	5,8	12	94	25
39.9RFID	9	19,4 x 14,0	4,8	6,0	12	98	30
39.10RFID	10	21,5 x 15,3	5,1	6,4	12	103	35

⊞	A [mm]	B x B1 [mm]	E [mm]	E1 [mm]	⊙ [mm]	L [mm]	ΔΔ [g]
39.11RFID	11	23,7 x 16,8	5,3	6,8	12	109	40
39.12RFID	12	26,0 x 18,0	5,5	7,5	12	127	55
39.13RFID	13	28,0 x 19,5	5,8	8,0	12	141	60
39.14RFID	14	30,2 x 20,8	6,0	8,5	12	147	75
39.15RFID	15	32,3 x 22,1	6,4	9,0	12	152	85
39.16RFID	16	34,4 x 23,6	6,7	9,6	12	158	95
39.17RFID	17	36,5 x 25,0	6,9	10,0	12	165	105

Standard ratchet combination wrenches

Standard ratchet combination wrenches

467 - Metric standard ratchet combination wrenches - RFID

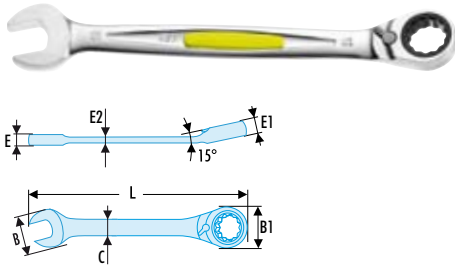

NF ISO 1711-1, NF ISO 691, ISO 1711-1, ISO 691, DIN ISO 1711-1, DIN ISO 691

- Tool with built-in RFID chip for workshop traceability.
- Chip integration by Facom guarantees maximum detection and strength, while preserving the tool's ergonomics.
- Radio frequency identification requires appropriate storage equipment.
- Standard ratchet combination wrenches: for all current applications.
- Compact ratchet mechanism and reversible by lever.
- Increment 5° (7.5° for dimension 6 mm; 6° for dimensions 7, 8 and 9 mm).
- Ring head angled at 15°.
- Open end head angled at 15°.
- Metric sizes: 6 to 32 mm.
- Presentation: satin chrome finish.

RFID	A [mm]	B [mm]	B1 [mm]	C [mm]	E [mm]	E1 [mm]	E2 [mm]	L [mm]	ΔΔ [g]
467.6RFID	6	15,0	14,0	9,7	4,0	6,9	4,5	128	35
467.7RFID	7	16,7	17,0	9,7	4,3	6,5	4,5	140	35
467.8RFID	8	16,7	17,0	9,7	4,3	6,5	4,5	140	35
467.9RFID	9	18,7	18,6	10,3	4,5	6,9	4,5	149	45
467.10RFID	10	20,8	20,2	11,3	5,0	7,3	4,9	158	55
467.11RFID	11	23,0	22,0	12,2	5,3	7,7	5,2	165	65
467.12RFID	12	24,6	23,4	13,0	5,5	8,2	8	171	75
467.13RFID	13	26,8	25,5	14,5	6,1	8,6	8	178	95
467.14RFID	14	29,0	26,9	15,1	6,5	9,0	8,5	190	115
467.15RFID	15	31,0	28,3	16,1	6,8	9,4	9	199	135

RFID	A [mm]	B [mm]	B1 [mm]	C [mm]	E [mm]	E1 [mm]	E2 [mm]	L [mm]	ΔΔ [g]
467.16RFID	16	33,0	29,8	17,3	7,1	9,9	10	208	150
467.17RFID	17	35,5	31,8	18,2	7,5	10,3	11	225	180
467.18RFID	18	37,5	32,7	19,6	8,1	10,7	11,1	236	210
467.19RFID	19	39,4	34,0	20,4	8,6	11,2	11,1	247	240
467.21RFID	21	45,8	40,1	23,9	9,0	13,0	12	287,8	350
467.22RFID	22	45,8	40,1	23,9	9,0	13,0	12	287,8	350
467.24RFID	24	51,8	46,5	26,4	10,0	14,5	12,5	321	490
467.27RFID	27	56,4	52,4	29,2	10,8	15,5	13	356,6	670
467.30RFID	30	62,7	58,1	31,7	11,5	17,0	13,5	400,7	880
467.32RFID	32	66,4	61,9	33,7	12,4	17,5	14	423,5	1090

467 - Inch standard ratchet combination wrenches - RFID

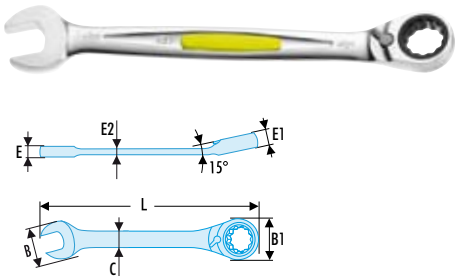

ASME B107.100

- Tool with built-in RFID chip for workshop traceability.
- Chip integration by Facom guarantees maximum detection and strength, while preserving the tool's ergonomics.
- Radio frequency identification requires appropriate storage equipment.
- Standard ratchet combination wrenches: for all current applications.
- Compact ratchet mechanism and reversible by lever.
- Increment 5° (7.5° for dimension 1/4"; 6° for dimensions 5/16" and 11/32").
- Ring head angled at 15°.
- Open end head angled at 15°.
- Dimensions in inches: from 1/4" to 15/16".
- Presentation: satin chrome finish.

RFID	A [mm]	B [mm]	B1 [mm]	C [mm]	E [mm]	E1 [mm]	E2 [mm]	L [mm]	ΔΔ [g]
467.1/4RFID	1/4	15,0	14,0	9,7	4,0	6,9	4,5	128	35
467.5/16RFID	5/16	16,7	17,0	9,7	4,3	6,5	4,5	140	35
467.11/32RFID	11/32	18,7	18,6	10,3	4,5	6,9	4,5	149	45
467.3/8RFID	3/8	20,8	20,2	11,3	5,0	7,3	4,9	158	55
467.7/16RFID	7/16	23,0	22,0	12,2	5,3	7,7	5,2	165	65
467.1/2RFID	1/2	26,8	25,5	14,5	6,1	8,6	8	178	95

RFID	A [mm]	B [mm]	B1 [mm]	C [mm]	E [mm]	E1 [mm]	E2 [mm]	L [mm]	ΔΔ [g]
467.9/16RFID	9/16	29,0	26,9	15,1	6,5	9,0	8,5	190	115
467.5/8RFID	5/8	33,0	29,8	17,3	7,1	9,9	10	208	150
467.11/16RFID	11/16	35,5	31,8	18,2	7,5	10,3	11,1	225	180
467.3/4RFID	3/4	39,4	34,0	20,4	8,6	11,2	11,1	247	240
467.7/8RFID	7/8	45,8	40,1	23,9	9,0	13,0	12	287,8	350
467.15/16RFID	15/16	51,8	46,5	26,4	10,0	14,5	12,5	321	490

Standard ratchet combination wrenches

Fixed and variable opening wrenches

Hinged ratchet combination wrench series

467F - Metric hinged jointed combination wrenches - RFID

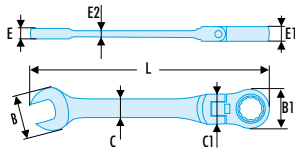

NF ISO 1711-1, NF ISO 691, ISO 1711-1, ISO 691, DIN ISO 1711-1, DIN ISO 691

- Tool with built-in RFID chip for workshop traceability.
- Chip integration by Facom guarantees maximum detection and strength, while preserving the tool's ergonomics.
- Radio frequency identification requires appropriate storage equipment.
- Straight ratchet ring wrenches: to reach the nut flat.
- Compact ratchet mechanism and reversible by flipping the wrench.
- Increment 5° (7.5° for dimension 6 mm; 6° for dimensions 7, 8 and 9 mm).
- Metric sizes: 8 to 19 mm.
- Presentation: satin chrome finish.

➤	A [mm]	B [mm]	B1 [mm]	C [mm]	E [mm]	E1 [mm]	E2 [mm]	L [mm]	ΔΔ [g]
467F.8RFID	8	16,2	16,7	9,0	4,3	6,5	4,5	127,5	50
467F.9RFID	9	18,2	18,6	10,0	4,6	6,9	4,5	132,0	55
467F.10RFID	10	20,3	20,1	10,8	5,0	7,3	4,9	136,5	65
467F.11RFID	11	22,5	21,8	11,8	5,4	7,7	5,2	141,5	70
467F.12RFID	12	24,8	23,0	12,8	5,8	8,2	8	148,0	85
467F.13RFID	13	26,8	25,2	13,6	6,1	8,6	8	155,0	100
467F.14RFID	14	28,7	26,8	14,2	6,4	9,0	8,5	161,0	115
467F.15RFID	15	30,5	28,3	15,4	6,9	9,4	9	170,0	135
467F.16RFID	16	32,9	29,8	16,0	7,2	9,9	10	180,0	160
467F.17RFID	17	34,5	31,8	16,9	7,6	10,3	11	191,0	180
467F.18RFID	18	37,0	32,8	18,0	8,0	10,7	11,1	204,0	210
467F.19RFID	19	39,2	33,9	19,5	8,6	11,2	11,1	216,0	240

467F - Inch hinged jointed combination wrenches - RFID

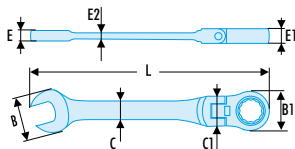

ASME B107.100

- Tool with built-in RFID chip for workshop traceability.
- Chip integration by Facom guarantees maximum detection and strength, while preserving the tool's ergonomics.
- Radio frequency identification requires appropriate storage equipment.
- Hinged head ratchet combination wrenches: to reach difficult access nuts.
- Compact ratchet mechanism and reversible by flipping the wrench.
- Increment 5° (6° for dimensions 8 and 9 mm).
- Ring head hinged at 180°.
- Open end head angled at 15°.
- Dimensions in inches: from 5/16 to 3/4".
- Presentation: satin chrome finish.

➤	A ["]	B [mm]	B1 [mm]	C [mm]	E [mm]	E1 [mm]	E2 [mm]	L [mm]	ΔΔ [g]
467F.5/16RFID	5/16	16,2	16,7	9,0	4,3	6,5	4,5	127,5	50
467F.3/8RFID	3/8	20,3	20,1	10,8	5,0	7,3	4,9	136,5	65
467F.7/16RFID	7/16	22,5	21,8	11,8	5,4	7,7	5,2	141,5	70
467F.1/2RFID	1/2	26,8	25,2	13,6	6,1	8,6	8	155,0	100
467F.9/16RFID	9/16	28,7	26,8	14,2	6,4	9,0	8,5	161,0	115
467F.5/8RFID	5/8	32,9	29,8	16,0	7,2	9,9	10	180,0	165
467F.11/16RFID	11/16	34,5	31,8	16,9	7,6	10,3	11,1	191,0	180
467F.3/4RFID	3/4	39,2	33,9	19,5	8,6	11,2	11,1	216,0	240



Ratchet wrenches

Ratchet ring wrenches

64 - Metric straight ratchet ring wrenches - RFID

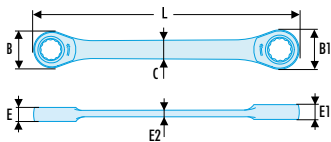

NF ISO 1711-1, NF ISO 691, ISO 1711-1, ISO 691, DIN ISO 1711-1, DIN ISO 691, ASME B107.100

- Tool with built-in RFID chip for workshop traceability.
- Chip integration by Facom guarantees maximum detection and strength, while preserving the tool's ergonomics.
- Radio frequency identification requires appropriate storage equipment.
- Straight ratchet ring wrenches: to reach the nut flat.
- Compact ratchet mechanism and reversible by flipping the wrench.
- Increment 5° (7.5° for dimension 6 mm; 6° for dimensions 7, 8 and 9 mm).
- Metric sizes: 6 to 24 mm.
- Presentation: satin chrome finish.

⇒	A [mm]	B [mm]	B1 [mm]	C [mm]	E [mm]	E1 [mm]	E2 [mm]	L [mm]	ΔΔ [g]
64.6X7RFID	6x7	14,2	17,2	8,0	6,3	6,5	5	115	40
64.8X9RFID	8x9	16,8	20,2	8,3	6,5	6,9	5,2	128	50
64.10X11RFID	10x11	20,2	21,8	9,1	7,3	7,7	9	150	70
64.12X13RFID	12x13	23	24,8	11,3	8,2	8,6	9,5	170	90
64.14X15RFID	14x15	26,5	29,5	13,1	9,0	9,4	12	190	140
64.16X18RFID	16x18	29,5	33,5	14,8	9,9	10,7	12,5	210	195
64.17X19RFID	17x19	31,5	33,5	15,2	10,3	11,2	12,5	230	205
64.21X23RFID	21x23	40	46,0	15,2	13,0	14,5	16	260	490
64.22X24RFID	22x24	40	46,0	15,2	13,0	14,5	16	260	490



64 - Inch straight ratchet ring wrenches - RFID

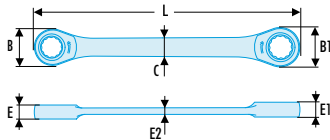

ASME B107.100

- Tool with built-in RFID chip for workshop traceability.
- Chip integration by Facom guarantees maximum detection and strength, while preserving the tool's ergonomics.
- Radio frequency identification requires appropriate storage equipment.
- Straight ratchet ring wrenches: to reach the nut flat.
- Compact ratchet mechanism and reversible by flipping the wrench.
- Increment 5° (7.5° for dimension 1/4" mm; 6° for dimensions 5/16" and 11/32").
- Dimensions in inches: from 1/4" to 5/16".
- Presentation: satin chrome finish.

⇒	A ["]	B [mm]	B1 [mm]	C [mm]	E [mm]	E1 [mm]	E2 [mm]	L [mm]	ΔΔ [g]
64.1/4X5/16RFID	1/4x5/16	14,2	17,2	8,0	6,3	6,5	5	115	40
64.5/16X11/32RFID	5/16x11/32	16,8	20,2	8,3	6,5	6,9	5,2	128	50
64.3/8X7/16RFID	3/8x7/16	20,2	21,8	9,1	7,3	7,7	9	150	70
64.1/2X9/16RFID	1/2x9/16	23	24,8	11,3	8,6	9,0	9,5	180	125
64.5/8X11/16RFID	5/8x11/16	29,5	33,5	14,8	9,9	10,7	12,5	210	195
64.3/4X13/16RFID	3/4x13/16	33,5	40,0	15,2	11,2	13,0	12,5	245	320
64.7/8X15/16RFID	7/8x15/16	44	46,0	15,2	13,0	14,5	16	260	490



Ratchet wrenches

Fixed and variable opening wrenches

15° hinged ratchet ring wrenches

65 - Metric 15° hinged ratchet ring wrenches - RFID

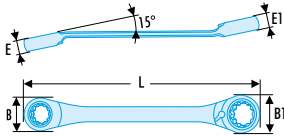

NF ISO 1711-1, NF ISO 691, ISO 1711-1, ISO 691, DIN ISO 1711-1, DIN ISO 691, ASME B107.100

- Tool with built-in RFID chip for workshop traceability.
- Chip integration by Facom guarantees maximum detection and strength, while preserving the tool's ergonomics.
- Radio frequency identification requires appropriate storage equipment.
- Straight ratchet ring wrenches: to reach the nut flat.
- Compact ratchet mechanism and reversible by flipping the wrench.
- Increment 5° (7.5° for dimension 6 mm; 6° for dimensions 7, 8 and 9 mm).
- Metric sizes: 6 to 24 mm.
- Presentation: satin chrome finish.

65	A [mm]	B [mm]	B1 [mm]	E [mm]	E1 [mm]	L [mm]	ΔΔ [g]
65.6X7RFID	6x7	14,0	17,0	6,3	6,5	115	35
65.8X9RFID	8x9	17,0	20,2	6,5	6,9	128	50
65.10X11RFID	10x11	20,2	22,0	7,3	7,7	150	75
65.12X13RFID	12x13	23,4	25,5	8,2	8,6	170	100
65.14X15RFID	14x15	26,9	29,8	9,0	9,4	190	140
65.16X18RFID	16x18	29,8	34,0	9,9	10,7	210	200
65.17X19RFID	17x19	31,8	34,0	10,3	11,2	230	220
65.21X23RFID	21x23	40,1	46,0	13,0	14,5	260	400
65.22X24RFID	22x24	40,1	46,5	13,0	14,5	260	435

65 - Inch 15° hinged ratchet ring wrenches - RFID

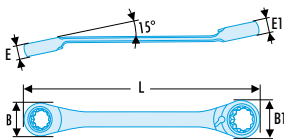

ASME B107.100

- Tool with built-in RFID chip for workshop traceability.
- Chip integration by Facom guarantees maximum detection and strength, while preserving the tool's ergonomics.
- Radio frequency identification requires appropriate storage equipment.
- 15° hinged ratchet ring wrenches: ring offset to clear fingers or obstacles.
- Compact ratchet mechanism and reversible by lever.
- Increment 5° (7.5° for dimension 1/4"; 6° for dimensions 5/16" and 11/32").
- Ring head angled at 15°.
- Dimensions in inches: from 1/4" to 15/16".
- Presentation: satin chrome finish.

65	A ["]	B [mm]	B1 [mm]	E [mm]	E1 [mm]	L [mm]	ΔΔ [g]
65.1/4X5/16RFID	1/4x5/16	14,0	17,0	6,3	6,5	115	35
65.5/16X11/32RFID	5/16x11/32	17,0	20,2	6,5	6,9	128	50
65.3/8X7/16RFID	3/8x7/16	20,2	22,0	7,3	7,7	150	75
65.1/2X9/16RFID	1/2x9/16	25,5	26,9	8,6	9,0	180	120
65.5/8X11/16RFID	5/8x11/16	29,8	31,8	9,9	10,3	200	180
65.3/4X13/16RFID	3/4x13/16	34,0	40,1	11,2	13,0	245	300
65.7/8X15/16RFID	7/8x15/16	40,1	46,5	13,0	14,5	260	430

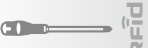

Open end wrenches

Open end wrenches

44 - Metric open end wrenches - RFID

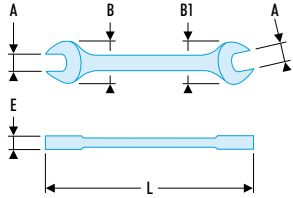

NF ISO 10102, NF ISO 3318, NF ISO 1711-1, NF ISO 691, ISO 10102, ISO 3318, ISO 1711-1, ISO 691, DIN ISO 1711-1, DIN ISO 691, DIN 3110

- Tool with built-in RFID chip for workshop traceability.
- Chip integration by Facom guarantees maximum detection and strength, while preserving the tool's ergonomics.
- Radio frequency identification requires appropriate storage equipment.
- Open end wrenches = the open ends are slimmer than a standard combination wrench for better accessibility. Examples: brake calipers, hydraulic hose locknuts.
- Heads hinged at 15°.
- Metric sizes: 6 to 32 mm.
- Presentation: satin chrome finish.

➤	A [mm]	B x B1 [mm]	E [mm]	L [mm]	ΔΔ [g]
44.6X7RFID	6x7	15,0 x 17,5	3,5	120	25
44.8X9RFID	8x9	18,5 x 21,0	3,8	137	35
44.8X10RFID	8x10	19,0 x 23,0	4,2	143	45
44.10X11RFID	10x11	23,0 x 25,0	4,7	152	55
44.10X13RFID	10x13	23,0 x 29,0	5,1	162	65
44.12X13RFID	12x13	25,5 x 29,0	5,1	167	70
44.14X15RFID	14x15	31,0 x 33,0	5,5	182	95
44.16X17RFID	16x17	35,5 x 37,0	6,3	200	125
44.17X19RFID	17x19	37,0 x 42,0	6,8	210	155
44.18X19RFID	18x19	39,0 x 42,0	7,3	220	170

➤	A [mm]	B x B1 [mm]	E [mm]	L [mm]	ΔΔ [g]
44.20X22RFID	20x22	43,0 x 48,5	7,5	240	210
44.21X23RFID	21x23	47,0 x 50,5	8,3	242	230
44.22X24RFID	22x24	47,5 x 52,0	8,8	261	270
44.24X27RFID	24x27	51,0 x 58,0	8,8	270	335
44.25X28RFID	25x28	56,0 x 61,6	8,8	282	370
44.26X28RFID	26x28	56,0 x 61,6	8,8	282	370
44.27X29RFID	27x29	59,0 x 64,0	9,5	301	460
44.27X30RFID	27x30	59,0 x 64,0	9,5	301	460
44.30X32RFID	30x32	63,0 x 70,0	9,8	318	525

44 - Metric open end wrenches - RFID

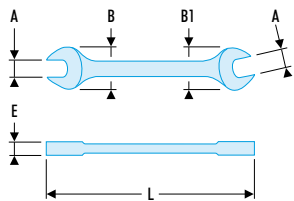

- Tool with built-in RFID chip for workshop traceability.
- Chip integration by Facom guarantees maximum detection and strength, while preserving the tool's ergonomics.
- Radio frequency identification requires appropriate storage equipment.
- Open end wrenches = the open ends are slimmer than a standard combination wrench for better accessibility. Examples: brake calipers, hydraulic hose locknuts.
- Heads hinged at 15°.
- Dimensions in inches: from 1/4" to 1 1/4".
- Presentation: satin chrome finish.

➤	A ["]	B x B1 [mm]	E [mm]	L [mm]	ΔΔ [g]
44.1/4X5/16RFID	1/4x5/16	15,0 x 17,5	3,5	120	25
44.11/32X13/32RFID	11/32x13/32	19,0 x 23,0	4,2	143	45
44.3/8X7/16RFID	3/8x7/16	23,0 x 25,0	4,7	152	55
44.1/2X9/16RFID	1/2x9/16	29,0 x 33,5	5,5	177	85
44.5/8X11/16RFID	5/8x11/16	37,0 x 42,0	6,8	210	155

➤	A ["]	B x B1 [mm]	E [mm]	L [mm]	ΔΔ [g]
44.11/16X3/4RFID	11/16x3/4	37,0 x 42,0	6,8	210	155
44.3/4X13/16RFID	3/4x13/16	43,0 x 48,5	7,5	240	210
44.7/8X15/16RFID	7/8x15/16	47,5 x 52,0	8,3	251	270
44.1PX1P1/16RFID	1"x1 1/16	56,0 x 61,6	8,8	282	370
44.1P1/8X1 1/4RFID	1 1/8x1 1/4	63,0 x 70,0	9,8	318	525

Angled open-socket wrenches

Fixed and variable opening wrenches

Angled open-socket wrenches

76 - Forged metric 12 x 6 point angled open-socket wrenches - RFID

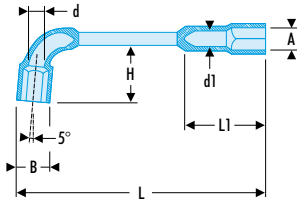

NF ISO 2236, NF ISO 691, ISO 2236, ISO 691, DIN ISO 691

- Tool with built-in RFID chip for workshop traceability.
- Chip integration by Facom guarantees maximum detection and strength, while preserving the tool's ergonomics.
- Radio frequency identification requires appropriate storage equipment.
- Angled socket wrenches: wrenches designed for powerful unlocking.
- 12-point short head for 30° increment and 6-point long head.
- Opening of the short head for passing threaded rods.
- Metric sizes: 6 to 16 mm.
- Presentation: satin chrome finish.

76	A [mm]	B [mm]	d [mm]	d1 [mm]	H [mm]	L [mm]	L1 [mm]	ΔΔ [g]
76.6RFID	6	10,0	4,5	4,5	16	102	21	60
76.7RFID	7	11,0	4,5	4,5	17	106	22	65
76.8RFID	8	12,5	7,0	6,0	19	114	25	90
76.9RFID	9	13,5	7,0	6,0	20	122	26	95
76.10RFID	10	15,0	8,0	7,0	24	129	28	125
76.11RFID	11	16,5	8,0	7,0	25	136	30	145

76	A [mm]	B [mm]	d [mm]	d1 [mm]	H [mm]	L [mm]	L1 [mm]	ΔΔ [g]
76.12RFID	12	18,0	9,0	8,0	28	144	36	185
76.13RFID	13	19,5	9,0	8,0	30	152	38	205
76.14RFID	14	21,0	10,5	9,0	32	160	40	235
76.15RFID	15	22,5	10,5	10,0	34	169	42	260
76.16RFID	16	24,0	13,0	12,0	37	178	46	315

75 - Forged metric 6 x 6 point angled open-socket wrenches - RFID

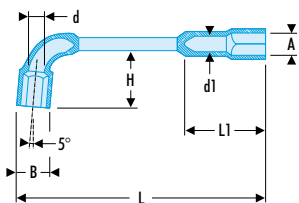

NF ISO 2236, NF ISO 691, ISO 2236, ISO 691, DIN ISO 691

- Tool with built-in RFID chip for workshop traceability.
- Chip integration by Facom guarantees maximum detection and strength, while preserving the tool's ergonomics.
- Radio frequency identification requires appropriate storage equipment.
- Angled socket wrenches: wrenches designed for powerful unlocking.
- Short head and long head: 6-point.
- Opening of the short head for passing threaded rods.
- Metric sizes: 17 to 32 mm.
- Presentation: satin chrome finish.

75	A [mm]	B [mm]	d [mm]	d1 [mm]	H [mm]	L [mm]	L1 [mm]	ΔΔ [g]
75.17RFID	17	25,5	13,0	12,0	39	187	48	345
75.18RFID	18	26,5	13,0	12,0	40	195	50	395
75.19RFID	19	28,5	15,0	12,0	41	204	51	460
75.21RFID	21	30,5	15,0	14,0	46	221	55	520
75.22RFID	22	32,0	15,0	14,0	48	230	57	565

75	A [mm]	B [mm]	d [mm]	d1 [mm]	H [mm]	L [mm]	L1 [mm]	ΔΔ [g]
75.24RFID	24	34,5	18,0	16,0	54	250	67	690
75.27RFID	27	38,0	22,0	19,0	58	280	73	980
75.30RFID	30	42,0	24,0	21,0	64	310	83	1330
75.32RFID	32	44,5	24,0	22,6	74	330	88	1430



Nut drivers and adjustable wrenches

NUT DRIVERS

Nut drivers

- Forged body for maximum strength.
- Hollow body allows insertion over long threaded rods.

PROTWIST® handle

- Natural grip and excellent ergonomics.
- Fast and effective approach.
- Comfortable force tightening.
- High torque application with lesser effort.
- Resistance to loads, impacts, abrasion and chemicals.



74A - Forged nut driver - metric - RFID

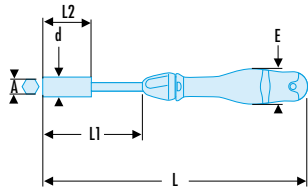

NF ISO 2236, NF ISO 691, ISO 2236, ISO 691, DIN 3125, DIN ISO 691

- Tool with built-in RFID chip for workshop traceability.
- Chip integration by Facom guarantees maximum detection and strength, while preserving the tool's ergonomics.
- Radio frequency identification requires appropriate storage equipment.
- Ideal for screws with limited access in height or precision mechanics.
- Protwist screwdriver handle for optimum comfort and for powerful unlocking.
- 6-point socket with deep opening for long threads.
- Forged body for maximum strength.
- Metric sizes: 3.2 to 14 mm.
- Presentation: satin chrome finish.

RFID	A [mm]	d [mm]	E [mm]	L [mm]	L1 [mm]	L2 [mm]	ΔΔ [g]
74A.3.2FRFID	3,2	6,0	36	245	106	20	140
74A.4FRFID	4,0	7,0	36	245	106	20	145
74A.4.5FRFID	4,5	7,5	36	245	106	25	150
74A.5FRFID	5,0	8,0	36	245	106	25	150
74A.5.5FRFID	5,5	8,0	36	245	106	30	150
74A.6FRFID	6,0	9,5	36	245	106	35	155
74A.7FRFID	7,0	9,5	36	245	106	35	160

RFID	A [mm]	d [mm]	E [mm]	L [mm]	L1 [mm]	L2 [mm]	ΔΔ [g]
74A.8FRFID	8,0	12,0	36	245	106	50	185
74A.9FRFID	9,0	12,0	36	245	106	50	190
74A.10FRFID	10,0	14,5	40	250	106	50	230
74A.11FRFID	11,0	16,0	40	250	106	50	250
74A.12FRFID	12,0	17,0	40	250	106	50	250
74A.13FRFID	13,0	18,5	40	250	106	55	290
74A.14FRFID	14,0	20,0	40	250	106	55	295

113A.C - Chromed adjustable wrenches - RFID

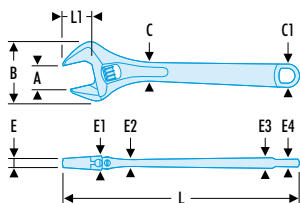

NF ISO 6787, ISO 6787, DIN 3117, ASME B107.100

- Tool with built-in RFID chip for workshop traceability.
- Chip integration by Facom guarantees maximum detection and strength, while preserving the tool's ergonomics.
- Radio frequency identification requires appropriate storage equipment.
- Easy to access button for setting jaws.
- Non-protruding moving jaw at maximum capacity.
- Pre-adjustment of jaw opening thanks to millimetric gradation.
- Right-hand button rotation.
- Range from 6" to 18".
- Presentation: chromed body and polished head faces.

RFID	A [mm]	B [mm]	C x C1 [mm]	E [mm]	E1 [mm]	E2 [mm]	E3 [mm]	E4 [mm]	L [mm]	L1 [mm]	ΔΔ [g]
113A.6CRFID	20	45,0	14,8 x 18,5	5	11,8	6,0	8,3	5,8	155	19	155
113A.8CRFID	27	61,5	18,5 x 24,0	6,5	13,5	9,0	11,0	8,5	206	24	305
113A.10CRFID	30	69,5	21,5 x 28,5	9	15,5	9,5	12,7	10,0	255	29	510
113A.12CRFID	34	80,0	25,0 x 31,0	10	18,0	10,2	13,0	10,0	306	34	730
113A.15CRFID	44	97,0	28,0 x 35,0	13,5	20,0	12,0	14,8	11,5	380	44	1175
113A.18CRFID	53	115,0	31,0 x 38,5	16	22,5	14,3	17,8	13,5	456	53	1820

Radio 1/4" range

Ratchets - Sockets

1/4" ratchets

1/4" maintenance free pear head ratchet - RFID

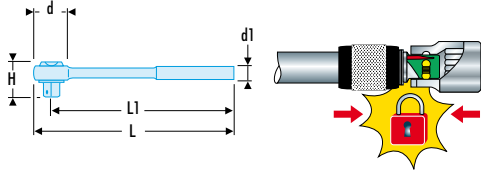

RFID

NF ISO 3315, ISO 3315, DIN 3122, ASME B107.10

- Tool with built-in RFID chip for workshop traceability.
- Chip integration by Facom guarantees maximum detection and strength, while preserving the tool's ergonomics.
- Radio frequency identification requires appropriate storage equipment.
- Dust proof, maintenance free mechanism.
- 72 teeth mechanism for 5° increments.
- Drive direction switch allows easy reversal even with gloved or greasy hands.
- Palm control system - allows the operator to press down on the head avoiding risk of accidental reverse.
- Ultra-compact head.
- Hook for hanging when working at height.
- Ergonomic comfort grip handle design resistant to workshop chemicals and solvents.

RFID	d [mm]	d1 [mm]	H [mm]	L [mm]	L1 [mm]	ΔΔ [g]
RL.171RFID	22	20	25	120	110	90

1/4" fast action twist handle ratchet - RFID

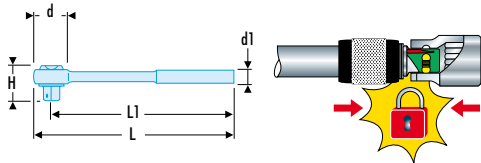

RFID

NF ISO 3315, ISO 3315, DIN 3122, ASME B107.10

- Tool with built-in RFID chip for workshop traceability.
- Chip integration by Facom guarantees maximum detection and strength, while preserving the tool's ergonomics.
- Radio frequency identification requires appropriate storage equipment.
- Twist handle for working twice as fast in confined spaces
- 6° increments for final tightening.
- Socket safety locking: no more lost sockets.
- Palm control system - allows the operator to press down on the head avoiding risk of accidental reverse.

RFID	d [mm]	d1 [mm]	H [mm]	L [mm]	L1 [mm]	ΔΔ [g]
R.360RFID	27	21	29	120	120	160

R.236AFRFID PROTWIST® fluorescent handle screwdriver 1/4" - 158 mm - RFID



RFID

NF ISO 3315, ISO 3315, DIN 3122, ASME B107.10

- Tool with built-in RFID chip for workshop traceability.
- Chip integration by Facom guarantees maximum detection and strength, while preserving the tool's ergonomics.
- Radio frequency identification requires appropriate storage equipment.
- Detectable by its fluorescence, activated by a lamp or UV neon light.
- Bi-material grip resists to impacts, abrasion, and chemicals.
- Finish: chromed.

65.PERFID Bit-holder ratchet wrench 1/4" - 5/16" RFID



RFID

- Tool with built-in RFID chip for workshop traceability.
- Chip integration by Facom guarantees maximum detection and strength, while preserving the tool's ergonomics.
- Radio frequency identification requires appropriate storage equipment.
- Takes the following bits: - Series 1: hexagon 1/4".
- Series 2: hexagon 5/16".
- Used for installing 1/4" and 5/16" aircraft fasteners.
- Increment: 5°. - Heads angled at 15°. - Bits held by a spring clip.
- Knurled head for fast pre-tightening.
- Length 150 mm.
- Satin chrome finish.
- Weight: 74 g.



RFID



RFID

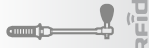

RFID



RFID



RFID



RFID



FLUO



FLUO



FLUO



FLUO



FLUO

Radio 1/4" range

■ R - 1/4" drive extension - RFID

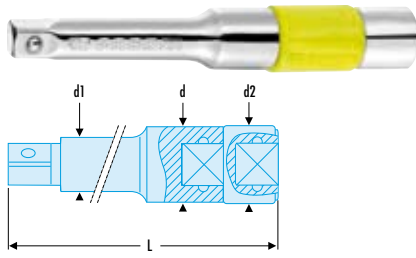

- Tool with built-in RFID chip for workshop traceability.
- Chip integration by Facom guarantees maximum detection and strength, while preserving the tool's ergonomics.
- Radio frequency identification requires appropriate storage equipment.
- Finish: chromed.

RFID	L [mm]	d [mm]	d1 [mm]	d2 [mm]	ΔΔ [g]
R.209RFID	85	12	8,2	13	50

■ R.RC - 1/4" drive locking extensions - RFID

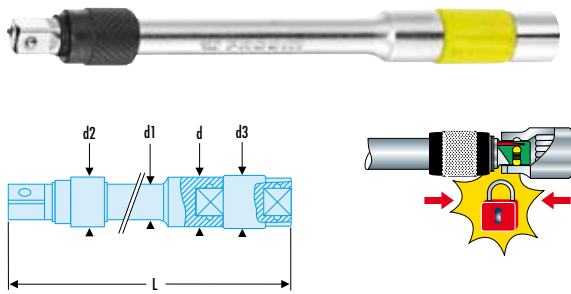

- Tool with built-in RFID chip for workshop traceability.
- Chip integration by Facom guarantees maximum detection and strength, while preserving the tool's ergonomics.
- Radio frequency identification requires appropriate storage equipment.
- Locking mechanism.
- Finish: bright chrome.

RFID	L [mm]	d [mm]	d1 [mm]	d2 [mm]	d3 [mm]	ΔΔ [g]
R.210RCRFID	130	8,2	12	13	13	65
R.215RCRFID	180	8,2	12	13	13	80
R.217RCRFID	280	8,2	12	13	13	120

■ 1/4" universal joint - RFID

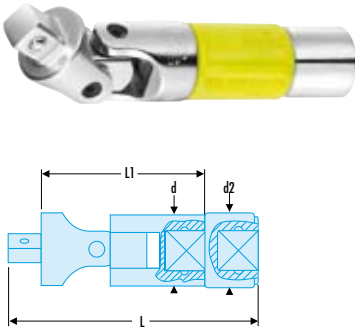

- Tool with built-in RFID chip for workshop traceability.
- Chip integration by Facom guarantees maximum detection and strength, while preserving the tool's ergonomics.
- Radio frequency identification requires appropriate storage equipment.
- Spring-stiffened joints. Stays in position when reaching for fasteners.
- Finish: bright chrome.

RFID	d [mm]	d2 [mm]	L [mm]	L1 [mm]	ΔΔ [g]
R.240ARFID	13	13	63	25	40

■ 1/4" to 3/8" coupler - RFID

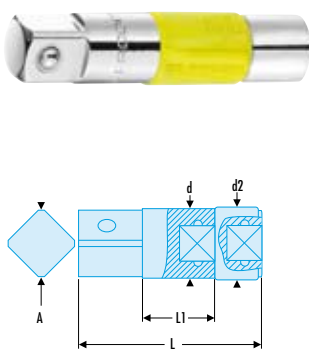

- Tool with built-in RFID chip for workshop traceability.
- Chip integration by Facom guarantees maximum detection and strength, while preserving the tool's ergonomics.
- Radio frequency identification requires appropriate storage equipment.
- 1/4" female to 3/8" male square drive.
- For adapting 3/8" drive sockets.
- Finish: bright chrome.

RFID	d [mm]	d1 [mm]	d2 [mm]	L [mm]	L1 [mm]	ΔΔ [g]
R.232RFID	12	12	21	43,5	13,5	50

Radio 1/4" range

Ratchets - Sockets

1/4" sockets

R - 1/4" drive metric 6-point sockets - RFID

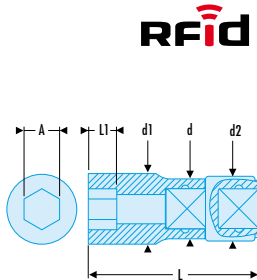

NF ISO 1711-1, ISO 1711-1

- Tool with built-in RFID chip for workshop traceability.
- Chip integration by Facom guarantees maximum detection and strength, while preserving the tool's ergonomics.
- Radio frequency identification requires appropriate storage equipment.
- OGV® profile: more powerful tightening, preserves fasteners.
- Finish: bright chrome.

Socket	A [mm]	⌀ [mm]	d [mm]	d1 [mm]	d2 [mm]	L [mm]	L1 [mm]	ΔΔ [g]
R.3.2RFID	3,2	6	11,2	5,9	13	52	2,4	30
R.4RFID	4,0	6	11,2	6,9	13	52	2,6	30
R.5RFID	5,0	6	11,2	8,2	13	52	4,8	30
R.5.5RFID	5,5	6	11,2	8,8	13	52	4,8	30
R.6RFID	6,0	6	11,2	9,4	13	52	5,6	30
R.7RFID	7,0	6	11,0	11,0	13	52	6,0	30
R.8RFID	8,0	6	12,0	12,0	13	52	6,5	35

Socket	A [mm]	⌀ [mm]	d [mm]	d1 [mm]	d2 [mm]	L [mm]	L1 [mm]	ΔΔ [g]
R.9RFID	9,0	6	13,2	13,2	13	52	6,5	35
R.10RFID	10,0	6	14,7	14,7	13	52	7,8	40
R.11RFID	11,0	6	15,8	15,8	21	41	9,0	50
R.12RFID	12,0	6	17,0	17,0	21	41	9,5	55
R.13RFID	13,0	6	17,7	17,7	21	41	10,0	55
R.14RFID	14,0	6	18,7	18,7	21	41	10,0	60

R - 1/4" drive inch 6-point sockets - RFID

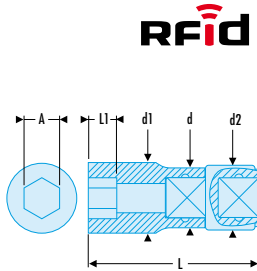

- Tool with built-in RFID chip for workshop traceability.
- Chip integration by Facom guarantees maximum detection and strength, while preserving the tool's ergonomics.
- Radio frequency identification requires appropriate storage equipment.
- OGV® profile: more powerful tightening, preserves fasteners.
- Finish: bright chrome.
- Available as rack set (Ref R.40U).

Socket	A ["]	⌀ [mm]	d [mm]	d1 [mm]	d2 [mm]	L [mm]	L1 [mm]	ΔΔ [g]
R.3/16RFID	3/16	6	11,2	8,0	13	52	4,8	30
R.7/32RFID	7/32	6	11,2	9,0	13	52	5,5	30
R.1/4RFID	1/4	6	11,2	10,1	13	52	6,0	30
R.9/32RFID	9/32	6	11,0	11,0	13	52	6,0	30
R.5/16RFID	5/16	6	12,0	12,0	13	52	6,5	35
R.11/32RFID	11/32	6	13,2	13,2	13	52	6,5	35

Socket	A ["]	⌀ [mm]	d [mm]	d1 [mm]	d2 [mm]	L [mm]	L1 [mm]	ΔΔ [g]
R.3/8RFID	3/8	6	14,7	14,7	13	52	7,8	40
R.13/32RFID	13/32	6	14,7	14,7	13	52	7,8	40
R.7/16RFID	7/16	6	15,8	15,8	21	41	9,0	50
R.1/2RFID	1/2	6	17,7	17,7	21	41	10,0	55
R.9/16RFID	9/16	6	18,7	18,7	21	41	10,0	55

R.E - 1/4" drive metric 12-point sockets - RFID

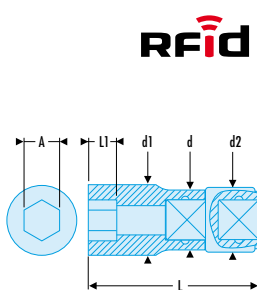

NF ISO 1711-1, ISO 1711-1

- Tool with built-in RFID chip for workshop traceability.
- Chip integration by Facom guarantees maximum detection and strength, while preserving the tool's ergonomics.
- Radio frequency identification requires appropriate storage equipment.
- OGV® profile: more powerful tightening, preserves fasteners.
- Finish: bright chrome.

Socket	A [mm]	⌀ [mm]	d [mm]	d1 [mm]	d2 [mm]	L [mm]	L1 [mm]	ΔΔ [g]
R.5.5ERFID	5,5	12	11,2	8,8	13	52	4,8	30
R.6ERFID	6,0	12	11,2	9,4	13	52	5,6	30
R.7ERFID	7,0	12	11,0	11,0	13	52	6,0	30
R.8ERFID	8,0	12	12,0	12,0	13	52	6,5	35
R.9ERFID	9,0	12	13,2	13,2	13	52	6,5	35

Socket	A [mm]	⌀ [mm]	d [mm]	d1 [mm]	d2 [mm]	L [mm]	L1 [mm]	ΔΔ [g]
R.10ERFID	10,0	12	14,7	14,7	13	52	7,8	40
R.11ERFID	11,0	12	15,8	15,8	21	41	9,0	50
R.12ERFID	12,0	12	17,0	17,0	21	41	9,5	55
R.13ERFID	13,0	12	17,7	17,7	21	41	10,0	55
R.14ERFID	14,0	12	18,7	18,7	21	41	10,0	60

Radio 1/4" range

RB - 1/4" drive inch 12-point thin wall sockets - RFID

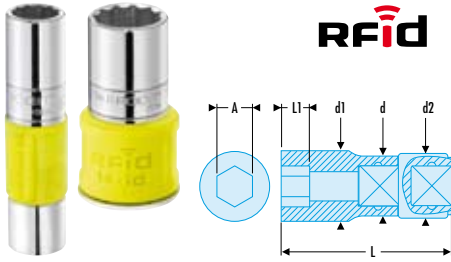

- Tool with built-in RFID chip for workshop traceability.
- Chip integration by Facom guarantees maximum detection and strength, while preserving the tool's ergonomics.
- Radio frequency identification requires appropriate storage equipment.
- OGV® profile: more powerful tightening, preserves fasteners.
- Thin-wall for better access, conform with aeronautical standards.
- Dimensions in inches: from 3/16" to 9/16".
- Finish: bright chrome.

➤	A ["]	⊕ [mm]	d [mm]	d1 [mm]	d2 [mm]	L [mm]	L1 [mm]	ΔΔ [g]
RB.3/16RFID	3/16	12	11,2	7,6	13	52	4,8	30
RB.7/32RFID	7/32	12	11,2	8,7	13	52	5,5	30
RB.1/4RFID	1/4	12	11,2	9,7	13	52	6,0	30
RB.9/32RFID	9/32	12	11,2	10,6	13	52	6,0	35
RB.5/16RFID	5/16	12	11,9	11,9	13	52	6,5	30

➤	A ["]	⊕ [mm]	d [mm]	d1 [mm]	d2 [mm]	L [mm]	L1 [mm]	ΔΔ [g]
RB.11/32RFID	11/32	12	12,9	12,9	13	52	6,5	35
RB.3/8RFID	3/8	12	13,7	13,7	13	52	7,8	35
RB.7/16RFID	7/16	12	14,8	15,8	21	41	9,0	50
RB.1/2RFID	1/2	12	16,0	16,9	21	41	10,0	50
RB.9/16RFID	9/16	12	17,5	18,7	21	41	10,0	55

1/4" long-reach sockets

R.LA - 1/4" long-reach metric 6-point sockets - RFID

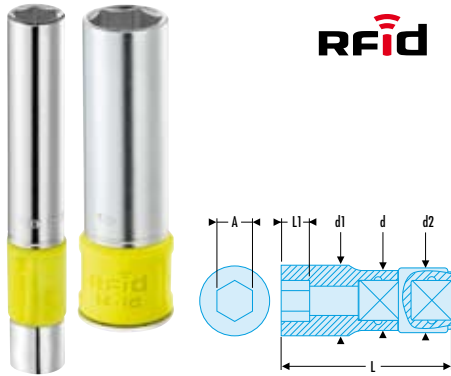

NF ISO 1711-1, ISO 1711-1

- Tool with built-in RFID chip for workshop traceability.
- Chip integration by Facom guarantees maximum detection and strength, while preserving the tool's ergonomics.
- Radio frequency identification requires appropriate storage equipment.
- OGV® profile: more powerful tightening, preserves fasteners.
- Long-reach sockets for long recess or thread access.
- Metric dimensions : from 3,2 to 14 mm.
- Finish: bright chrome.

➤	A [mm]	⊕ [mm]	d [mm]	d1 [mm]	d2 [mm]	L [mm]	L1 [mm]	ΔΔ [g]
R.3.2LARFID	3,2	6	12,0	5,80	13	50,5	1,8	40
R.4LARFID	4	6	12,0	6,80	13	50,5	2,0	40
R.5LARFID	5	6	12,0	8,10	13	50,5	2,3	40
R.5.5LARFID	5,5	6	12,0	8,10	13	50,5	3,0	40
R.6LARFID	6	6	12,0	9,40	13	50,5	5,6	40
R.7LARFID	7	6	12,0	10,90	13	50,5	7,1	50
R.8LARFID	8	6	12,0	12,00	13	50,5	7,9	50

➤	A [mm]	⊕ [mm]	d [mm]	d1 [mm]	d2 [mm]	L [mm]	L1 [mm]	ΔΔ [g]
R.9LARFID	9	6	12,8	12,80	13	50,5	7,9	55
R.10LARFID	10	6	14,3	14,30	13	50,5	7,9	65
R.11LARFID	11	6	16,0	16,00	21	50,5	7,9	85
R.12LARFID	12	6	16,8	16,80	21	50,5	8,4	80
R.13LARFID	13	6	18,2	18,20	21	50,5	8,4	90
R.14LARFID	14	6	19,2	19,20	21	50,5	10,2	100

R.EL - 1/4" long-reach metric 12-point sockets - RFID

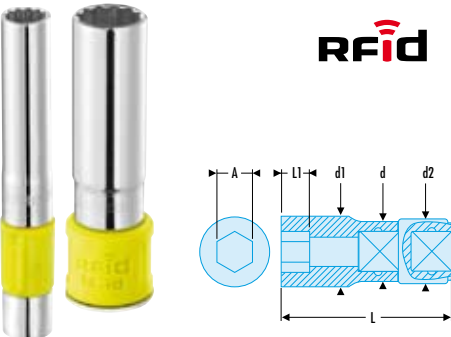

NF ISO 1711-1, ISO 1711-1

- Tool with built-in RFID chip for workshop traceability.
- Chip integration by Facom guarantees maximum detection and strength, while preserving the tool's ergonomics.
- Radio frequency identification requires appropriate storage equipment.
- OGV® profile: more powerful tightening, preserves fasteners.
- Long-reach sockets for long recess or thread access.
- High performance, suitable for aircraft fasteners to AS954E.
- Thinner socket walls for better accessibility.
- Metric dimensions : from 4 to 14 mm.
- Finish: bright chrome.

➤	A [mm]	⊕ [mm]	d [mm]	d1 [mm]	d2 [mm]	L [mm]	L1 [mm]	ΔΔ [g]
R.4ELRFID	4	12	6,7	11,2	13	80	4	40
R.4.5ELRFID	4,5	12	7,3	11,2	13	80	4,5	40
R.5ELRFID	5	12	7,8	11,2	13	80	5,5	40
R.5.5ELRFID	5,5	12	8,5	11,2	13	80	6	40
R.6ELRFID	6	12	9,2	11,2	13	80	7	40
R.7ELRFID	7	12	10,3	11,2	13	80	8	50
R.8ELRFID	8	12	11,2	11,7	13	80	9	50

➤	A [mm]	⊕ [mm]	d [mm]	d1 [mm]	d2 [mm]	L [mm]	L1 [mm]	ΔΔ [g]
R.9ELRFID	9	12	13	12	13	80	10	55
R.10ELRFID	10	12	14,3	12,9	13	80	11	65
R.11ELRFID	11	12	15,5	14,3	21	69	12	85
R.12ELRFID	12	12	16,8	15,5	21	69	13	90
R.13ELRFID	13	12	18	16,4	21	69	14	90
R.14ELRFID	14	12	19,3	17,9	21	69	16	100

Radio 1/4" range

Ratchets - Sockets

R.EL - 1/4" long-reach metric 12-point sockets - RFID

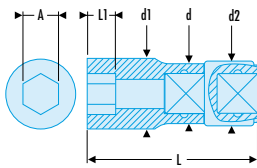

- Tool with built-in RFID chip for workshop traceability.
- Chip integration by Facom guarantees maximum detection and strength, while preserving the tool's ergonomics.
- Radio frequency identification requires appropriate storage equipment.
- OGV® profile: more powerful tightening, preserves fasteners.
- Long-reach sockets for long recess or thread access.
- High performance, suitable for aircraft fasteners to AS954E.
- Thinner socket walls for better accessibility.
- Dimensions in inches: from 3/16" to 9/16".
- Finish: bright chrome.

RFID	A ["]	⚙ [mm]	d [mm]	d1 [mm]	d2 [mm]	L [mm]	L1 [mm]	ΔΔ [g]
R.3/16ELRFID	3/16	12	10,9	7,7	13	80	6,0	35
R.7/32ELRFID	7/32	12	10,9	8,5	13	80	7,4	35
R.1/4ELRFID	1/4	12	10,9	9,4	13	80	7,4	40
R.9/32ELRFID	9/32	12	10,9	10,2	13	80	8,5	40
R.5/16ELRFID	5/16	12	11,8	11,4	13	80	9,0	45
R.11/32ELRFID	11/32	12	12,0	12,5	13	80	9,7	45
R.3/8ELRFID	3/8	12	12,8	13,7	13	80	11,2	55
R.7/16ELRFID	7/16	12	14,3	15,6	21	69	11,9	70
R.1/2ELRFID	1/2	12	16,2	17,3	21	69	13,8	75
R.9/16ELRFID	9/16	12	17,1	18,8	21	69	16,2	80

R.F - 1/4" drive hinged 12-point sockets - RFID

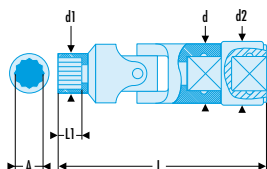

- Tool with built-in RFID chip for workshop traceability.
- Chip integration by Facom guarantees maximum detection and strength, while preserving the tool's ergonomics.
- Radio frequency identification requires appropriate storage equipment.
- OGV® profile: more powerful tightening, preserves fasteners.
- Compact solution used instead of universal joint.
- Dimensions in inches: from 3/16" to 9/16".
- Finish: bright chrome.

RFID	A ["]	⚙ [mm]	d [mm]	d1 [mm]	d2 [mm]	L [mm]	L1 [mm]	ΔΔ [g]
R.3/16FRFID	3/16	12	13	8,0	13	61,6	5,3	35
R.7/32FRFID	7/32	12	13	8,5	13	62,4	6,1	35
R.1/4FRFID	1/4	12	13	9,8	13	62,8	6,5	35
R.9/32FRFID	9/32	12	13	10,5	13	62,8	6,5	35
R.5/16FRFID	5/16	12	13	12,0	13	63,3	7,0	35
R.11/32FRFID	11/32	12	13	13,3	13	63,3	7,0	40
R.3/8FRFID	3/8	12	13	13,7	13	64,6	8,3	45
R.7/16FRFID	7/16	12	13	15,5	21	54,8	9,5	60
R.1/2FRFID	1/2	12	13	18,0	21	55,8	10,5	65
R.9/16FRFID	9/16	12	13	19,2	21	55,8	10,5	65



Junior 3/8" range

3/8" ratchets

3/8" maintenance free pear head ratchet - RFID

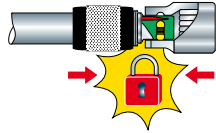
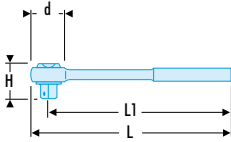

NF ISO 3315, ISO 3315, DIN 3122, ASME B107.10

- Tool with built-in RFID chip for workshop traceability.
- Chip integration by Facom guarantees maximum detection and strength, while preserving the tool's ergonomics.
- Radio frequency identification requires appropriate storage equipment.
- Dust proof, maintenance free mechanism.
- 72 teeth mechanism for 5° increments.
- Drive direction switch allows easy reversal even with gloved or greasy hands.
- Palm control system - allows the operator to press down on the head avoiding risk of accidental reverse.
- Ultra-compact head.
- Hook for hanging when working at height.
- Ergonomic comfort grip handle design resistant to workshop chemicals and solvents.

RFID	d [mm]	d1 [mm]	H [mm]	L [mm]	L1 [mm]	ΔΔ [g]
JL.171RFID	29	27	29	210	195	220

J.RC - 3/8" drive locking extensions - RFID

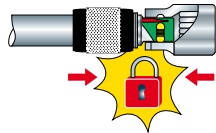
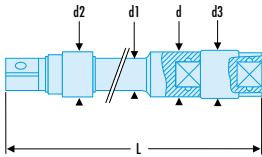

- Tool with built-in RFID chip for workshop traceability.
- Chip integration by Facom guarantees maximum detection and strength, while preserving the tool's ergonomics.
- Radio frequency identification requires appropriate storage equipment.
- Total safety as lock system prevents socket loss.
- Finish: bright chrome with phosphate-hardened ring.

RFID	L [mm]	d [mm]	d1 [mm]	d2 [mm]	d3 [mm]	ΔΔ [g]
J.210RCRFID	145	18	12,5	18	25	185
J.215RCRFID	270	18	12,5	18	25	290
J.217RCRFID	520	18	12,5	18	25	540

J - 3/8" drive extensions - RFID



- Tool with built-in RFID chip for workshop traceability.
- Chip integration by Facom guarantees maximum detection and strength, while preserving the tool's ergonomics.
- Radio frequency identification requires appropriate storage equipment.
- Finish: bright chrome.

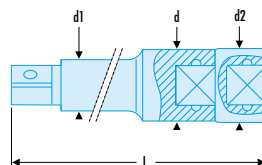

RFID	L [mm]	d [mm]	d1 [mm]	d2 [mm]	d3 [mm]	ΔΔ [g]
J.208RFID	70	18	10	12,6	25	115
J.209RFID	95	18	10	12,6	25	140

Junior 3/8" range

Ratchets - Sockets

3/8" universal joint - RFID

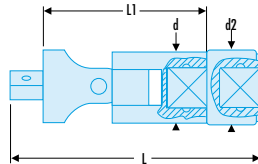

- Tool with built-in RFID chip for workshop traceability.
- Chip integration by Facom guarantees maximum detection and strength, while preserving the tool's ergonomics.
- Radio frequency identification requires appropriate storage equipment.
- Spring-stiffened joints.
- Finish: bright chrome.

RFID	d [mm]	d2 [mm]	L [mm]	L1 [mm]	ΔΔ [g]
J.240ARFID	18	25	71,5	36,5	110

3/8" to 1/4" coupler - RFID

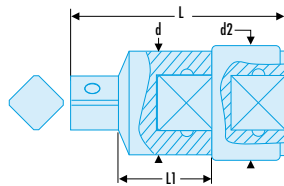

- Tool with built-in RFID chip for workshop traceability.
- Chip integration by Facom guarantees maximum detection and strength, while preserving the tool's ergonomics.
- Radio frequency identification requires appropriate storage equipment.
- For adapting 1/4" drive sockets.
- Max. torque 62 N.m.
- Finish: bright chrome.

RFID	d [mm]	d2 [mm]	L [mm]	L1 [mm]	ΔΔ [g]
J.230RFID	17,5	25	44,5	17	75

3/8" to 1/2" coupler - RFID

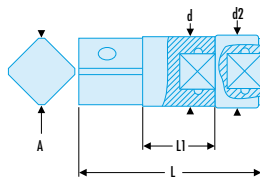

- Tool with built-in RFID chip for workshop traceability.
- Chip integration by Facom guarantees maximum detection and strength, while preserving the tool's ergonomics.
- Radio frequency identification requires appropriate storage equipment.
- For adapting 1/2" drive sockets.
- Finish: bright chrome.

RFID	A [mm]	d [mm]	d2 [mm]	L [mm]	L1 [mm]	ΔΔ [g]
J.232RFID	16,5	18	25	54,5	19	95



Junior 3/8" range

Solutions **FACOM.RFID**

3/8" sockets

J.H - 3/8" metric 6-point sockets - RFID

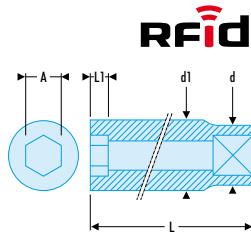

NF ISO 1711-1, ISO 1711-1

- Tool with built-in RFID chip for workshop traceability.
- Chip integration by Facom guarantees maximum detection and strength, while preserving the tool's ergonomics.
- Radio frequency identification requires appropriate storage equipment.
- OGV® profile: more powerful tightening, preserves fasteners.
- Metric dimensions : from 7 to 24 mm.
- Finish: bright chrome.

☞	A [mm]	⊘ [mm]	d [mm]	d1 [mm]	d2 [mm]	L [mm]	L1 [mm]	ΔΔ [g]
J.7HRFID	7	6	17,6	11,0	25	47	6,0	75
J.8HRFID	8	6	17,6	12,2	25	47	6,5	75
J.9HRFID	9	6	17,6	13,5	25	47	6,7	75
J.10HRFID	10	6	17,6	14,7	25	47	7,8	80
J.11HRFID	11	6	17,6	16,0	25	47	9,0	80
J.12HRFID	12	6	17,6	17,2	25	47	9,5	80
J.13HRFID	13	6	17,4	18,3	25	50	10,4	90
J.14HRFID	14	6	17,6	19,5	25	50	10,5	85

☞	A [mm]	⊘ [mm]	d [mm]	d1 [mm]	d2 [mm]	L [mm]	L1 [mm]	ΔΔ [g]
J.15HRFID	15	6	18,9	20,8	25	50	12,0	90
J.16HRFID	16	6	19,9	22,0	25	50	12,0	95
J.17HRFID	17	6	21,7	23,4	25	50	13,0	105
J.18HRFID	18	6	21,7	24,7	25	53	13,0	120
J.19HRFID	19	6	22,7	26,0	25	53	14,0	115
J.21HRFID	21	6	23,5	28,5	25	53	16,0	125
J.22HRFID	22	6	24,7	29,7	25	53	16,5	130
J.24HRFID	24	6	26,3	31,3	25	53	16,5	140

J - 3/8" metric 12-point sockets - RFID

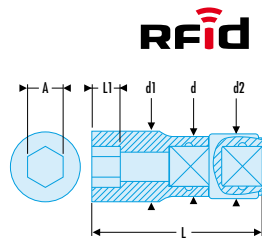

NF ISO 1711-1, ISO 1711-1

- Tool with built-in RFID chip for workshop traceability.
- Chip integration by Facom guarantees maximum detection and strength, while preserving the tool's ergonomics.
- Radio frequency identification requires appropriate storage equipment.
- OGV® profile: more powerful tightening, preserves fasteners.
- Metric dimensions : from 7 to 24 mm.
- Finish: bright chrome.

☞	A [mm]	⊘ [mm]	d [mm]	d1 [mm]	d2 [mm]	L [mm]	L1 [mm]	ΔΔ [g]
J.7RFID	7	12	17,6	11,0	25	47	6,0	75
J.8RFID	8	12	17,6	12,2	25	47	6,5	75
J.9RFID	9	12	17,6	13,5	25	47	6,7	75
J.10RFID	10	12	17,6	14,7	25	47	7,8	80
J.11RFID	11	12	17,6	16,0	25	47	9,0	80
J.12RFID	12	12	17,6	17,2	25	47	9,5	80
J.13RFID	13	12	17,5	18,3	25	50	10,4	90
J.14RFID	14	12	17,7	19,5	25	50	10,5	85

☞	A [mm]	⊘ [mm]	d [mm]	d1 [mm]	d2 [mm]	L [mm]	L1 [mm]	ΔΔ [g]
J.15RFID	15	12	19,0	20,8	25	50	12,0	90
J.16RFID	16	12	20,0	22,0	25	50	12,0	95
J.17RFID	17	12	21,7	23,4	25	50	13,0	105
J.18RFID	18	12	21,7	24,7	25	53	13,0	120
J.19RFID	19	12	22,7	26,0	25	53	14,0	115
J.21RFID	21	12	23,5	28,5	25	53	16,0	125
J.22RFID	22	12	24,7	29,7	25	53	16,5	130
J.24RFID	24	12	26,3	31,3	25	53	16,5	140

J - 3/8" inch 12-point sockets - RFID

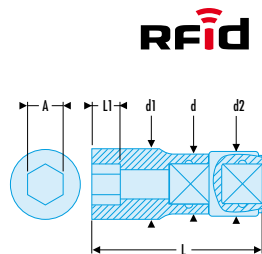

- Tool with built-in RFID chip for workshop traceability.
- Chip integration by Facom guarantees maximum detection and strength, while preserving the tool's ergonomics.
- Radio frequency identification requires appropriate storage equipment.
- OGV® profile: more powerful tightening, preserves fasteners.
- Dimensions in inches: from 1/4" to 1".
- Finish: bright chrome.

☞	A ["]	⊘ [mm]	d [mm]	d1 [mm]	d2 [mm]	L [mm]	L1 [mm]	ΔΔ [g]
J.1/4RFID	1/4	12	17,5	10,0	25	47	6,0	75
J.5/16RFID	5/16	12	17,5	11,9	25	47	6,5	75
J.3/8RFID	3/8	12	17,6	14,1	25	47	7,5	80
J.7/16RFID	7/16	12	17,5	16,0	25	47	9,0	80
J.1/2RFID	1/2	12	17,5	18,1	25	50	10,4	90
J.9/16RFID	9/16	12	17,7	19,5	25	50	10,5	85
J.5/8RFID	5/8	12	20,0	22,0	25	50	12,0	100

☞	A ["]	⊘ [mm]	d [mm]	d1 [mm]	d2 [mm]	L [mm]	L1 [mm]	ΔΔ [g]
J.11/16RFID	11/16	12	21,0	24,0	25	53	13,0	125
J.3/4RFID	3/4	12	22,7	26,0	25	53	14,0	130
J.13/16RFID	13/16	12	23,0	28,0	25	53	16,0	130
J.7/8RFID	7/8	12	24,7	29,7	25	53	16,5	155
J.15/16RFID	15/16	12	26,3	31,3	25	53	16,5	190
J.1PRFID	1	12	28,3	33,3	25	53	16,5	210

Junior 3/8" range

Ratchets - Sockets

3/8" long-reach sockets

J.HLA - 3/8" long-reach metric 6-point sockets - RFID

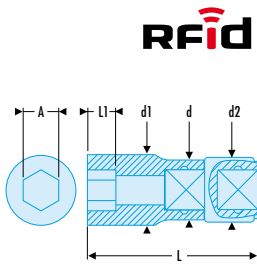

NF ISO 1711-1, ISO 1711-1

- Tool with built-in RFID chip for workshop traceability.
- Chip integration by Facom guarantees maximum detection and strength, while preserving the tool's ergonomics.
- Radio frequency identification requires appropriate storage equipment.
- OGV® profile: more powerful tightening, preserves fasteners.
- Long-reach sockets for long recess or thread access.
- Metric dimensions : from 7 to 24 mm.
- Finish: bright chrome.

Socket	A [mm]	⌀ [mm]	d [mm]	d1 [mm]	d2 [mm]	L [mm]	L1 [mm]	ΔΔ [g]
J.7HLARFID	7	6	17,3	10,6	25	75	6,0	95
J.8HLARFID	8	6	17,3	12,0	25	75	7,5	100
J.9HLARFID	9	6	17,3	13,0	25	75	7,5	100
J.10HLARFID	10	6	17,3	14,5	25	75	9,0	100
J.11HLARFID	11	6	17,3	16,0	25	75	10,5	105
J.12HLARFID	12	6	17,2	16,8	25	75	12,0	105
J.13HLARFID	13	6	17,0	18,0	25	75	12,0	105
J.14HLARFID	14	6	18,0	20,0	25	75	15,0	110

Socket	A [mm]	⌀ [mm]	d [mm]	d1 [mm]	d2 [mm]	L [mm]	L1 [mm]	ΔΔ [g]
J.15HLARFID	15	6	20,0	21,0	25	80	15,0	125
J.16HLARFID	16	6	20,0	22,0	25	80	15,0	135
J.17HLARFID	17	6	22,0	23,5	25	80	15,0	155
J.18HLARFID	18	6	23,0	24,5	25	80	18,0	160
J.19HLARFID	19	6	24,0	25,0	25	80	18,0	160
J.21HLARFID	21	6	26,0	27,0	25	80	18,0	175
J.22HLARFID	22	6	28,0	29,0	25	80	21,0	200
J.24HLARFID	24	6	30,0	31,0	25	80	24,0	230

J.LA - 3/8" long-reach metric 12-point sockets - RFID

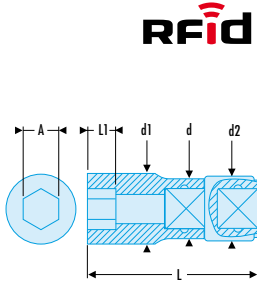

NF ISO 1711-1, ISO 1711-1

- Tool with built-in RFID chip for workshop traceability.
- Chip integration by Facom guarantees maximum detection and strength, while preserving the tool's ergonomics.
- Radio frequency identification requires appropriate storage equipment.
- OGV® profile: more powerful tightening, preserves fasteners.
- Long-reach sockets for long recess or thread access.
- Metric dimensions : from 7 to 24 mm.
- Finish: bright chrome.

Socket	A [mm]	⌀ [mm]	d [mm]	d1 [mm]	d2 [mm]	L [mm]	L1 [mm]	ΔΔ [g]
J.7LARFID	7	12	17,3	10,6	25	75	6,0	95
J.8LARFID	8	12	17,3	12,0	25	75	7,5	100
J.9LARFID	9	12	17,3	13,0	25	75	7,5	100
J.10LARFID	10	12	17,3	14,5	25	75	9,0	100
J.11LARFID	11	12	17,3	16,0	25	75	10,5	105
J.12LARFID	12	12	17,3	16,8	25	75	12,0	105
J.13LARFID	13	12	17,2	18,0	25	75	12,0	105
J.14LARFID	14	12	17	20,0	25	75	15,0	110

Socket	A [mm]	⌀ [mm]	d [mm]	d1 [mm]	d2 [mm]	L [mm]	L1 [mm]	ΔΔ [g]
J.15LARFID	15	12	18	21,0	25	75	15,0	125
J.16LARFID	16	12	20	22,0	25	80	15,0	135
J.17LARFID	17	12	20	23,5	25	80	15,0	155
J.18LARFID	18	12	22	24,5	25	80	18,0	160
J.19LARFID	19	12	23	25,0	25	80	18,0	160
J.21LARFID	21	12	24	27,0	25	80	18,0	175
J.22LARFID	22	12	26	29,0	25	80	21,0	200
J.24LARFID	24	12	30	31,0	25	80	21,0	230

J.LA - 3/8" inch 12-point sockets - RFID

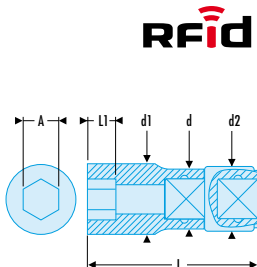

- Tool with built-in RFID chip for workshop traceability.
- Chip integration by Facom guarantees maximum detection and strength, while preserving the tool's ergonomics.
- Radio frequency identification requires appropriate storage equipment.
- OGV® profile: more powerful tightening, preserves fasteners.
- Long-reach sockets for long recess or thread access.
- Dimensions in inches: from 1/4" to 1".
- Finish: bright chrome.

Socket	A ["]	⌀ [mm]	d [mm]	d1 [mm]	d2 [mm]	L [mm]	L1 [mm]	ΔΔ [g]
J.1/4LARFID	1/4	12	17,5	10,6	25	64,7	4,0	90
J.5/16LARFID	5/16	12	17,5	12,4	25	64,7	4,3	90
J.3/8LARFID	3/8	12	17,5	14,3	25	64,7	4,7	95
J.7/16LARFID	7/16	12	17,5	16,2	25	64,7	6,2	95
J.1/2LARFID	1/2	12	18,2	18,2	25	64,7	7,4	100
J.9/16LARFID	9/16	12	20,5	20,5	25	68	9,0	125
J.5/8LARFID	5/8	12	22,3	22,3	25	83,8	10,2	155

Socket	A ["]	⌀ [mm]	d [mm]	d1 [mm]	d2 [mm]	L [mm]	L1 [mm]	ΔΔ [g]
J.11/16LARFID	11/16	12	23,8	23,8	25	83,8	10,2	165
J.3/4LARFID	3/4	12	25,3	25,3	25	83,8	11,8	170
J.13/16LARFID	13/16	12	27,0	27,0	25	83,8	12,3	190
J.7/8LARFID	7/8	12	30,2	30,2	25	83,8	12,7	235
J.15/16LARFID	15/16	12	31,8	31,8	25	83,8	12,7	235
J.1PLARFID	1	12	33,4	33,4	25	83,8	12,7	235

Junior 3/8" range

■ J.F - 3/8" drive hinged inch 12-point sockets RFID



RFid

- Tool with built-in RFID chip for workshop traceability.
- Chip integration by Facom guarantees maximum detection and strength, while preserving the tool's ergonomics.
- Radio frequency identification requires appropriate storage equipment.
- OGV® profile: more powerful tightening, preserves fasteners.
- Compact solution used instead of universal joint.
- Dimensions in inches: from 3/8" to 3/4".
- Finish: bright chrome.

Socket	A ["]	Drive [mm]	d [mm]	d1 [mm]	d2 [mm]	L [mm]	L1 [mm]	ΔΔ [g]
J.3/8FRFID	3/8	12	19	14,0	25	67,5	8,3	105
J.7/16FRFID	7/16	12	19	15,8	25	70,5	9,8	110
J.1/2FRFID	1/2	12	19	18,3	25	69	11,3	105
J.9/16FRFID	9/16	12	19	19,5	25	70,5	11,3	110
J.5/8FRFID	5/8	12	19	22,00	25	73,5	12,8	120
J.11/16FRFID	11/16	12	19	24,00	25	74,5	13,8	125
J.3/4FRFID	3/4	12	19	25,8	25	76,5	15,8	130



Standard 1/2" range

Ratchets - Sockets

1/2" ratchets

1/2" maintenance free pear head ratchet - RFID

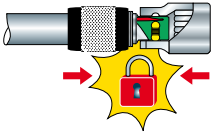

RFID

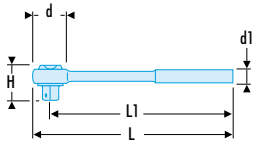

NF ISO 3315, ISO 3315, DIN 3122, ASME B107.10

- Tool with built-in RFID chip for workshop traceability.
- Chip integration by Facom guarantees maximum detection and strength, while preserving the tool's ergonomics.
- Radio frequency identification requires appropriate storage equipment.
- Dust proof, maintenance free mechanism.
- 72 teeth mechanism for 5° increments.
- Drive direction switch allows easy reversal even with gloved or greasy hands.
- Palm control system - allows the operator to press down on the head avoiding risk of accidental reverse.
- Ultra-compact head.
- Hook for hanging when working at height.
- Ergonomic comfort grip handle design resistant to workshop chemicals and solvents.

RFID	d [mm]	d1 [mm]	H [mm]	L [mm]	L1 [mm]	ΔΔ [g]
SL.171RFID	37	32	37	262	245	470

S.RC - 1/2" drive locking extensions - RFID

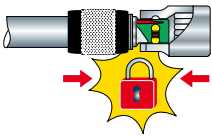

RFID

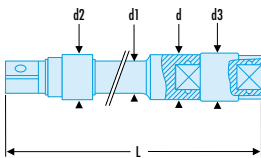

- Tool with built-in RFID chip for workshop traceability.
- Chip integration by Facom guarantees maximum detection and strength, while preserving the tool's ergonomics.
- Radio frequency identification requires appropriate storage equipment.
- Total safety as lock system prevents socket loss.
- Safety and instant release, by retracting knurled ring, for total user confidence.
- Positive locking for use with sockets with internal ball notch.
- Finish: bright chrome with phosphate-hardened ring.

RFID	L [mm]	d [mm]	d1 [mm]	d2 [mm]	d3 [mm]	E [mm]	ΔΔ [g]
S.210RCRFID	154	23	16,5	23	29	16,5	330
S.215RCRFID	274	23	16,5	23	29	16,5	530
S.217RCRFID	524	23	16,5	23	29	16,5	940

S - 1/2" drive extensions - RFID



RFID

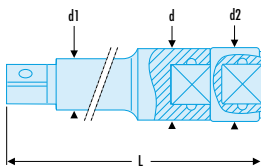

- Tool with built-in RFID chip for workshop traceability.
- Chip integration by Facom guarantees maximum detection and strength, while preserving the tool's ergonomics.
- Radio frequency identification requires appropriate storage equipment.
- Finish: bright chrome.

RFID	L [mm]	d [mm]	d1 [mm]	d2 [mm]	ΔΔ [g]
S.206RFID	549	23	16,5	29	170
S.208RFID	99	23	16,5	29	210



Standard 1/2" range

1/2" universal joint - RFID



RFID

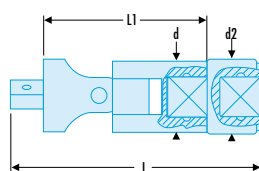

- Tool with built-in RFID chip for workshop traceability.
- Chip integration by Facom guarantees maximum detection and strength, while preserving the tool's ergonomics.
- Radio frequency identification requires appropriate storage equipment.
- Spring-stiffened joint.
- Stays in position when reaching for fasteners.
- Significant time savings.
- Finish: bright chrome.

RFID	d [mm]	d2 [mm]	L [mm]	L1 [mm]	ΔΔ [g]
S.240ARFID	23	29	90	51	240

1/2" to 3/8" coupler - RFID



RFID

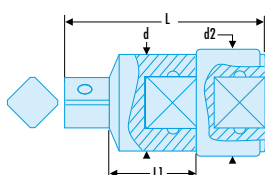

- Tool with built-in RFID chip for workshop traceability.
- Chip integration by Facom guarantees maximum detection and strength, while preserving the tool's ergonomics.
- Radio frequency identification requires appropriate storage equipment.
- Double 3/8" coupler
- Max torque: 212 N.m.
- Finish: bright chrome.

RFID	d [mm]	d2 [mm]	L [mm]	L1 [mm]	ΔΔ [g]
S.230RFID	23	29	57,5	23	135

1/2" sockets

S.H - 1/2" metric 6-point sockets - RFID



RFID

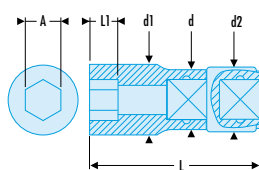

NF ISO 1711-1, ISO 1711-1

- Tool with built-in RFID chip for workshop traceability.
- Chip integration by Facom guarantees maximum detection and strength, while preserving the tool's ergonomics.
- Radio frequency identification requires appropriate storage equipment.
- OGV® profile: more powerful tightening, preserves fasteners.
- Finish: bright chrome.

RFID	A [mm]	⌀ [mm]	d [mm]	d1 [mm]	d2 [mm]	L [mm]	L1 [mm]	ΔΔ [g]
S.10HRFID	10	6	22,8	15,3	29	60	7,8	130
S.11HRFID	11	6	22,8	16,5	29	60	9,0	135
S.12HRFID	12	6	22,8	17,8	29	60	9,5	135
S.13HRFID	13	6	22,8	18,9	29	60	10,4	135
S.14HRFID	14	6	22,8	20,2	29	60	10,5	140
S.15HRFID	15	6	22,8	21,4	29	60	12,0	140
S.16HRFID	16	6	21,6	22,6	29	60	12,0	140
S.17HRFID	17	6	23,1	24,1	29	60	13,0	145
S.18HRFID	18	6	23,4	25,5	29	60	13,0	150
S.19HRFID	19	6	24,6	26,6	29	60	14,0	150
S.21HRFID	21	6	25,1	29,1	29	62	16,0	175
S.22HRFID	22	6	26,4	30,4	29	62	16,5	185
S.24HRFID	24	6	28,7	32,7	29	62	16,5	210
S.27HRFID	27	6	29,2	36,6	29	68	19,0	220
S.30HRFID	30	6	33,0	40,4	29	68	20,0	285
S.32HRFID	32	6	35,1	42,6	29	68	20,0	295
S.34HRFID	34	6	37,5	44,9	29	68	20,0	320

Standard 1/2" range

Ratchets - Sockets

■ S - 1/2" metric 12-point sockets - RFID



NF ISO 1711-1, ISO 1711-1

- Tool with built-in RFID chip for workshop traceability.
- Chip integration by Facom guarantees maximum detection and strength, while preserving the tool's ergonomics.
- Radio frequency identification requires appropriate storage equipment.
- OGV® profile: more powerful tightening, preserves fasteners.
- Metric dimensions : from 10 to 34 mm.
- Finish: bright chrome.

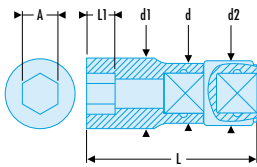

RFID	A [mm]	⚙️ [mm]	d [mm]	d1 [mm]	d2 [mm]	L [mm]	L1 [mm]	ΔΔ [g]
S.10RFID	10	12	22,8	15,3	29	60	7,8	130
S.11RFID	11	12	22,8	16,5	29	60	9,0	135
S.12RFID	12	12	22,8	17,8	29	60	9,5	135
S.13RFID	13	12	22,8	18,9	29	60	10,4	135
S.14RFID	14	12	22,8	20,2	29	60	10,5	140
S.15RFID	15	12	22,8	21,4	29	60	12,0	140
S.16RFID	16	12	21,6	22,6	29	60	12,0	140
S.17RFID	17	12	23,1	24,1	29	60	13,0	145
S.18RFID	18	12	23,4	25,4	29	60	13,0	150
S.19RFID	19	12	24,6	26,6	29	60	14,0	150
S.21RFID	21	12	25,1	29,1	29	62	16,0	175
S.22RFID	22	12	26,4	30,4	29	62	16,5	185
S.24RFID	24	12	28,7	32,7	29	62	16,5	210
S.27RFID	27	12	29,2	36,6	29	68	19,0	225
S.30RFID	30	12	33,0	40,4	29	68	20,0	265
S.32RFID	32	12	35,1	42,5	29	68	20,0	280
S.34RFID	34	12	37,5	44,9	29	68	20,0	305

■ S - 1/2" metric 12-point sockets - RFID



- Tool with built-in RFID chip for workshop traceability.
- Chip integration by Facom guarantees maximum detection and strength, while preserving the tool's ergonomics.
- Radio frequency identification requires appropriate storage equipment.
- OGV® profile: more powerful tightening, preserves fasteners.
- Dimensions in inches: from 3/8" to 1 1/4".
- Finish: bright chrome.

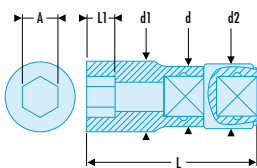

RFID	A ["]	⚙️ [mm]	d [mm]	d1 [mm]	d2 [mm]	L [mm]	L1 [mm]	ΔΔ [g]
S.3/8RFID	3/8	12	22,8	14,7	29	60	7,8	130
S.7/16RFID	7/16	12	22,8	16,5	29	60	9,0	135
S.1/2RFID	1/2	12	22,8	18,9	29	60	10,4	135
S.9/16RFID	9/16	12	22,8	20,2	29	60	10,5	140
S.19/32RFID	19/32	12	22,8	21,4	29	60	12,0	140
S.5/8RFID	5/8	12	21,6	22,6	29	60	12,0	145
S.21/32RFID	21/32	12	23,1	24,1	29	60	13,0	145
S.11/16RFID	11/16	12	22,6	24,6	29	60	13,0	155
S.3/4RFID	3/4	12	25,0	27,0	29	60	14,0	150
S.25/32RFID	25/32	12	25,9	27,9	29	60	14,0	155
S.13/16RFID	13/16	12	24,6	28,6	29	62	16,0	180
S.7/8RFID	7/8	12	26,4	30,4	29	62	16,5	180
S.15/16RFID	15/16	12	28,7	32,7	29	62	16,5	215
S.31/32RFID	31/32	12	27,7	34,1	29	62	16,5	215
S.1PRFID	1	12	28,3	34,7	29	62	16,5	225
S.1P1/16RFID	1 1/16	12	29,2	36,6	29	68	19,0	230
S.1P1/8RFID	1 1/8	12	31,3	38,7	29	68	20,0	250
S.1P3/16RFID	1 3/16	12	33,0	40,4	29	68	20,0	265
S.1P1/4RFID	1 1/4	12	35,1	42,5	29	68	20,0	285

Standard 1/2" range

Solutions **FACOM.RFID**

1/2" long-reach sockets

■ S.HLA - 1/2" long-reach metric 6-point sockets - RFID



RFID

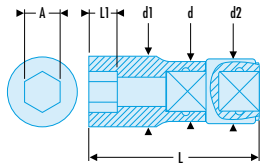

NF ISO 1711-1, ISO 1711-1

- Tool with built-in RFID chip for workshop traceability.
- Chip integration by Facom guarantees maximum detection and strength, while preserving the tool's ergonomics.
- Radio frequency identification requires appropriate storage equipment.
- OGV® profile: more powerful tightening, preserves fasteners.
- Long-reach sockets for long recess or thread access.
- Metric dimensions : from 12 to 32 mm.
- Finish: bright chrome.

RFID	A [mm]	⌀ [mm]	d [mm]	d1 [mm]	d2 [mm]	L [mm]	L1 [mm]	ΔΔ [g]
S.12HLARFID	12	6	21	17,8	29	101	12	185
S.13HLARFID	13	6	21,8	19,0	29	101	12	195
S.14HLARFID	14	6	21,8	20,3	29	101	15	200
S.15HLARFID	15	6	21,8	21,5	29	101	15	205
S.16HLARFID	16	6	22,0	22,8	29	101	15	210
S.17HLARFID	17	6	23,0	24,0	29	101	15	220
S.18HLARFID	18	6	24,0	25,0	29	101	18	240
S.19HLARFID	19	6	25,0	26,5	29	101	18	240
S.21HLARFID	21	6	27,0	29,0	29	101	18	280
S.22HLARFID	22	6	28,0	30,0	29	101	21	295
S.24HLARFID	24	6	30,0	32,8	29	101	24	335
S.27HLARFID	27	6	33,0	36,5	29	101	27	390
S.30HLARFID	30	6	36,0	40,0	29	101	30	435
S.32HLARFID	32	6	38,0	42,8	29	101	33	490

■ S.LA - 1/2" long-reach metric 12-point sockets - RFID



RFID

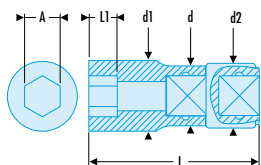

NF ISO 1711-1, ISO 1711-1

- Tool with built-in RFID chip for workshop traceability.
- Chip integration by Facom guarantees maximum detection and strength, while preserving the tool's ergonomics.
- Radio frequency identification requires appropriate storage equipment.
- OGV® profile: more powerful tightening, preserves fasteners.
- Long-reach sockets for long recess or thread access.
- Metric dimensions : from 12 to 32 mm.
- Finish: bright chrome.

RFID	A [mm]	⌀ [mm]	d [mm]	d1 [mm]	d2 [mm]	L [mm]	L1 [mm]	ΔΔ [g]
S.12LARFID	12	12	21,0	17,8	29	101	12	185
S.13LARFID	13	12	21,8	19,0	29	101	12	195
S.14LARFID	14	12	21,8	20,3	29	101	15	205
S.15LARFID	15	12	21,8	21,5	29	101	15	205
S.16LARFID	16	12	22,0	22,8	29	101	15	215
S.17LARFID	17	12	23,0	24,0	29	101	15	225
S.18LARFID	18	12	24,0	25,0	29	101	18	240
S.19LARFID	19	12	25,0	26,5	29	101	18	260
S.21LARFID	21	12	27,0	29,0	29	101	18	290
S.22LARFID	22	12	28,0	30,0	29	101	21	295
S.24LARFID	24	12	30,0	32,8	29	101	24	335
S.27LARFID	27	12	33,0	36,5	29	101	27	395
S.30LARFID	30	12	36,0	40,0	29	101	30	445
S.32LARFID	32	12	36,0	42,8	29	101	33	495

Standard 1/2" range

Ratchets - Sockets

S.LA - 1/2" inch 12-point sockets - RFID



- Tool with built-in RFID chip for workshop traceability.
- Chip integration by Facom guarantees maximum detection and strength, while preserving the tool's ergonomics.
- Radio frequency identification requires appropriate storage equipment.
- OGV® profile: more powerful tightening, preserves fasteners.
- Long-reach sockets for long recess or thread access.
- Dimensions in inches: from 1/2" to 1 1/4".
- Finish: bright chrome.

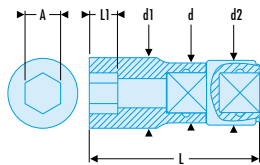

	A ["]	⚙ [mm]	d [mm]	d1 [mm]	d2 [mm]	L [mm]	L1 [mm]	ΔΔ [g]
S.1/2LARFID	1/2	12	22,3	19,0	29	106,2	8,1	215
S.9/16LARFID	9/16	12	22,3	20,6	29	106,2	9,6	220
S.5/8LARFID	5/8	12	22,3	22,3	29	106,2	10,9	230
S.11/16LARFID	11/16	12	24,4	24,4	29	106,2	10,9	240
S.3/4LARFID	3/4	12	26,9	26,9	29	106,2	12,4	245
S.13/16LARFID	13/16	12	28,7	28,7	29	106,2	12,9	255
S.7/8LARFID	7/8	12	30,2	30,2	29	106,2	14,0	280
S.15/16LARFID	15/16	12	31,7	31,7	29	106,2	15,0	305
S.1PLARFID	1	12	33,3	33,3	29	106,2	15,2	335
S.1P1/16LARFID	1 1/16	12	36,5	36,5	29	106,2	16,0	400
S.1P1/8LARFID	1 1/8	12	38,1	38,1	29	106,2	16,7	430
S.1P1/4LARFID	1 1/4	12	42,9	42,9	29	106,2	16,7	510



Torque wrenches

“High performance” click wrenches

Solutions FACOM.RFid

306 SERIES

CLICK WRENCHES

“HIGH PERFORMANCE”

WRENCHES

FACOM.RFid

TRACEABILITY

- Tool with built-in RFID chip for workshop traceability.
- Chip integration by Facom guarantees maximum detection and strength, while preserving the tool's ergonomics.
- Radio frequency identification requires appropriate storage equipment.

REAL-TIME MANAGEMENT OF CALIBRATION CERTIFICATES



PERFORMANCE

- Accurate, tamper-proof vernier. Easy to read and set for error-free adjustment.
- Automatically locking torque adjustment, no risk of accidental release.

PRECISION

- Accurate, tamper-proof vernier. Easy to read and set for error-free adjustment.
- Automatically locking torque adjustment, no risk of accidental release.

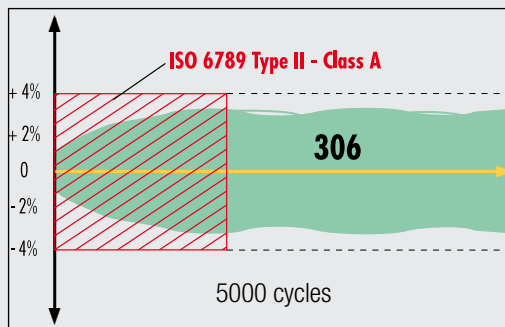

RFid
TECHNOLOGY
BY FACOM

Torque wrenches

Torque control

306D - Click wrenches without accessories - RFID



NF EN ISO 6789, ISO 6789, DIN EN ISO 6789

- Tool with built-in RFID chip for workshop traceability.
- Chip integration by Facom guarantees maximum detection and strength, while preserving the tool's ergonomics.
- Radio frequency identification requires appropriate storage equipment.
- Factory accuracy: ± 2% except: - R.306-25DRFID (± 4%).
- R.304DARFID (± 6%).
- Reliability of mechanism: 50,000 cycles (wrenches up to 200 N.m).
- Use possible with accessories: End fitting: 9 x 12 or 14 x 18 mm.
- One-way wrenches usable for unscrewing by reversing the bits.
- Numbered wrenches supplied with ISO 6789 calibration certificate.

➔	Capacity [N.m]	End Fitting	Graduation [N.m]	L [mm]	ΔΔ [kg]
R.304DARFID	1 - 5	9 x 12	0,05	211,5	0,35
R.306-25DRFID	5 - 25	9 x 12	0,10	271	0,51
J.306-50DRFID	10 - 50	9 x 12	1,00	357	0,96
S.306-100DRFID	20 - 100	9 x 12	1,00	437	1,07
S.306-200DRFID	40 - 200	14 x 18	1,00	515	1,28
S.306-350DRFID	70 - 350	14 x 18	2,00	725	1,81



"Low torque" click wrench with fixed ratchet - RFID



NF EN ISO 6789, ISO 6789, DIN EN ISO 6789

- Tool with built-in RFID chip for workshop traceability.
- Chip integration by Facom guarantees maximum detection and strength, while preserving the tool's ergonomics.
- Radio frequency identification requires appropriate storage equipment.
- Factory accuracy: ± 6%. - Reliability of mechanism: 50,000 cycles.
- Compact wrench for confined access. - Ratchet with 72 teeth (5°) for use with sockets.
- One-way wrench. - Numbered wrench supplied with ISO 6789 calibration certificate.

➔	Capacity [N.m]	Graduation [N.m]	∠ [°]	L [mm]	ΔΔ [kg]
R.306-5RFID	1 - 5	0,05	1/4	215	0,36



R-J.306U - Click wrenches with dual lbf.in and N.m graduation - RFID



NF EN ISO 6789, ISO 6789, DIN EN ISO 6789

- Tool with built-in RFID chip for workshop traceability.
- Chip integration by Facom guarantees maximum detection and strength, while preserving the tool's ergonomics.
- Radio frequency identification requires appropriate storage equipment.
- Factory accuracy: ± 2%. - Reliability of mechanism: 50,000 cycles.
- Click wrenches with dual lbf.in and N.m graduation. - Full metal wrenches with knurled handle.
- Reversible model. - Numbered wrenches supplied with ISO 6789 calibration certificate.

➔	Capacity [lbf.in]	End Fitting	Graduation [lbf.in]	∠ [°]	L [mm]	ΔΔ [kg]
R.306URFID	40 - 200	9 x 12	1	1/4	303,7	0,52
J.306URFID	200 - 1000	9 x 12	5	3/8	397	1,11



S.305P Swivel handle - RFID



- Tool with built-in RFID chip for workshop traceability.
- Chip integration by Facom guarantees maximum detection and strength, while preserving the tool's ergonomics.
- Radio frequency identification requires appropriate storage equipment.
- Ability to keep the wrench parallel with the tightening plane.
- Use with 3/8" and 1/2" ratchets and drive squares.
- Max diam. size: 45 mm.
- Length: 66 mm.
- Weight: 130 g.



Screwdrivers

PROTWIST® screwdrivers

AN-AW - PROTWIST® screwdrivers for slotted head screws - RFID

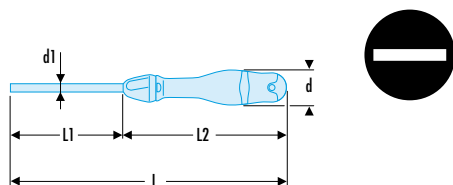

NF ISO 2380-1, NF ISO 2380-2, ISO 2380-1, ISO 2380-2, DIN ISO 2380-1, DIN ISO 2380-2, ASME B107.600

- Tool with built-in RFID chip for workshop traceability.
- Chip integration by Facom guarantees maximum detection and strength, while preserving the tool's ergonomics.
- Radio frequency identification requires appropriate storage equipment.
- Silicon carbon blade: strong and resistant to flexion.
- Bi-material grip resists to impacts, abrasion, and chemicals.

➤	A [mm]	E [mm]	d [mm]	d1 x L1 [mm]	L [mm]	L2 [mm]	ΔΔ [g]
AN2X75RFID	2,0	0,4	19	2,0 x 58	169	94	60
AN2.5X75RFID	2,5	0,4	19	2,5 x 58	169	94	65
AN3X100RFID	3,0	0,5	25	3,0 x 83	203	103	75
AN3.5X100RFID	3,5	0,6	25	3,5 x 82	203	103	85
AN4X100RFID	4,0	0,8	30	4,0 x 82	209	109	90
AN4X150RFID	4,0	0,8	30	4,0 x 132	259	109	95
AN5.5X150RFID	5,5	1,0	30	5,5 x 132	259	109	135
AN6.5X150RFID	6,5	1,2	36	6,5 x 131	270	120	180
AW8X150RFID	8	1,2	40	7 x 131	275	125	260
AW10X200RFID	10	1,6	40	9 x 181	325	125	295

ANP - PROTWIST® screwdrivers for Phillips® screws - RFID

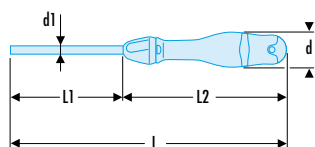

NF ISO 8764-1, NF ISO 8764-2, ISO 8764-1, ISO 8764-2, DIN ISO 8764-1, DIN ISO 8764-2, ASME B107.600

- Tool with built-in RFID chip for workshop traceability.
- Chip integration by Facom guarantees maximum detection and strength, while preserving the tool's ergonomics.
- Radio frequency identification requires appropriate storage equipment.
- Silicon carbon blade: strong and resistant to flexion.
- Bi-material grip resists to impacts, abrasion, and chemicals.

➤	Phillips [No]	d [mm]	d1 x L1 [mm]	L [mm]	L2 [mm]	ΔΔ [g]
ANPOX75RFID	PH0	25	3,0 x 57	178	103	85
ANP1X100RFID	PH1	30	4,5 x 82	209	109	120
ANP1X250RFID	PH1	30	4,5 x 232	359	109	140
ANP2X125RFID	PH2	36	6,0 x 106	245	120	170
ANP2X250RFID	PH2	36	6,0 x 231	370	120	195
ANP2X400RFID	PH2	36	6,0 x 381	520	120	230
ANP3X150RFID	PH3	40	8,0 x 131	275	125	235
ANP1X35RFID	PH1	36	4,5 x 25	91	56	70
ANP2X35RFID	PH2	36	6,0 x 25	91	56	75

Screwdrivers

Screwdrivers - Keys

AND - PROTWIST® screwdrivers for Pozidriv® screws - RFID

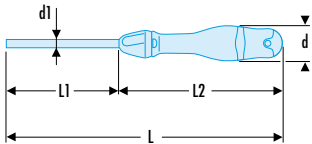

NF ISO 2380-1, NF ISO 2380-2, ISO 2380-1, ISO 2380-2, DIN ISO 2380-1, DIN ISO 2380-2, ASME B107.600

- Tool with built-in RFID chip for workshop traceability.
- Chip integration by Facom guarantees maximum detection and strength, while preserving the tool's ergonomics.
- Radio frequency identification requires appropriate storage equipment.
- Silicon carbon blade: strong and resistant to flexion.
- Bi-material grip resists to impacts, abrasion, and chemicals.
- Finish: black tipped mat chromed round blade.

REF	Phillips [No]	d [mm]	d1 x L1 [mm]	L [mm]	L2 [mm]	ΔΔ [g]
AND0X75FRFID	PZ0	25	3,0 x 57	178	103	85
AND1X100FRFID	PZ1	30	4,5 x 82	209	109	120
AND1X250FRFID	PZ1	30	4,5 x 232	359	109	140
AND2X125FRFID	PZ2	36	6,0 x 106	245	120	170
AND2X250FRFID	PZ2	36	6,0 x 231	370	120	195
AND3X150FRFID	PZ3	40	8,0 x 131	275	125	235
AND1X35FRFID	PZ1	36	4,5 x 25	91	56	70
AND2X35FRFID	PZ2	36	6,0 x 25	91	56	75

ANXR - PROTWIST® screwdrivers for Resistorx® screws - RFID

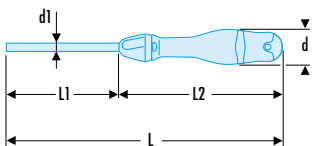

- Tool with built-in RFID chip for workshop traceability.
- Chip integration by Facom guarantees maximum detection and strength, while preserving the tool's ergonomics.
- Radio frequency identification requires appropriate storage equipment.
- Compliant with Resistorx® specifications.
- Silicon carbon blade: strong and resistant to flexion.
- Bi-material grip resists to impacts, abrasion, and chemicals.
- Finish: black tipped mat chromed blade.

REF	A [mm]	Resistorx [No]	d [mm]	d1 x L1 [mm]	L [mm]	L2 [mm]	ΔΔ [g]
ANXR10X75FRFID	2,74	TT10	25	3,0 x 57	184	109	90
ANXR15X75FRFID	3,26	TT15	30	3,5 x 57	185	110	105
ANXR20X100FRFID	3,84	TT20	36	4,0 x 81	220	120	110
ANXR25X100FRFID	4,40	TT25	36	5,0 x 81	220	120	155
ANXR27X100FRFID	4,96	TT27	36	5,5 x 81	220	120	155
ANXR30X125FRFID	5,49	TT30	36	6,0 x 106	245	120	170
ANXR40X150FRFID	6,60	TT40	40	7,0 x 131	275	125	215

PROTWIST® hexagonal key

AWSH.F - PROTWIST® handle hexagonal key - spherical head - RFID

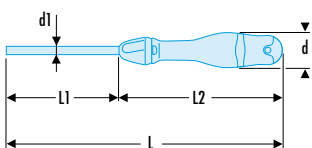

- Tool with built-in RFID chip for workshop traceability.
- Chip integration by Facom guarantees maximum detection and strength, while preserving the tool's ergonomics.
- Radio frequency identification requires appropriate storage equipment.
- Bi-material grip resists to impacts, abrasion, and chemicals.

REF	A [mm]	d [mm]	d1 x L1 [mm]	L [mm]	L2 [mm]	ΔΔ [g]
AWSH2X75FRFID	2	19	2,0 x 58	169	94	75
AWSH2.5X75FRFID	2,5	19	2,5 x 58	169	94	75
AWSH3X75FRFID	3	19	3,0 x 58	169	94	75
AWSH4X75FRFID	4	25	4,0 x 57	178	103	85
AWSH5X100FRFID	5	30	5,0 x 82	208	109	120
AWSH6X100FRFID	6	36	6,0 x 81	220	120	160
AWSH8X100FRFID	8	36	8,0 x 81	220	120	220

Screwdrivers

Insulated screwdrivers

A.VE - PROTWIST® 1,000 Volt insulated screwdrivers for slotted-head screws - RFID

Solutions FACOM.RFID



RFID

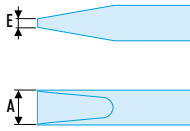

NF ISO 2380-1, NF ISO 2380-2, NF EN 60900, ISO 2380-1, ISO 2380-2, EN 60900, DIN ISO 2380-1, DIN ISO 2380-2, DIN EN 60900, ASME B107.600

- Tool with built-in RFID chip for workshop traceability.
- Chip integration by Facom guarantees maximum detection and strength, while preserving the tool's ergonomics.
- Radio frequency identification requires appropriate storage equipment.
- For your safety, each screwdriver is tested individually at 10,000 Volt for 10 seconds, at the end of the manufacturing cycle.
- 1,000 Volt sheathed round blade.
- Milled blade: --> 5.5 mm included.
- Fillet blade: 6.5 --> 12 mm.
- Bi-material grip resists to impacts, abrasion, and chemicals.

➤	A [mm]	E [mm]	d [mm]	L [mm]	L1 [mm]	L2 [mm]	L3 [mm]	ΔΔ [g]
A2X75VERFID	2,0	0,4	19	170	58	95	18	65
A2.5X75VERFID	2,5	0,4	25	178	58	103	18	75
A3X75VERFID	3,0	0,5	25	178	58	103	18	80
A3.5X100VERFID	3,5	0,6	25	204	82	104	18	85
A4X100VERFID	4,0	0,8	30	210	82	110	18	90
A5.5X125VERFID	5,5	1,0	30	235	106,5	110	18	130
A6.5X150VERFID	6,5	1,2	36	270	131	120	18	160
A8X150VERFID	8,0	1,2	40	275	131	125	18	200

AP.VE - PROTWIST® 1,000 Volt insulated screwdrivers for Phillips® head screws - RFID



RFID

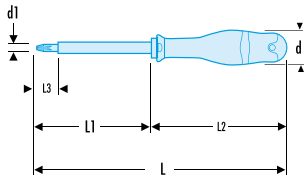

NF ISO 8764-1, NF ISO 8764-2, NF EN 60900, ISO 8764-1, ISO 8764-2, EN 60900, DIN ISO 8764-1, DIN ISO 8764-2, DIN EN 60900, ASME B107.600

- Tool with built-in RFID chip for workshop traceability.
- Chip integration by Facom guarantees maximum detection and strength, while preserving the tool's ergonomics.
- Radio frequency identification requires appropriate storage equipment.
- For your safety, each screwdriver is tested individually at 10,000 Volt for 10 seconds, at the end of the manufacturing cycle.
- 1,000 Volt sheathed round blade.
- Bi-material grip resists to impacts, abrasion, and chemicals.

➤	Phillips [No]	d [mm]	d1 [mm]	L [mm]	L1 [mm]	L2 [mm]	L3 [mm]	ΔΔ [g]
AP1X100VERFID	PH1	30	4,5	210	81,5	110	18	120
AP2X125VERFID	PH2	36	6,0	245	106	120	18	170

Hexagon keys

Screwdrivers - Keys

AD.VE - PROTWIST® 1,000 Volt insulated screwdrivers for Pozidriv® head screws - RFID

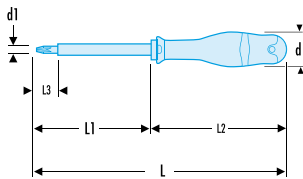

NF ISO 8764-1, NF ISO 8764-2, NF EN 60900, ISO 8764-1, ISO 8764-2, EN 60900, DIN ISO 8764-1, DIN ISO 8764-2, DIN EN 60900, ASME B107.600

- Tool with built-in RFID chip for workshop traceability.
- Chip integration by Facom guarantees maximum detection and strength, while preserving the tool's ergonomics.
- Radio frequency identification requires appropriate storage equipment.
- For your safety, each screwdriver is tested individually at 10,000 Volt for 10 seconds, at the end of the manufacturing cycle.
- 1,000 Volt sheathed round blade.
- Bi-material grip resists to impacts, abrasion, and chemicals.

RFID	Pozidriv [No]	d [mm]	d1 [mm]	L [mm]	L1 [mm]	L2 [mm]	L3 [mm]	ΔΔ [g]
AD1X100VERFID	PZ1	30	4,5	209	81,5	109	18	120
AD2X125VERFID	PZ2	36	6,0	245	106	120	18	170

86H - Hexagon keys on sleeve - RFID

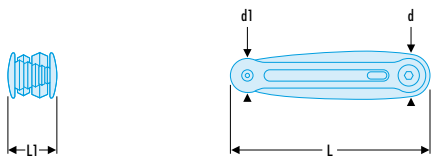

- Tool with built-in RFID chip for workshop traceability.
- Chip integration by Facom guarantees maximum detection and strength, while preserving the tool's ergonomics.
- Radio frequency identification requires appropriate storage equipment.
- Very compact sleeve.
- Positive grip.
- Keys on 90° end stop for tightening.
- Keys in silicon steel issued from series 82H.
- Finish: phosphate-coated.

RFID	⌀ [mm]	⊖ [°]	d [mm]	d1 [mm]	L [mm]	L1 [mm]	ΔΔ [g]
86H.JE7AFRFID	2,5 - 3,0 - 4,0 - 5,0 - 6,0 - 8,0 - 10,0	-	30	24	138	37	415
86H.JE7BFRFID	1,5 - 2,0 - 2,5 - 3,0 - 4,0 - 5,0 - 6,0	-	22	18	118	33	160
86H.JU6FRFID	-	5/32 - 3/16 - 7/32 - 1/4 - 5/16 - 3/8	30	24	138	37	430
86H.JU7FRFID	-	1/16 - 5/64 - 3/32 - 1/8 - 5/32 - 3/16 - 1/4	22	18	118	33	155

Pliers

Engineers pliers

High-performance multigrip plier - RFID

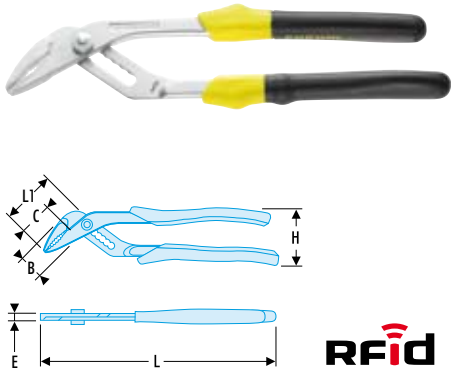

NF ISO 8976, ISO 8976, DIN ISO 8976, ASME B107.500

- Tool with built-in RFID chip for workshop traceability.
- Chip integration by Facom guarantees maximum detection and strength, while preserving the tool's ergonomics.
- Radio frequency identification requires appropriate storage equipment.
- Capacity: 44 mm.
- Ideal for confined spaces: long reach thin noses.
- Double heat-treated tips: high wear resistance, hardness 60/62 HRc.
- Finish: chrome finish, ergonomic grips.

	B [mm]	C [mm]	E [mm]	E1 [mm]	L [mm]	L1 [mm]	H [mm]	ΔΔ [g]
180.CPERFID	30	35	8	22	250	58	60	380

181A - Locking twin slip-joint multigrip pliers - RFID

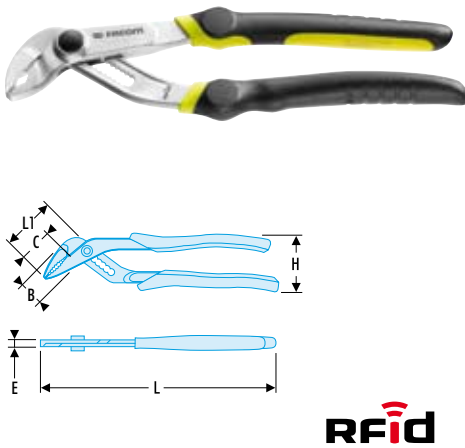

NF ISO 8976, ISO 8976, DIN ISO 8976, ASME B107.500

- Tool with built-in RFID chip for workshop traceability.
- Chip integration by Facom guarantees maximum detection and strength, while preserving the tool's ergonomics.
- Radio frequency identification requires appropriate storage equipment.
- Fast, precise push-button adjustment with safety lock.
- 12-position notches.
- The closed position of the ergonomic comfort grip handles increases the tightening power.
- High torsional strength.
- Slim-profile self-gripping nose.
- 62 HRc high-frequency treated jaws.
- Finish: chromed, bi-material ergonomic grips.

	B [mm]	C [mm]	E [mm]	E1 [mm]	L [mm]	L1 [mm]	Hex capacity [mm]	Tube capacity [mm]	H [mm]	ΔΔ [g]
181A.18CPEFID	22	24	7,5	20	185	48	36	36	52	250
181A.25CPEFID	28	28	7,5	22,5	245	54	41	42	58	380

192.CPE High-performance diagonal cutters RFID

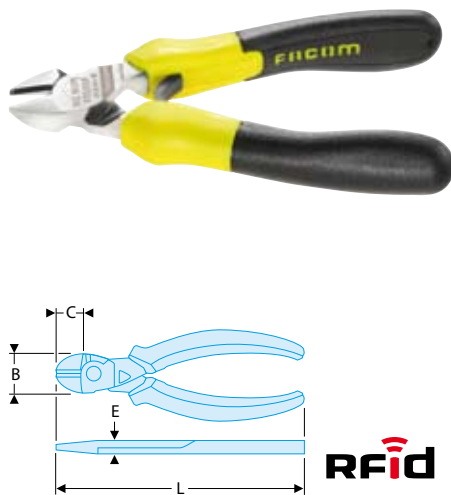

NF ISO 5749, ISO 5749, DIN ISO 5749, ASME B107.500

- Tool with built-in RFID chip for workshop traceability.
- Chip integration by Facom guarantees maximum detection and strength, while preserving the tool's ergonomics.
- Radio frequency identification requires appropriate storage equipment.
- Cutting edges designed to cleanly cut all types of wire: piano wire, soft wires and modern materials 200 kg/mm².
- Minimum cutting force thanks to long lever arm and offset axis.
- High durability Chrome-Molybdenum-Vanadium steel, very hard cutting edges 61/63 HRc.
- Ergonomic grips resistant to chemical agents.
- Removable return spring.
- Finish: chromed.

	B [mm]	C [mm]	d maxi [mm]	E [mm]	L [mm]	ΔΔ [g]
192.16CPEFID	24,0	180	1,6	10,0	160	220
192.20CPEFID	28,0	22,0	2,0	11,5	200	340

Pliers

Pliers

Electricians diagonal cutter - RFID

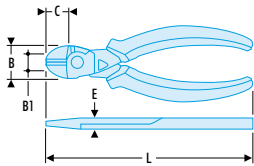

NF ISO 5749, ISO 5749, DIN ISO 5749, ASME B107.500

- Tool with built-in RFID chip for workshop traceability.
- Chip integration by Facom guarantees maximum detection and strength, while preserving the tool's ergonomics.
- Radio frequency identification requires appropriate storage equipment.
- Snipe nose for confined space (electrical cabinets, wiring).
- Semi-flush cutting edges, designed to cleanly cut through all types of wire: hard wires (max. 160 Kg/mm²), thin copper wires, modern materials.
- Long lever arm, offset pivot for minimum cutting effort.
- High durability Chrome-Molybdenum-Vanadium steel, very hard cutting edges 61/63 HRC.
- Ergonomic grips resistant to chemical agents.
- Removable return spring.
- Finish: chromed.

	B [mm]	C [mm]	E [mm]	L [mm]	ΔΔ [g]
391.16CPE RFID	19	21	9	165	210

190.CPE - High-performance end cutter - RFID

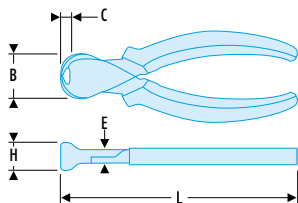

NF ISO 5748, ISO 5748, DIN ISO 5748, ASME B107.500

- Tool with built-in RFID chip for workshop traceability.
- Chip integration by Facom guarantees maximum detection and strength, while preserving the tool's ergonomics.
- Radio frequency identification requires appropriate storage equipment.
- Snipe nose for confined space (electrical cabinets, wiring).
- Semi-flush cutting edges, designed to cleanly cut through all types of wire: hard wires (max. 160 Kg/mm²), thin copper wires, modern materials.
- Long lever arm, offset pivot for minimum cutting effort.
- High durability Chrome-Molybdenum-Vanadium steel, very hard cutting edges 61/63 HRC.
- Ergonomic grips resistant to chemical agents.
- Removable return spring.
- Finish: chromed.

	B [mm]	C [mm]	d maxi [mm]	E [mm]	L [mm]	ΔΔ [g]
190.16CPE RFID	28	6,5	1,6	11,5	160	220
190.20CPE RFID	31	7,5	2,0	13,5	200	360

185-195.CPE - Long half-round nose pliers - RFID

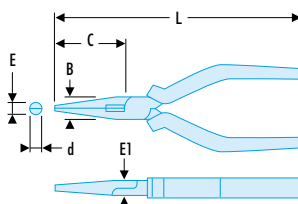

NF ISO 5745, ISO 5745, DIN ISO 5745, ASME B107.500

- Tool with built-in RFID chip for workshop traceability.
- Chip integration by Facom guarantees maximum detection and strength, while preserving the tool's ergonomics.
- Radio frequency identification requires appropriate storage equipment.
- Narrow, finely serrated tips with a pipe-grip.
- Side cutter for copper and hard steel wire (max. 160 kg/mm²).
- 185: straight nose.
- 195: 40° angled nose.
- Ergonomic grips resistant to chemical agents.
- Removable return spring.
- Finish: chromed.

	B [mm]	C [mm]	d [mm]	E [mm]	E1 [mm]	L [mm]	ΔΔ [g]
185.20CPE RFID	18	75	2,9	3,6	9	200	215
195.20CPE RFID	18	69	2,9	3,6	9	200	215



RFID



RFID



RFID



RFID



RFID



RFID



FLUO



FLUO



FLUO



FLUO



FLUO

Pliers

193-195.CPE - Short half-round nose pliers - RFID

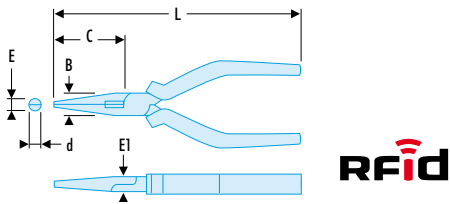

NF ISO 5745, ISO 5745, DIN ISO 5745, ASME B107.500

- Tool with built-in RFID chip for workshop traceability.
- Chip integration by Facom guarantees maximum detection and strength, while preserving the tool's ergonomics.
- Radio frequency identification requires appropriate storage equipment.
- Narrow, finely serrated tips.
- Side cutter for copper and hard steel wire (max. 160 kg/mm²).
- Ergonomic grips resistant to chemical agents.
- Removable return spring.
- Finish: chromed.

Ref	B [mm]	C [mm]	d [mm]	E [mm]	E1 [mm]	L [mm]	ΔΔ [g]
193.16CPE	17	50	2,5	3	9	160	200
195.16CPE	17	50	2,5	3	9	160	200

187.CPE - Combination pliers - RFID

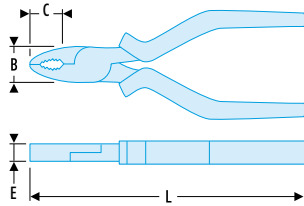

NF ISO 5746, ISO 5746, DIN ISO 5746, ASME B107.500

- Tool with built-in RFID chip for workshop traceability.
- Chip integration by Facom guarantees maximum detection and strength, while preserving the tool's ergonomics.
- Radio frequency identification requires appropriate storage equipment.
- Cutting edges designed to cut all types of wire: piano wire, soft wires and modern materials (Fe 200 kg/mm²).
- Long lever arm, offset pivot for minimum cutting effort.
- High durability Chrome-Molybdenum-Vanadium steel, very hard cutting edges 61/63 HRc.
- Ergonomic grips resistant to chemical agents.
- Removable return spring.
- Finish: chromed.

Ref	B [mm]	C [mm]	E [mm]	L [mm]	ΔΔ [g]
187.16CPE	21	34	9,5	165	215
187.18CPE	23	36	10,0	185	245

Pliers

Pliers

188 - Flat nose pliers - RFID

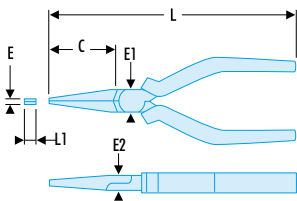

NF ISO 5745, ISO 5745, DIN ISO 5745, ASME B107.500

- Tool with built-in RFID chip for workshop traceability.
- Chip integration by Facom guarantees maximum detection and strength, while preserving the tool's ergonomics.
- Radio frequency identification requires appropriate storage equipment.
- Serrated nose for a firm grip.
- 188.E: snipe nose version for confined spaces.
- Ergonomic grips resistant to chemical agents.
- Removable return spring.
- Finish: chromed.

RFID	C [mm]	E [mm]	E1 [mm]	E2 [mm]	L [mm]	L1 [mm]	ΔΔ [g]
188.16CPRFID	46	4	18	9	168	6,5	160
188.20CPRFID	75	4	18	9	200	6,5	220



Micro-Tech® cutting pliers

Micro-Tech® "heavy-duty" cutters - RFID

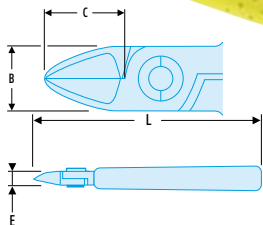

NF ISO 9654, ISO 9654, DIN ISO 9654, ASME B107.500

- Tool with built-in RFID chip for workshop traceability.
- Chip integration by Facom guarantees maximum detection and strength, while preserving the tool's ergonomics.
- Radio frequency identification requires appropriate storage equipment.
- Pliers for clear cutting multiple materials: from copper wire to piano wire up to 0.5 mm.

RFID	B [mm]	C [mm]	E [mm]	L [mm]	Cu - Ni Ø [mm]	Fe 30 HRc diam. [mm]	Coupe	ΔΔ [g]
405.10MTFRFID	10,5	11,5	7	110	0,3 - 1,4	0,8	∧	80
405.12MTFRFID	16	16	8	125	0,4 - 2,0	1,0	∧	115



Micro-Tech® "long" cutters: access - RFID

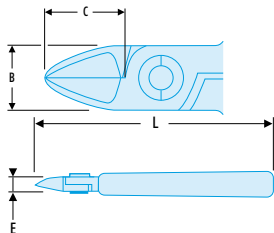

NF ISO 9654, ISO 9654, DIN ISO 9654, ASME B107.500

- Tool with built-in RFID chip for workshop traceability.
- Chip integration by Facom guarantees maximum detection and strength, while preserving the tool's ergonomics.
- Radio frequency identification requires appropriate storage equipment.
- These pliers allow to go further; up to + 1.5 to 2 mm compared with standard pliers.
- Fall prevention models avoid wire ejection.

RFID	B [mm]	C [mm]	E [mm]	L [mm]	Cu - Ni Ø [mm]	Coupe	ΔΔ [g]
425FRFID	10,5	13	7	110	0,1 - 1,3	┌	80



Pliers

Micro-Tech® grippers

Micro-Tech® long and rigid nose gripper - RFID

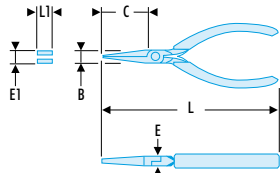

NF ISO 9655, ISO 9655, DIN ISO 9655, ASME B107.500

- Tool with built-in RFID chip for workshop traceability.
- Chip integration by Facom guarantees maximum detection and strength, while preserving the tool's ergonomics.
- Radio frequency identification requires appropriate storage equipment.

	B [mm]	C [mm]	E [mm]	E1 [mm]	L [mm]	L1 [mm]	ΔΔ [g]
421.MTFRFID	11	33	7	1	130	5	90

Micro-Tech® thin nose gripper - RFID

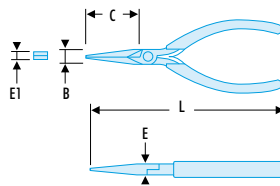

NF ISO 9655, ISO 9655, DIN ISO 9655, ASME B107.500

- Tool with built-in RFID chip for workshop traceability.
- Chip integration by Facom guarantees maximum detection and strength, while preserving the tool's ergonomics.
- Radio frequency identification requires appropriate storage equipment.
- Narrow mesh, for high precision works.

	B [mm]	C [mm]	E [mm]	E1 [mm]	L [mm]	ΔΔ [g]
431.LMTFRFID	9	35	6	1	135	100

Micro-Tech® long and rigid nose gripper - RFID

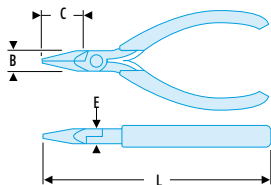

NF ISO 9655, ISO 9655, DIN ISO 9655, ASME B107.500

- Tool with built-in RFID chip for workshop traceability.
- Chip integration by Facom guarantees maximum detection and strength, while preserving the tool's ergonomics.
- Radio frequency identification requires appropriate storage equipment.
- Long and strong nose for precision and extra power works.

	B [mm]	C [mm]	E [mm]	E1 [mm]	L [mm]	ΔΔ [g]
422.MTFRFID	11	33	7	0,5	130	110

Pliers

Pliers

Micro-Tech® gripping plier with fluorescent grips - RFID

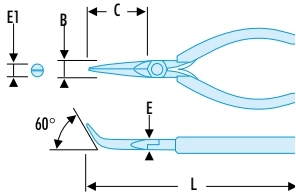

NF ISO 9655, ISO 9655, DIN ISO 9655, ASME B107.500

- Tool with built-in RFID chip for workshop traceability.
- Chip integration by Facom guarantees maximum detection and strength, while preserving the tool's ergonomics.
- Radio frequency identification requires appropriate storage equipment.
- Detect the tool thanks to its fluorescence, activated by a lamp or UV neon light.
- Rigid jaws, angled 60°.

	B [mm]	C [mm]	E [mm]	E1 [mm]	L [mm]	ΔΔ [g]
423.MTRFRID	11	25	7	1,4	125	90

Micro-Tech® 45° angled thin nose gripper - RFID

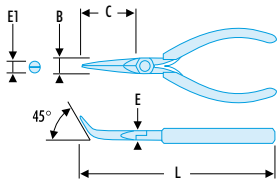

NF ISO 9655, ISO 9655, DIN ISO 9655, ASME B107.500

- Tool with built-in RFID chip for workshop traceability.
- Chip integration by Facom guarantees maximum detection and strength, while preserving the tool's ergonomics.
- Radio frequency identification requires appropriate storage equipment.
- Fine mesh, for high precision works.

	B [mm]	C [mm]	E [mm]	E1 [mm]	L [mm]
433.LMTRFRID	9	35	6	1,6	135

Crimping plier

449BFRFID Standard crimping plier for insulated terminals - RFID



- Tool with built-in RFID chip for workshop traceability.
 - Chip integration by Facom guarantees maximum detection and strength, while preserving the tool's ergonomics.
 - Radio frequency identification requires appropriate storage equipment.
 - Crimping pre-insulated terminals: 1.5-2.5-6 mm².
 - Crimping bare terminals: 1.5-2.5-6 mm².
 - Stripping: 0.75 to 6 mm².
 - Built-in wire cutting function.
- Weight: 340 g.



RFID



RFID



RFID



RFID



RFID



RFID



FLUO



FLUO



FLUO



FLUO



FLUO

Pliers

1,000 Volts insulated pliers VE series

180 - 1,000 Volt insulated multigrip plier - RFID

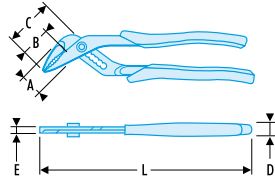
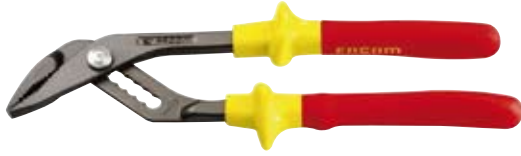

NF ISO 8976, ISO 8976, DIN ISO 8976, ASME B107.500

- Tool with built-in RFID chip for workshop traceability.
- Chip integration by Facom guarantees maximum detection and strength, while preserving the tool's ergonomics.
- Radio frequency identification requires appropriate storage equipment.
- Capacity: 44 mm.
- Ideal for confined spaces: long reach thin noses.
- Double heat-treated tips: high wear resistance, hardness 60/62 HRC.
- Varnish finish, ergonomic grips.

	A [mm]	B [mm]	C [mm]	E [mm]	E1 [mm]	L [mm]	ΔΔ [g]
180.VERFID	30	35	58	8	22	250	380

1,000 Volt insulated electricians diagonal cutter - RFID

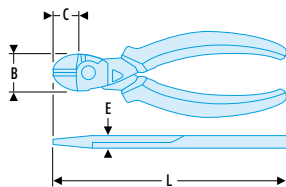

NF ISO 5749, NF EN 60900, ISO 5749, EN 60900, DIN ISO 5749, DIN EN 60900, ASME B107.500

- Tool with built-in RFID chip for workshop traceability.
- Chip integration by Facom guarantees maximum detection and strength, while preserving the tool's ergonomics.
- Radio frequency identification requires appropriate storage equipment.
- For your safety, all pliers are tested individually at 10,000 Volt for 10 seconds, at the end of the manufacturing cycle.
- Slim head for confined access (electric cabinets, wiring works, etc.).
- Semi-flush cutting edges to cleanly cut through all types of wire: hard wire, thin copper wires, modern materials, etc.
- Minimum cutting force thanks to long lever arm and offset axis.
- High durability thanks to Chrome-Molybdenum-Vanadium steel (hard cutting edges: 61/63 HRC).
- Removable return spring.
- Ergonomic anti-slip grips.
- Finish: polished, varnished.

	B [mm]	C [mm]	E [mm]	L [mm]	160kg /mm ² (Ømm)	Cu max Ø/mm ² (Ømm)	ΔΔ [g]
391.16VERFID	19	21	9	165	1,6	0,7 - 3,5	210

185-195.VE - 1,000 Volt insulated long half-round nose pliers - RFID

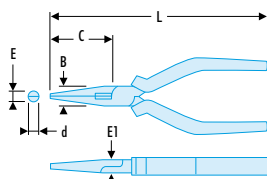

NF ISO 5745, NF EN 60900, ISO 5745, EN 60900, DIN ISO 5745, DIN EN 60900, ASME B107.500

- Tool with built-in RFID chip for workshop traceability.
- Chip integration by Facom guarantees maximum detection and strength, while preserving the tool's ergonomics.
- Radio frequency identification requires appropriate storage equipment.
- For your safety, all pliers are tested individually at 10,000 Volt for 10 seconds, at the end of the manufacturing cycle.
- Slim, fine serrated noses. - 185.VE: straight nose. - 195.VE: 40° angled nose.
- Lateral wire cutter for copper and hard steel wire.
- Removable return spring.
- Ergonomic anti-slip grips.
- Finish: polished, varnished.

	B [mm]	C [mm]	d [mm]	E [mm]	E1 [mm]	L [mm]	160kg /mm ² (Ømm)	Cu max Ø/mm ² (Ømm)	ΔΔ [g]
185.20VERFID	18	75	2,9	3,6	9	200	1,6	0,7 - 3,5	215
195.20VERFID	18	69	2,9	3,6	9	200	1,6	0,7 - 3,5	215

Pliers

Pliers

1,000 Volt insulated short half-round nose plier - RFID

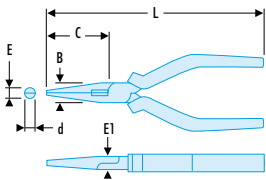

NF ISO 5745, NF EN 60900, ISO 5745, EN 60900, DIN ISO 5745, DIN EN 60900, ASME B107.500

- Tool with built-in RFID chip for workshop traceability.
- Chip integration by Facom guarantees maximum detection and strength, while preserving the tool's ergonomics.
- Radio frequency identification requires appropriate storage equipment.
- For your safety, all pliers are tested individually at 10,000 Volt for 10 seconds, at the end of the manufacturing cycle.
- Slim, straight, fine serrated noses.
- Lateral wire cutter for copper and hard steel wire.
- Removable return spring.
- Ergonomic anti-slip grips.
- Finish: polished, varnished.

	B [mm]	C [mm]	d [mm]	E [mm]	E1 [mm]	L [mm]	160kg/mm ² [Ømm]	Cu max Ø/ mm ² [Ømm]	ΔΔ [g]
193.16VERFID	17	50	2,5	3	9	160	1,6	0,7 - 3,0	200

1,000 Volt insulated combination plier - RFID

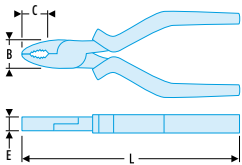

NF ISO 5746, NF EN 60900, ISO 5746, EN 60900, DIN ISO 5746, DIN EN 60900, ASME B107.500

- Tool with built-in RFID chip for workshop traceability.
- Chip integration by Facom guarantees maximum detection and strength, while preserving the tool's ergonomics.
- Radio frequency identification requires appropriate storage equipment.
- For your safety, all pliers are tested individually at 10,000 Volt for 10 seconds, at the end of the manufacturing cycle.
- Cutting edges designed to cut through all types of wire: piano wire, soft wires, modern materials, etc.
- Minimum cutting force thanks to long lever arm and offset axis.
- High durability thanks to Chrome-Molybdenum-Vanadium steel (hard cutting edges: 61/63 HRC).
- Removable return spring.
- Ergonomic anti-slip grips.
- Finish: polished, varnished.

	B [mm]	C [mm]	E [mm]	L [mm]	200kg/mm ² [Ømm]	ΔΔ [g]
187.18VERFID	23	36	10,0	185	1,8	245

1,000 Volt insulated flat nose plier - RFID

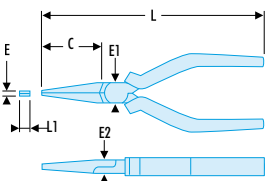

NF ISO 5745, NF EN 60900, ISO 5745, EN 60900, DIN ISO 5745, DIN EN 60900, ASME B107.500

- Tool with built-in RFID chip for workshop traceability.
- Chip integration by Facom guarantees maximum detection and strength, while preserving the tool's ergonomics.
- Radio frequency identification requires appropriate storage equipment.
- For your safety, all pliers are tested individually at 10,000 Volt for 10 seconds, at the end of the manufacturing cycle.
- Serrated nose for stronger grip.
- Removable return spring.
- Ergonomic anti-slip grips.
- Finish: polished, varnished.

	C [mm]	E [mm]	E1 [mm]	E2 [mm]	L [mm]	L1 [mm]	ΔΔ [g]
188.20VERFID	75	4	18	9	200	6,5	220



Pliers

1,000 Volt insulated stripper - RFID

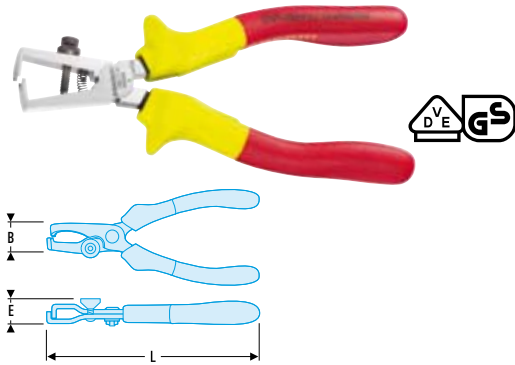

RFID

NF EN 60900, EN 60900, DIN EN 60900

- Tool with built-in RFID chip for workshop traceability.
- Chip integration by Facom guarantees maximum detection and strength, while preserving the tool's ergonomics.
- Radio frequency identification requires appropriate storage equipment.
- For your safety, all pliers are tested individually at 10,000 Volt for 10 seconds, at the end of the manufacturing cycle.
- For multiple or single strand wires 0.5 --> 6 mm².
- Adjustment screw with lock nut.
- Metal return screw.
- Ergonomic anti-slip grips.
- Finish: polished, varnished.

RFID	B [mm]	E [mm]	L [mm]	ΔΔ [g]
194.17VERFID	17	8,5	170	205

Circlip® pliers

179A - Straight nose inside circlip® pliers - RFID



RFID

NF E 73-130, DIN 5256, ASME B107.500

- Tool with built-in RFID chip for workshop traceability.
- Chip integration by Facom guarantees maximum detection and strength, while preserving the tool's ergonomics.
- Radio frequency identification requires appropriate storage equipment.
- For inside Circlips® 8 --> 100 mm.
- Piano wire tips: high distortion resistance.
- Long 10° angled tips for optimum circlip holding.
- Identification colour code: saves time.
- Grips in anti-slip granite PVC.

RFID	d [mm]	d mini - maxi [mm]	L [mm]	ΔΔ [g]
179A.9RFID	0,9	8 - 13	140	135
179A.13RFID	1,3	12 - 25	140	135
179A.18RFID	1,8	19 - 60	185	235
179A.23RFID	2,2	40 - 100	215	320

199A - 90° angled nose inside circlip® pliers - RFID



RFID

NF E 73-130, DIN 5256, ASME B107.500

- Tool with built-in RFID chip for workshop traceability.
- Chip integration by Facom guarantees maximum detection and strength, while preserving the tool's ergonomics.
- Radio frequency identification requires appropriate storage equipment.
- For inside Circlips® 8 --> 100 mm.
- Piano wire tips: high distortion resistance.
- Long 10° angled tips for optimum circlip holding.
- Identification colour code: saves time.
- Grips in anti-slip granite PVC.

RFID	d [mm]	d mini - maxi [mm]	L [mm]	ΔΔ [g]
199A.9RFID	0,9	8 - 13	130	135
199A.13RFID	1,3	12 - 25	130	135
199A.18RFID	1,8	19 - 60	170	235
199A.23RFID	2,2	40 - 100	205	320

Pliers

Pliers

177A - Straight nose outside circlip® pliers - RFID



NF E 73-130, DIN 5254, ASME B107.500

- Tool with built-in RFID chip for workshop traceability.
- Chip integration by Facom guarantees maximum detection and strength, while preserving the tool's ergonomics.
- Radio frequency identification requires appropriate storage equipment.
- For outside Circlips® 3 --> 100 mm.
- Piano wire tips: high distortion resistance.
- Long 10° angled tips for optimum circlip holding.
- Identification colour code: saves time.
- Grips in anti-slip granite PVC.

RFID	d [mm]	d mini - maxi [mm]	L [mm]	ΔΔ [g]
177A.9RFID	0,9	3 - 10	150	125
177A.13RFID	1,3	10 - 25	150	125
177A.18RFID	1,8	19 - 60	180	195
177A.23RFID	2,2	40 - 100	215	300

197A - 90° angled nose outside circlip® pliers - RFID



NF E 73-130, DIN 5254, ASME B107.500

- Tool with built-in RFID chip for workshop traceability.
- Chip integration by Facom guarantees maximum detection and strength, while preserving the tool's ergonomics.
- Radio frequency identification requires appropriate storage equipment.
- For outside Circlips® 3 --> 100 mm.
- Piano wire tips: high distortion resistance.
- Long 10° angled tips for optimum circlip holding.
- Identification colour code: saves time.
- Grips in anti-slip granite PVC.

RFID	d [mm]	d mini - maxi [mm]	L [mm]	ΔΔ [g]
197A.9RFID	0,9	3 - 10	140	125
197A.13RFID	1,3	10 - 25	140	125
197A.18RFID	1,8	19 - 60	170	195
197A.23RFID	2,2	40 - 100	200	300

Lock-grip pliers

500F - Short-nose lock-grip plier - RFID

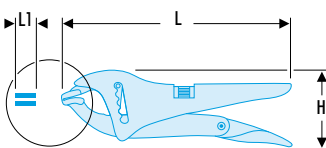

ASME B107.500

- Tool with built-in RFID chip for workshop traceability.
- Chip integration by Facom guarantees maximum detection and strength, while preserving the tool's ergonomics.
- Radio frequency identification requires appropriate storage equipment.
- 4-position slip joint system.
- Nose width 17 mm.
- Machined groove in upper jaw holds small round sections.
- Finish: chromed.

RFID	H [mm]	L [mm]	L1 [mm]	ΔΔ [g]
500FRFID	58	225	17	570

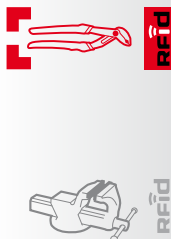

Lock-grip pliers - Locking-wire pliers

Long nose lock-grip plier - RFID

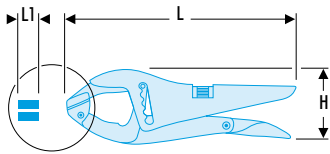

ASME B107.500

- Tool with built-in RFID chip for workshop traceability.
- Chip integration by Facom guarantees maximum detection and strength, while preserving the tool's ergonomics.
- Radio frequency identification requires appropriate storage equipment.
- 4-position slip joint system.
- Nose width 17 mm.
- Machined groove in upper jaw holds small round sections.
- Finish: chromed.

	H [mm]	L [mm]	L1 [mm]	ΔΔ [g]
501RRFID	63	250	17	650

Locking-wire pliers

FACOM LOCKING-WIRE PLIERS

Fast twist in lock-wire securing assemblies subject to vibration.

- For stainless and Inconel wire Ø 1 mm.
- Side wire cutter.
- Slim nose-tip for optimum manoeuvrability.
- 8" model: 2.5 turns, 95 mm travel.
- 10" model: 3 turns, 125 mm travel.

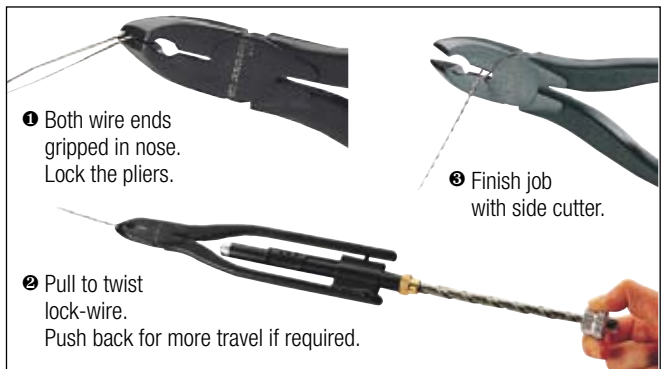
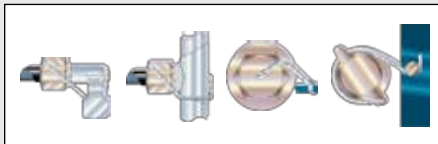

Automatic model

- Automatic-reset model for simplicity and time-saving.

445 - Locking-wire pliers 8 and 10" - RFID

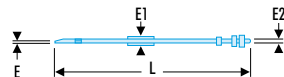
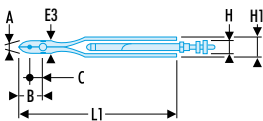

ASME B107.500

- Tool with built-in RFID chip for workshop traceability.
- Chip integration by Facom guarantees maximum detection and strength, while preserving the tool's ergonomics.
- Radio frequency identification requires appropriate storage equipment.
- "Automatic" model.
- Side wire-cutter: stainless steel diameter 1 mm.
- 445.8RRFID = 2.5 turns: 95 mm length.
- 445.10RRFID = 3 turns: 125 mm length.
- Finish: phosphate-coated.

	A [mm]	B [mm]	C [mm]	E [mm]	E1 [mm]	E2 [mm]	E3 [mm]	H [mm]	H1 [mm]	L [mm]	L1 [mm]	ΔΔ [g]
445.8RRFID	3	20	7	2,5	15	10,5	15	22	37	215	170	265
445.10RRFID	3	30	11	2,5	15,5	11,5	19	25	40	360	230	420

Measuring

Measuring - Hammers - Cutting

Stainless steel rule - 2 sides - RFID

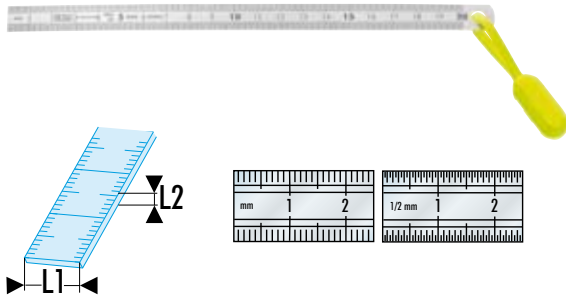

- Tool with built-in RFID chip for workshop traceability.
- Chip integration by Facom guarantees maximum detection and strength, while preserving the tool's ergonomics.
- Radio frequency identification requires appropriate storage equipment.
- Engraved on both sides.
- One edge in mm - One edge in 1/2 mm.
- Stainless steel 18 % Cr - 8 % Ni.
- Anti-reflection treatment.
- Class II as per regulations applies to rules with a length above or equal to 500 mm.

DELTA.1051.03RFID	L [mm]	L1 x L2 [mm]	ΔΔ [g]
	200	13 x 0,5	45

ABS body tape measure - RFID



- Tool with built-in RFID chip for workshop traceability.
- Chip integration by Facom guarantees maximum detection and strength, while preserving the tool's ergonomics.
- Radio frequency identification requires appropriate storage equipment.
- Ergonomic, ABS material.
- Tape with mat anti-reflection nylon tape.
- High strength tape.
- High strength cover hook:
 - 2 rivets with stainless reinforcement plate on the 2 and 3 m.
 - 3 rivets with stainless reinforcement plate on the 5 and 8 m.
- Interior measurements by adding the L dimension (see table).

893.316FLUORFID	E [mm]	H [mm]	L [mm]	L1 [mm]	L2 [m]	ΔΔ [g]
	27	60	60	16	3	160

PRODUCTIVITY AND SAFETY

RFID
TECHNOLOGY
BY FACOM

CribMaster
Inventory Management System



For further information on RFID technology, scan this QR code with your smartphone or your tablet.



www.facom.com

Hammer

Solutions **FACOM.RFid**

200H - Graphite handle riveting engineers hammer - RFID



RFid

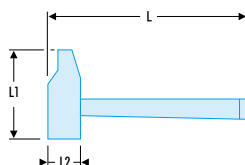

NF E 71-016, NF ISO 15601, ISO 15601

- Tool with built-in RFID chip for workshop traceability.
- Chip integration by Facom guarantees maximum detection and strength, while preserving the tool's ergonomics.
- Radio frequency identification requires appropriate storage equipment.
- High security Hickery handle.
- Triple wedge design - 1 wooden and 2 metal wedges.

RFID	L [mm]	L1 [mm]	L2 [mm]	$\Delta\Delta$ [kg]
200H.26RFID	245	80	25	0,345
200H.30RFID	270	93	30	0,470
200H.32RFID	300	100	32	0,585
200H.40RFID	330	108	40	1,025
200H.60RFID	380	151	60	2,800

205H - Graphite handle DIN engineers hammer - RFID



RFid

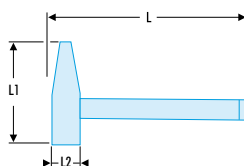

NF ISO 15601, ISO 15601, DIN 1041

- Tool with built-in RFID chip for workshop traceability.
- Chip integration by Facom guarantees maximum detection and strength, while preserving the tool's ergonomics.
- Radio frequency identification requires appropriate storage equipment.
- High security Hickery handle.
- Triple wedge design - 1 wooden and 2 metal wedges.

RFID	L [mm]	L1 [mm]	L2 [mm]	$\Delta\Delta$ [kg]
205H.20RFID	280	96	19	0,250
205H.30RFID	300	106	23	0,380
205H.50RFID	320	122	27	0,580
205H.80RFID	350	132	33	0,960
205H.100RFID	360	137	36	1,140

249 - Standard drift punches - RFID

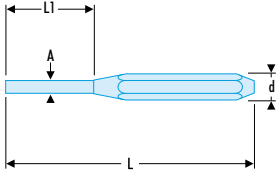
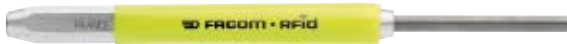

RFID

NF E 71-211, DIN 6450, ASME B107.410

- Tool with built-in RFID chip for workshop traceability.
- Chip integration by Facom guarantees maximum detection and strength, while preserving the tool's ergonomics.
- Radio frequency identification requires appropriate storage equipment.
- Hexagonal shank, high-strength steel tip, hardened to 53-58 HRC.
- Zinc-plated finish.

RFID	A [mm]	d [mm]	L [mm]	L1 [mm]	ΔΔ [g]
249.2RFID	1,9	10	115	30	40
249.3RFID	2,9	10	125	40	45
249.4RFID	3,9	12	150	50	75
249.5RFID	4,9	12	165	50	85
249.6RFID	5,9	14	180	50	130
249.8RFID	7,9	14	200	50	170
249.10RFID	9,9	18	200	50	230

256 - Precision centre punches - RFID

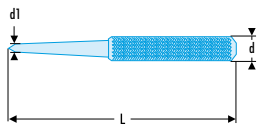

RFID

NF E 71-211, DIN 7250, ASME B107.410

- Tool with built-in RFID chip for workshop traceability.
- Chip integration by Facom guarantees maximum detection and strength, while preserving the tool's ergonomics.
- Radio frequency identification requires appropriate storage equipment.
- Chrome-vanadium steel forged, hardened to 52 to 58 HRc.
- Presentation: knurled body.
- Zinc-plated finish.

RFID	d1 [mm]	d [mm]	L [mm]	ΔΔ [g]
256.4RFID	4	10	105	35
256.6RFID	6	12	115	55
256.8RFID	8	14	130	80



RFID



RFID



RFID



RFID



RFID



RFID



FLUO



FLUO



FLUO



FLUO



FLUO

Maintenance - Cutting

Pipe wrenches

131A - Steel Stillson models - RFID

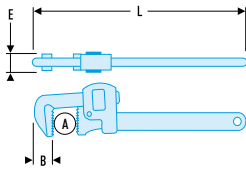

- Tool with built-in RFID chip for workshop traceability.
- Chip integration by Facom guarantees maximum detection and strength, while preserving the tool's ergonomics.
- Radio frequency identification requires appropriate storage equipment.
- Capacity: 0 to 102 mm; 0 to 3"1/2.
- Very robust wrench, head hardened to 55 HRc.
- Accurate approach thanks to fine machining of the threads and button, good grip.

RFID	A maxi [mm]	A maxi ["]	B [mm]	E [mm]	L [mm]	L ["]	ΔΔ [kg]
131A.8RFID	27	3/4	19,5	12,5	200	8	0,3
131A.10RFID	34	1	25,0	16,0	250	10	0,62
131A.14RFID	49	1 1/2	29,5	21,0	350	14	1,08
131A.18RFID	60	2	32,0	24,0	450	18	1,82
131A.24RFID	76	2 1/2	41,5	27,5	600	24	3,02

Scie

603FRFID "High performance" hacksaw frame - RFID



NF E 73-073, DIN 6473

- Tool with built-in RFID chip for workshop traceability.
 - Chip integration by Facom guarantees maximum detection and strength, while preserving the tool's ergonomics.
 - Radio frequency identification requires appropriate storage equipment.
 - Optimum and durable automatic blade tension control at 110 kg.
 - Aluminium bow for maximum stiffness.
 - Ergonomic handle for maximum cutting comfort.
 - 8 blade positions.
 - Ultra-fast blade changing.
 - Takes 300 mm blade.
 - Dimensions (L. x W.): 440 x 145 mm.
 - Supplied with one blade.
- Weight: 850 g.

- Spare blades: 668B.

Knife

18 mm automatically reloading utility knife - RFID

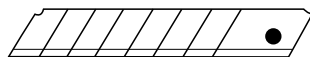
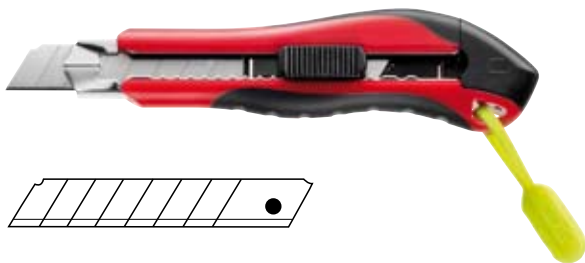

- Tool with built-in RFID chip for workshop traceability.
- Chip integration by Facom guarantees maximum detection and strength, while preserving the tool's ergonomics.
- Radio frequency identification requires appropriate storage equipment.
- Productivity, accessibility, safety.
- Automatically reloading snap-off blades.
- Ergonomic soft ABS handle.
- Stainless steel blade guide.
- Blade lock knob.
- 6-blade cartridge.
- Integral blade snapper.

RFID	E maxi [mm]	H [mm]	L [mm]	ΔΔ [g]
844.S18RFID	24	47	172	190

▣ Safety knife with retractable blade - RFID

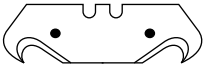
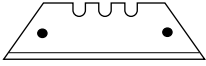

RFID

- Tool with built-in RFID chip for workshop traceability.
- Chip integration by Facom guarantees maximum detection and strength, while preserving the tool's ergonomics.
- Radio frequency identification requires appropriate storage equipment.
- Safety knife.
- Blade automatically retracts after use.
- Zamak body.
- ABS cursor, front or side thumb control.
- Supplied with 3 blades (1 factory-mounted and 2 in the body).

RFID	E maxi [mm]	H mini - maxi [mm]	L [mm]	ΔΔ [g]
844.DRFID	27	40,5 - 44,0	176	215

▣ 840.F Lock-back knife with bi-material handle - RFID



RFID

- Tool with built-in RFID chip for workshop traceability.
 - Chip integration by Facom guarantees maximum detection and strength, while preserving the tool's ergonomics.
 - Radio frequency identification requires appropriate storage equipment.
 - Blade in polished stainless steel. Blade partially smooth for accurate cutting and another serrated for powerful cutting.
 - Quick one-handed opening.
 - Knife at the tip of the knife: window breaker function.
 - Safe: lock-back.
 - Universal hanging hook.
 - Clip at the back of the knife for direct hanging to the belt.
 - Blade length 77 mm; closed length: 115 mm.
 - Total length: 186 mm.
 - Supplied in vertical nylon case which fastens to the belt.
- Weight: 200 g.

▣ 640180 Twin-blade electricians knife with plastic handle - RFID



RFID

- Tool with built-in RFID chip for workshop traceability.
 - Chip integration by Facom guarantees maximum detection and strength, while preserving the tool's ergonomics.
 - Radio frequency identification requires appropriate storage equipment.
 - Electricians knife with blades suitable for cable work:
 - 1 straight hollow ground general-purpose blade (length: 65 mm).
 - 1 short curved blade, specially designed for cable work (length: 35 mm).
 - Safe: lock-back for each blade.
 - Length closed: 104 mm.
 - Total length: 131/169 mm.
- Weight: 130g.



RFID



RFID



RFID



RFID



RFID



RFID



FLUO



FLUO



FLUO



FLUO



FLUO



NEW FLUORESCENT TOOL RANGE



Your solution for "DARK OR DIMLY LIT AREAS"



SAFETY

- High-visibility colour code ensuring easy detection, even in broad daylight.
- Better tool visibility, particularly in dark areas: less accidents, injuries, incidents...
- No chipping due to impacts, no product elements or accessories lost...

IMPROVED PRODUCTIVITY

- Tools compatible with rolling cabinet organiser modules.
- Faster recovery of lost tools.
- Easy cleaning.

ERGONOMICS

- Same dimensions as standard tools.
- Good product grip.



COST REDUCTION

- No more lost tools to be replaced
- Durability identical to standard tools.

FLUO



A comprehensive product range for most common applications. Wrenches, ratchets, sockets, gauges, pliers, hammers, rules, etc.



• Solutions **FACOM.FLUO**



Combination wrenches - FLUO

Fixed and variable opening wrenches

440F - Metric combination wrenches - FLUO

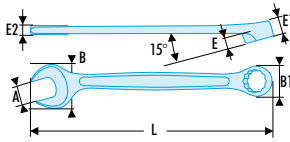

FLUO

NF ISO 691, NF ISO 7738, NF ISO 3318, NF ISO 1711-1, E74-306, ISO 691, ISO 7738, ISO 3318, ISO 1711-1, DIN ISO 691, DIN ISO 1711-1, DIN 3113, ASME B107.100

- Fluorescent tool, detectable by ultraviolet light. Detectable in dark and dimly lit areas for 3 metres.
- Standard wrench for all current applications.
- High mechanical strength combined with compact size meeting aeronautical standards.
- Ring head:
 - Ring open end (size E) designed for better access to series or embedded screws.
 - OGV® profile with 12-point ring for powerful tightening while protecting the nut.
 - H suffix = 6-point ring.
 - Ring head angled at 15°.
- Open end head:
 - Open end angled at 15°.
 - Open end head-handle geometry optimised for increased access.
- Metric sizes: 4 to 19 mm.
- Presentation: satin chrome finish.

⊞	A [mm]	B [mm]	B1 [mm]	E [mm]	E1 [mm]	E2 [mm]	L [mm]	ΔΔ [g]
440.4HF	4	10,0	7,8	2,1	3,5	3,0	106	10
440.5HF	5	13,3	9,2	3,1	6,0	3,6	115	16
440.5,5HF	5,5	13,3	9,2	3,1	6,0	3,8	115	15
440.6F	6	14,1	10,0	3,1	6,0	3,8	115	20
440.7F	7	17,2	11,2	3,4	6,2	3,9	122	20
440.8F	8	19,2	12,8	3,5	6,7	4,7	133	30
440.9F	9	21,2	14,2	3,9	7,1	4,7	138	35
440.10F	10	23,0	15,0	4,2	7,6	5,2	145	40
440.11F	11	24,5	16,9	4,6	8,1	5,5	155	50

⊞	A [mm]	B [mm]	B1 [mm]	E [mm]	E1 [mm]	E2 [mm]	L [mm]	ΔΔ [g]
440.12F	12	27,0	18,0	4,4	8,4	5,8	162	60
440.13F	13	28,7	19,3	4,8	8,6	6,1	170	70
440.14F	14	31,0	21,1	5,7	9,5	6,4	180	85
440.15F	15	32,6	22,2	5,9	10,0	6,8	185	95
440.16F	16	35,6	23,9	6,4	10,5	7,3	195	115
440.17F	17	37,0	25,3	6,5	10,9	7,6	202	130
440.18F	18	38,7	26,0	7,2	11,4	8,1	208	150
440.19F	19	41,2	27,8	7,2	11,9	8,3	216	170

440F - Inch combination wrenches - FLUO

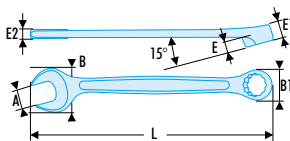

FLUO

ASME B107.100, SAE AS954G

- Fluorescent tool, detectable by ultraviolet light. Detectable in dark and dimly lit areas for 3 metres.
- Standard wrench for all current applications.
- High mechanical strength combined with compact size meeting aeronautical standards.
- Ring head:
 - Ring open end (size E) designed for better access to series or embedded screws.
 - OGV® profile with 12-point ring for powerful tightening while protecting the nut.
 - H suffix = 6-point ring.
 - Ring head angled at 15°.
- Open end head:
 - Open end angled at 15°.
 - Open end head-handle geometry optimised for increased access.
- Dimensions in inches: from 1/4" to 1 1/2".
- Presentation: satin chrome finish.

⊞	A ["]	B [mm]	B1 [mm]	E [mm]	E1 [mm]	E2 [mm]	L [mm]	ΔΔ [g]
440.1/4F	1/4	14,1	10,0	3,1	6,0	3,8	115	20
440.5/16F	5/16	19,2	12,8	3,5	6,7	4,7	133	30
440.11/32F	11/32	21,2	14,2	3,9	7,1	4,7	138	35
440.3/8F	3/8	23,0	15,0	4,2	7,6	5,2	145	45
440.7/16F	7/16	24,5	16,9	4,6	8,1	5,5	155	50
440.1/2F	1/2	28,7	19,3	4,8	8,6	6,1	170	70
440.9/16F	9/16	31,0	21,1	5,7	9,5	6,4	180	85
440.5/8F	5/8	35,6	23,9	6,4	10,5	7,3	195	115
440.11/16F	11/16	37,0	25,3	6,5	10,9	7,6	202	130
440.3/4F	3/4	41,2	27,8	7,2	11,9	8,3	216	170
440.13/16F	13/16	43,1	29,5	6,3	12,3	8,6	224	185

⊞	A ["]	B [mm]	B1 [mm]	E [mm]	E1 [mm]	E2 [mm]	L [mm]	ΔΔ [g]
440.7/8F	7/8	46,9	32,3	8,3	13,3	9,0	248	230
440.15/16F	15/16	51,0	35,0	8,9	14,2	9,7	267	290
440.1PF	1	53,0	36,4	9,4	14,7	9,9	274	315
440.1P1/16F	1 1/16	58,0	39,2	8,9	15,6	10,4	295	375
440.1P1/8F	1 1/8	60,7	40,6	10,6	16,1	10,7	305	415
440.1P1/4F	1 1/4	68,0	46,1	11,5	18,0	12,5	355	640
440.1P5/16F	1 5/16	69,8	47,0	11,8	18,5	12,8	380	715
440.1P3/8F	1 3/8	74,3	51,0	12,8	19,5	13,5	430	890
440.1P7/16F	1 7/16	76,0	53,0	13,2	20,0	14,0	440	945
440.1P1/2F	1 1/2	80,0	56,0	14,1	22,0	15,2	450	1130

Combination wrenches - ratchet wrenches - FLUO

39F - Inch short-reach combination wrenches - FLUO

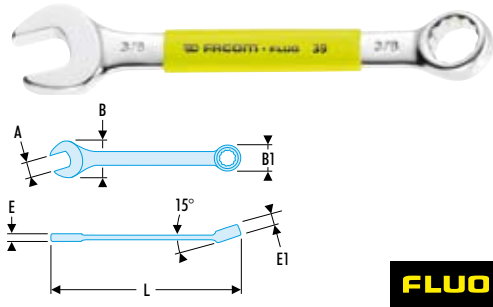

FLUO

ASME B107.100

- Fluorescent tool, detectable by ultraviolet light. Detectable in dark and dimly lit areas for 3 metres.
- Short combination wrenches: the short handle and compact head allow for high handiness. Ideal for confined access.
- OGV® profile with 12-point ring for powerful tightening while protecting the nut. H suffix = 6-point ring.
- Ring head angled at 15°.
- Open end head angled at 15°.
- Dimensions in inches: from 1/8" to 1/2".
- Presentation: satin chrome finish.

39	A ["]	B x B1 [mm]	E [mm]	E1 [mm]	OGV [mm]	L [mm]	ΔΔ [g]
39.1/8HF	1/8	10,0 x 7,0	3,1	3,1	6	77	10
39.5/32HF	5/32	10,0 x 8,0	3,1	3,1	6	77	10
39.3/16HF	3/16	11,8 x 9,0	3,5	4,0	6	82	10
39.7/32HF	7/32	11,8 x 9,5	3,5	4,0	6	84	10
39.1/4F	1/4	15,0 x 10,4	4,1	5,0	6	90	15
39.9/32F	9/32	15,0 x 11,5	4,1	5,0	6	90	15

39	A ["]	B x B1 [mm]	E [mm]	E1 [mm]	OGV [mm]	L [mm]	ΔΔ [g]
39.5/16F	5/16	17,2 x 12,5	4,5	5,8	6	94	20
39.11/32F	11/32	19,4 x 14,0	4,8	6,0	6	98	25
39.3/8F	3/8	21,5 x 15,3	5,1	6,4	6	103	30
39.7/16F	7/16	23,7 x 16,8	5,3	6,8	6	109	35
39.1/2F	1/2	28,0 x 19,5	5,8	8,0	12	141	50

64F - Inch straight ratchet ring wrenches - FLUO

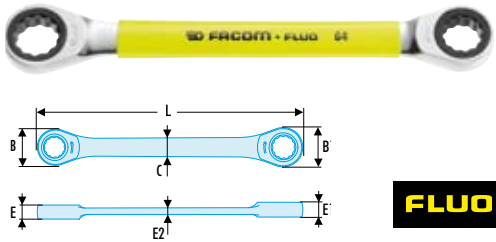

FLUO

ASME B107.100

- Fluorescent tool, detectable by ultraviolet light. Detectable in dark and dimly lit areas for 3 metres.
- Straight ratchet ring wrenches: to reach the nut flat.
- Compact ratchet mechanism and reversible by flipping the wrench.
- Increment 5° (7.5° for dimension 1/4"; 6° for dimensions 5/16" and 11/32").
- Dimensions in inches: from 1/4" to 15/16".
- Presentation: satin chrome finish.

64	A ["]	B1 [mm]	C [mm]	E [mm]	E1 [mm]	E2 [mm]	L [mm]	ΔΔ [g]
64.1/4X5/16F	1/4x5/16	17,2	8,0	6,3	6,5	3,0	115	40
64.5/16X11/32F	5/16x11/32	20,2	8,3	6,5	6,9	3,2	128	45
64.3/8X7/16F	3/8x7/16	21,8	9,1	7,3	7,7	3,6	150	60
64.1/2X9/16F	1/2x9/16	24,8	11,3	8,6	9,0	4,2	180	115

64	A ["]	B1 [mm]	C [mm]	E [mm]	E1 [mm]	E2 [mm]	L [mm]	ΔΔ [g]
64.5/8X11/16F	5/8x11/16	33,5	14,8	9,9	10,7	5,4	210	185
64.3/4X13/16F	3/4x13/16	40,0	15,2	11,2	13,0	5,4	245	310
64.7/8X15/16F	7/8x15/16	46,0	15,2	13	14,5	5,4	260	480

65F - Metric 15° hinged ratchet ring wrenches - FLUO

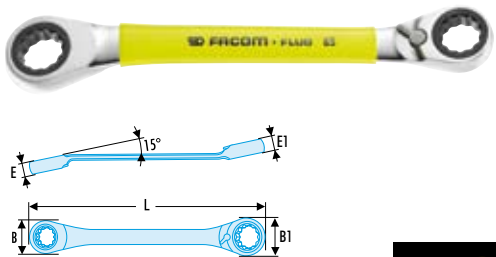

FLUO

NF ISO 1711-1, NF ISO 691, ISO 1711-1, ISO 691, DIN ISO 1711-1, DIN ISO 691, ASME B107.100

- Fluorescent tool, detectable by ultraviolet light. Detectable in dark and dimly lit areas for 3 metres.
- 15° hinged ratchet ring wrenches: ring offset to clear fingers or obstacles.
- Compact ratchet mechanism and reversible by lever.
- Increment 5° (7.5° for dimension 6 mm; 6° for dimensions 7, 8 and 9 mm).
- Ring head angled at 15°.
- Metric sizes: 6 to 24 mm.
- Presentation: satin chrome finish.

65	A [mm]	B [mm]	B1 [mm]	E [mm]	E1 [mm]	L [mm]	ΔΔ [g]
65.6X7F	6x7	14,0	17,0	6,3	6,5	115	30
65.8X9F	8x9	17,0	20,2	6,5	6,9	128	45
65.10X11F	10x11	20,2	22,0	7,3	7,7	150	65
65.12X13F	12x13	23,4	25,5	8,2	8,6	170	90
65.14X15F	14x15	26,9	29,8	9	9,4	190	130
65.16X18F	16x18	29,8	34,0	9,9	10,7	210	190
65.17X19F	17x19	31,8	34,0	10,3	11,2	230	210
65.21X23F	21x23	40,1	46,0	13	14,5	260	430
65.22X24F	22x24	40,1	46,5	13	14,5	260	425

Open end wrenches - FLUO

Fixed and variable opening wrenches

44F - Metric open end wrenches - FLUO

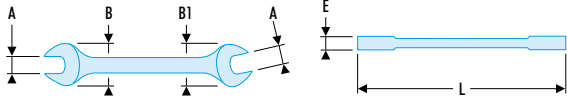

FLUO

NF ISO 10102, NF ISO 3318, NF ISO 1711-1, NF ISO 691, ISO 10102, ISO 3318, ISO 1711-1, ISO 691, DIN ISO 1711-1, DIN ISO 691, DIN 3110

- Fluorescent tool, detectable by ultraviolet light. Detectable in dark and dimly lit areas for 3 metres.
- Open end wrenches = the open ends are slimmer than a standard combination wrench for better thickness accessibility. Examples: brake calipers, hydraulic hose locknuts.
- Heads hinged at 15°.
- Metric sizes: 3.2 to 30 mm.
- Presentation: satin chrome finish.

Size	A [mm]	B x B1 [mm]	E [mm]	L [mm]	ΔΔ [g]
44.3.2X5.5F	3,2x5,5	11,0 x 13,5	3,0	90	10
44.4X5F	4x5	11,0 x 13,5	3,0	90	10
44.6X7F	6x7	15,0 x 17,5	3,5	120	20
44.8X9F	8x9	18,5 x 21,0	3,8	137	30
44.8X10F	8x10	19,0 x 23,0	4,2	143	40
44.10X11F	10x11	23,0 x 25,0	4,7	152	50
44.10X13F	10x13	23,0 x 29,0	5,1	162	60
44.11X13F	24x26	25,5 x 29,0	5,1	167	65
44.12X13F	12x13	25,5 x 29,0	5,1	167	65
44.12X14F	19x22	29,0 x 33,5	5,5	177	80

Size	A [mm]	B x B1 [mm]	E [mm]	L [mm]	ΔΔ [g]
44.13X17F	13x17	31,0 x 37,0	6,3	192	120
44.14X15F	14x15	31,0 x 33,0	5,5	182	90
44.16X17F	16x17	35,5 x 37,0	6,3	200	120
44.16X18F	41x46	37,0 x 42,0	6,8	210	145
44.17X19F	17x19	37,0 x 42,0	6,8	210	145
44.18X19F	18x19	39,0 x 42,0	7,3	220	160
44.20X22F	20x22	43,0 x 48,5	7,5	240	200
44.26X28F	26x28	56,0 x 61,6	8,8	282	360
44.27X29F	27x29	59,0 x 64,0	9,5	301	450
44.27X30F	27x30	59,0 x 64,0	9,5	301	450

44F - Inch open end wrenches - FLUO

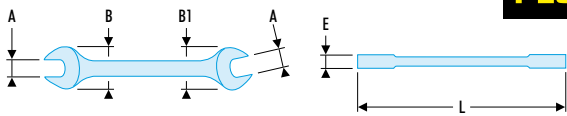

FLUO

ASME B107.100

- Fluorescent tool, detectable by ultraviolet light. Detectable in dark and dimly lit areas for 3 metres.
- Open end wrenches = the open ends are slimmer than a standard combination wrench for better thickness accessibility. Examples: brake calipers, hydraulic hose locknuts.
- Heads hinged at 15°.
- Dimensions in inches: from 1/4" to 15/16".
- Presentation: satin chrome finish.

Size	A ["]	B x B1 [mm]	E [mm]	L [mm]	ΔΔ [g]
44.1/4X5/16F	1/4x5/16	15,0 x 17,5	3,5	120	20
44.11/32X13/32F	11/32x13/32	19,0 x 23,0	4,2	143	40
44.3/8X7/16F	3/8x7/16	23,0 x 25,0	4,7	152	50
44.1/2X9/16F	1/2x9/16	29,0 x 33,5	5,5	177	80
44.5/8X11/16F	5/8x11/16	37,0 x 42,0	6,8	210	145
44.3/4X13/16F	3/4x13/16	43,0 x 48,5	7,5	240	200

Size	A ["]	B x B1 [mm]	E [mm]	L [mm]	ΔΔ [g]
44.1PX1P1/16F	1'X1'1/16	56,0 x 61,6	8,8	282	360
44.1P1/8X1P1/4F	1'1/8X1'1/4	63,0 x 70,0	9,8	318	515
44.1P3/16X1P5/16F	1'3/16X1'5/16	63,0 x 70,0	9,8	318	515
44.1P3/8X1P1/2F	1'3/8X1'1/2	78,0 x 87,0	12,0	381	945
44.7/8X15/16F	7/8X15/16	47,5 x 52,0	8,3	251	260

34F - Inch 15° and 75° hinged "midget" open end wrenches - FLUO

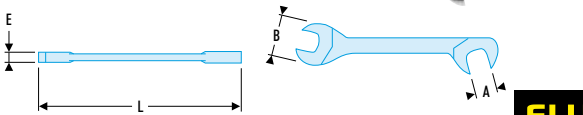

FLUO

ASME B107.100, SAE AS954G

- Fluorescent tool, detectable by ultraviolet light. Detectable in dark and dimly lit areas for 3 metres.
- "Midget" open end wrenches: short shank and slim heads for manoeuvrability in confined spaces.
- Heads hinged at 15° and 75° for better access than a standard wrench.
- Dimensions in inches: from 3/16" to 11/16".
- Presentation: satin chrome finish.

Size	A ["]	B [mm]	E [mm]	L [mm]	ΔΔ [g]
34.3/16F	3/16	13	2,4	75	10
34.7/32F	7/32	13	2,4	75	10
34.1/4F	1/4	15	2,7	80	15
34.9/32F	9/32	15	2,7	80	15
34.5/16F	5/16	18,5	3,0	90	20
34.11/32F	11/32	18,5	3,0	90	20
34.3/8F	3/8	22	3,0	100	25

Size	A ["]	B [mm]	E [mm]	L [mm]	ΔΔ [g]
34.13/32F	13/32	22	3,0	100	30
34.7/16F	7/16	22	3	100	30
34.1/2F	1/2	27	3,5	120	35
34.9/16F	9/16	27	3,5	120	40
34.5/8F	5/8	33	4,5	140	70
34.11/16F	11/16	33	4,5	140	70

Nut driver - adjustable wrenches - Fluo

NUT DRIVER

Nut driver

- Forged body for maximum strength.
- Hollow body allows insertion over long threaded rods.

PROTWIST® handle

- Natural grip and excellent ergonomics.
- Fast and effective approach.
- Comfortable force tightening.
- High torque application with lesser effort.
- Resistance to loads, impacts, abrasion and chemicals.

FLUO



74AF - Forged nut driver - metric - FLUO

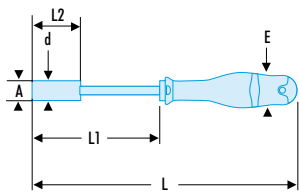

FLUO

NF ISO 2236, NF ISO 691, ISO 2236, ISO 691, DIN 3125, DIN ISO 691

- Fluorescent tool, detectable by ultraviolet light. Detectable in dark and dimly lit areas for 3 metres.
- Nut driver ideal for screws with limited access in height or precision mechanics.
- Protwist screwdriver handle for optimum comfort even for powerful unlocking.
- 6-point socket with deep opening for long threads.
- Forged body for maximum strength.
- Metric sizes: 3.2 to 14 mm.
- Presentation: satin chrome finish.

➤	A [mm]	d [mm]	E [mm]	L [mm]	L1 [mm]	L2 [mm] L3 [mm]	ΔΔ [g]
74A.3,2F	3,2	6,0	36	245	125	20	110
74A.4F	4,0	7,0	36	245	125	20	115
74A.4,5F	4,5	7,5	36	245	125	25	120
74A.5F	5,0	8,0	36	245	125	25	120
74A.5,5F	5,5	8,0	36	245	125	30	120
74A.6F	6,0	9,5	36	245	125	35	125
74A.7F	7,0	9,5	36	245	125	35	130

➤	A [mm]	d [mm]	E [mm]	L [mm]	L1 [mm]	L2 [mm] L3 [mm]	ΔΔ [g]
74A.8F	8,0	12,0	36	245	125	50	155
74A.9F	9,0	12,0	36	245	125	50	160
74A.10F	10,0	14,5	40	250	125	50	200
74A.11F	11,0	16,0	40	250	125	50	210
74A.12F	12,0	17,0	40	250	125	50	210
74A.13F	13,0	18,5	40	250	125	55	250
74A.14F	14,0	20,0	40	250	125	55	255

113A.CF - Chromed adjustable wrenches - FLUO

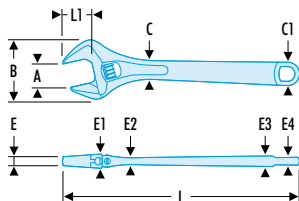

FLUO

NF ISO 6787, ISO 6787, DIN 3117, ASME B107.100

- Fluorescent tool, detectable by ultraviolet light. Detectable in dark and dimly lit areas for 3 metres.
- Good access to the button = easy setting.
- Non-protruding moving jaw at maximum capacity.
- Pre-adjustment of jaw opening thanks to millimetric gradation.
- Right-hand button rotation.
- Range from 4" to 12".
- Presentation: chromed body and polished head faces.

➤	A [mm]	B [mm]	C x C1 [mm]	E [mm]	E1 [mm]	E2 [mm]	E3 [mm]	E4 [mm]	L [mm]	L1 [mm]	ΔΔ [g]
113A.4CF	13	34,0	11,0 x 14,0	14	9,5	5,0	6,5	5,0	114	13	65
113A.6CF	20	45,0	14,8 x 18,5	18,5	11,8	6,0	8,3	5,8	155	19	125
113A.10CF	30	69,5	21,5 x 28,5	28,5	15,5	9,5	12,7	10,0	255	29	480
113A.12CF	34	80,0	25,0 x 31,0	31	18,0	10,2	13,0	10,0	306	34	700

Radio 1/4" range - FLUO

Ratchets - Sockets

Ratchet 1/4"

1/4" maintenance free pear head ratchet - FLUO

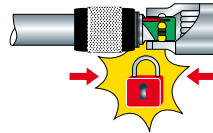
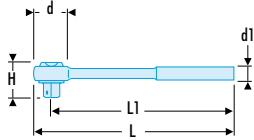

FLUO

NF ISO 3315, ISO 3315, DIN 3122, ASME B107.10

- Fluorescent tool, detectable by ultraviolet light. Detectable in dark and dimly lit areas for 3 metres.
- Dust proof, maintenance free mechanism.
- 72 teeth mechanism for 5° increments.
- Drive direction switch allows easy reversal even with gloved or greasy hands.
- Palm control system - allows the operator to press down on the head avoiding risk of accidental reverse.
- Ultra-compact head.
- Hook for hanging when working at height.
- Ergonomic comfort grip handle design resistant to workshop chemicals and solvents.

Part No.	d [mm]	d1 [mm]	H [mm]	L [mm]	L1 [mm]	ΔΔ [g]
RL.171F	22	20	25	120	110	78

R.RCF - 1/4" drive locking extensions - FLUO

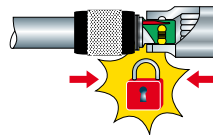

FLUO

NF ISO 3316, ISO 3316, DIN 3123, ASME B107.10

- Fluorescent tool, detectable by ultraviolet light. Detectable in dark and dimly lit areas for 3 metres.
- Locking mechanism.
- Finish: bright chrome.

Part No.	d [mm]	d1 [mm]	d2 [mm]	L [mm]	ΔΔ [g]
R.210RCF	8,2	12	13	100	45
R.215RCF	8,2	12	13	150	60
R.217RCF	8,2	12	13	250	100

65.PEF Bit-holder ratchet wrench 1/4" - 5/16" - FLUO



FLUO

- Fluorescent tool, detectable by ultraviolet light. Detectable in dark and dimly lit areas for 3 metres.
- Takes the following bits:
 - Series 1: hexagon 1/4".
 - Series 2: hexagon 5/16".
- Used for installing 1/4" and 5/16" aircraft fasteners.
- Increment: 5°.
- Heads angled at 15°.
- Bits held by a spring clip.
- Knurled head for fast pre-tightening.
- Length 150 mm.
- Satin chrome finish.
- Weight: 74 g.



RFID



RFID



RFID

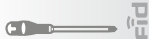

RFID



RFID



RFID



FLUO



FLUO



FLUO



FLUO



FLUO

Radio 1/4" range - FLUO

▣ **R.236CF** 1/4" drive short spinner - FLUO



FLUO

NF ISO 3315, ISO 3315, DIN 3122, ASME B107.10

- Fluorescent tool, detectable by ultraviolet light.
Detectable in dark and dimly lit areas for 3 metres.
 - Ergonomic bi-material grip.
 - Ideal for confined spaces.
- Weight: 76 g.

▣ **R.236AF** 1/4" drive medium spinner - FLUO



FLUO

NF ISO 3315, ISO 3315, DIN 3122, ASME B107.10

- Fluorescent tool, detectable by ultraviolet light.
Detectable in dark and dimly lit areas for 3 metres.
 - Ergonomic bi-material grip.
 - Ideal for confined spaces.
- Weight: 79 g.

▣ **1/4" drive standard spinner - FLUO**

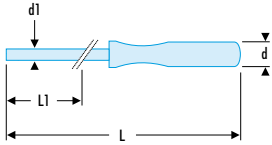

FLUO

NF ISO 3315, ISO 3315, DIN 3122, ASME B107.10

- Fluorescent tool, detectable by ultraviolet light.
Detectable in dark and dimly lit areas for 3 metres.
- Ergonomic bi-material grip.
- Ideal for confined spaces.

▣	d [mm]	d1 [mm]	L [mm]	L1 [mm]	ΔΔ [g]
R.227AF	23,5	8	260	160	125

▣ **1/4" to 3/8" coupler - FLUO**

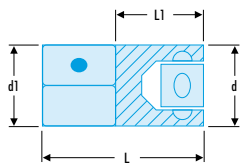

FLUO

NF ISO 3316, ISO 3316, DIN 3123, ASME B107.10

- Fluorescent tool, detectable by ultraviolet light.
Detectable in dark and dimly lit areas for 3 metres.
 - 1/4" female to 3/8" male square drive.
 - For adapting 3/8" drive sockets.
- Finish: bright chrome.

▣	d [mm]	d1 [mm]	L [mm]	L1 [mm]	ΔΔ [g]
R.232F	12	12	24,5	13,5	16

▣ **1/4" drive standard spring-clip bit holder - FLUO**

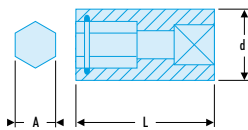

FLUO

NF ISO 1173, ISO 1173

- Fluorescent tool, detectable by ultraviolet light.
Detectable in dark and dimly lit areas for 3 metres.
- Spring clip for frequent bit changes.
- Finish: bright chrome.

▣	A ["]	Carré ["]	d [mm]	L [mm]	ΔΔ [g]
R.235F	1/4	1/4	11,3	22	10

Radio 1/4" range - FLUO

Ratchets - Sockets

1/4" sockets

R.FLUO - 1/4" Drive metric 6-point sockets - FLUO

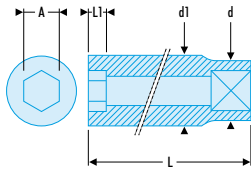

NF ISO 2725-1, NF ISO 1711-1, ISO 2725-1, ISO 1711-1, DIN 3124, ASME B107.5

- Fluorescent tool, detectable by ultraviolet light. Detectable in dark and dimly lit areas for 3 metres.
- OGV® profile: more powerful tightening, preserves fasteners.
- Finish: bright chrome.

Socket	A [mm]	⌀ [mm]	d [mm]	d1 [mm]	L [mm]	L1 [mm]	ΔΔ [g]
R.3.2FLUO	3,2	6	11,2	5,9	22	2,4	7,30
R.4FLUO	4,0	6	11,2	6,9	22	2,6	7,70
R.5FLUO	5,0	6	11,2	8,2	22	4,8	8,10
R.5.5FLUO	5,5	6	11,2	8,8	22	4,8	8,40
R.6FLUO	6,0	6	11,2	9,4	22	5,6	8,60
R.7FLUO	7,0	6	11,0	11,0	22	6,0	9,20
R.8FLUO	8,0	6	12,0	12,0	22	6,5	11,50
R.9FLUO	9,0	6	13,2	13,2	22	6,5	14,30
R.10FLUO	10,0	6	14,7	14,7	22	7,8	17,70
R.11FLUO	11,0	6	15,8	15,8	22	9,0	19,40
R.12FLUO	12,0	6	17,0	17,0	22	9,50	23,20
R.13FLUO	13,0	6	17,7	17,7	22	10,00	23,70
R.14FLUO	14,0	6	18,7	18,7	22	10,00	26,10

R.FLUO - 1/4" Drive inch 6-point sockets - FLUO

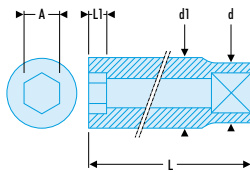

ASME B107.1

- Fluorescent tool, detectable by ultraviolet light. Detectable in dark and dimly lit areas for 3 metres.
- OGV® profile: more powerful tightening, preserves fasteners.
- Finish: bright chrome.

Socket	A ["]	⌀ [mm]	d [mm]	d1 [mm]	L [mm]	L1 [mm]	ΔΔ [g]
R.3/16FLUO	3/16	6	11,2	8,0	22	4,75	8,20
R.7/32FLUO	7/32	6	11,2	9,0	22	5,50	8,30
R.1/4FLUO	1/4	6	11,2	10,1	22	6,00	9,30
R.9/32FLUO	9/32	6	11,0	11,0	22	6,00	8,90
R.5/16FLUO	5/16	6	12,0	12,0	22	6,50	11,50
R.11/32FLUO	11/32	6	13,2	13,2	22	6,50	14,50
R.3/8FLUO	3/8	6	14,7	14,7	22	7,80	17,80
R.13/32FLUO	13/32	6	14,7	14,7	22	7,80	17,00
R.7/16FLUO	7/16	6	15,8	15,8	22	9,00	19,50
R.1/2FLUO	1/2	6	17,7	17,7	22	10,00	24,50
R.9/16FLUO	9/16	6	18,7	18,7	22	10,00	25,20

R.EF - 1/4" Drive inch 12-point sockets - FLUO

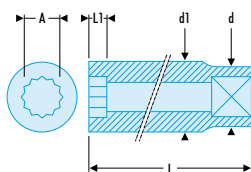

ASME B107.1

- Fluorescent tool, detectable by ultraviolet light. Detectable in dark and dimly lit areas for 3 metres.
- OGV® profile: more powerful tightening, preserves fasteners.
- Finish: bright chrome.

Socket	A ["]	⌀ [mm]	d [mm]	d1 [mm]	L [mm]	L1 [mm]	ΔΔ [g]
R.3/16EF	3/16	12	11,2	8,0	22	4,75	8,20
R.7/32EF	7/32	12	11,2	9,0	22	5,50	8,30
R.1/4EF	1/4	12	11,2	10,1	22	6,00	9,30
R.9/32EF	9/32	12	11,2	10,6	22	6,00	8,90
R.5/16EF	5/16	12	12,0	12,0	22	6,50	11,50
R.11/32EF	11/32	12	13,0	13,0	22	6,50	14,50
R.3/8EF	3/8	12	14,7	14,7	22	7,80	17,80
R.13/32EF	13/32	12	14,7	14,7	22	7,80	17,00
R.7/16EF	7/16	12	15,8	15,8	22	9,00	19,5
R.1/2EF	1/2	12	17,7	17,7	22	10,00	24,5
R.9/16EF	9/16	12	18,7	18,7	22	10,00	25,20

Radio 1/4" range - FLUO

■ R.ELF - 1/4" long-reach metric 12-point sockets - FLUO

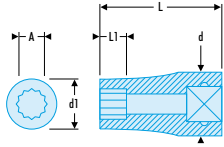

NF ISO 2725-1, NF ISO 1711-1, ISO 2725-1, ISO 1711-1, DIN 3124, ASME B107.5

- Fluorescent tool, detectable by ultraviolet light. Detectable in dark and dimly lit areas for 3 metres.
- OGV® profile: more powerful tightening, preserves fasteners.
- Long-reach sockets for long recess or thread access.
- High performance, suitable for aircraft fasteners to AS954E.
- Thinner socket walls for better accessibility.
- Finish: bright chrome.

➤	A [mm]	⊙ [mm]	d [mm]	d1 [mm]	L [mm]	L1 [mm]	ΔΔ [g]
R.4ELF	4	12	6,7	11,2	50	4	18
R.4,5ELF	4,5	12	7,3	11,2	50	4,5	18
R.5ELF	5	12	7,8	11,2	50	5,5	18
R.5,5ELF	5,5	12	8,5	11,2	50	6	18
R.6ELF	6	12	9,2	11,2	50	7	18
R.7ELF	7	12	10,3	11,2	50	8	27
R.8ELF	8	12	11,2	11,7	50	9	27
R.9ELF	9	12	13	12	50	10	32
R.10ELF	10	12	14,3	12,9	50	11	41
R.11ELF	11	12	15,5	14,3	50	12	54
R.12ELF	12	12	16,8	15,5	50	13	56
R.13ELF	13	12	18	16,4	50	14	59
R.14ELF	14	12	19,3	17,9	50	16	68

■ R.ELF - 1/4" long-reach inch 12-point sockets - FLUO

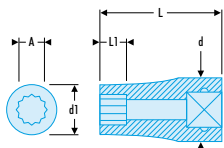

ASME B107.1

- Fluorescent tool, detectable by ultraviolet light. Detectable in dark and dimly lit areas for 3 metres.
- OGV® profile: more powerful tightening, preserves fasteners.
- Long-reach sockets for long recess or thread access.
- High performance, suitable for aircraft fasteners to AS954E.
- Thinner socket walls for better accessibility.
- Available as rack set (Ref REL.40U).
- Finish: bright chrome.

➤	A ["]	⊙ [mm]	d [mm]	d1 [mm]	L [mm]	L1 [mm]	ΔΔ [g]
R.3/16ELF	3/16	12	10,9	7,7	50	6,0	14
R.7/32ELF	7/32	12	10,9	8,5	50	7,4	15
R.1/4ELF	1/4	12	10,9	9,4	50	7,4	17
R.9/32ELF	9/32	12	10,9	10,2	50	8,5	17
R.5/16ELF	5/16	12	11,8	11,4	50	9,0	23
R.11/32ELF	11/32	12	12,0	12,5	50	9,7	25
R.3/8ELF	3/8	12	12,8	13,7	50	11,2	32
R.7/16ELF	7/16	12	14,3	15,6	50	11,9	40
R.1/2ELF	1/2	12	16,2	17,3	50	13,8	45
R.9/16ELF	9/16	12	17,1	18,8	50	16,2	49

■ REL.40UF 1/4" inch long socket set on rack - FLUO



- Fluorescent tool, detectable by ultraviolet light. Detectable in dark and dimly lit areas for 3 metres.
- 10 long socket set from 3/16" to 9/16"
- Weight: 45 g.

Junior 3/8" range - FLUO

Ratchets - Sockets

Ratchet 3/8"

3/8" maintenance free pear head ratchet - RFID

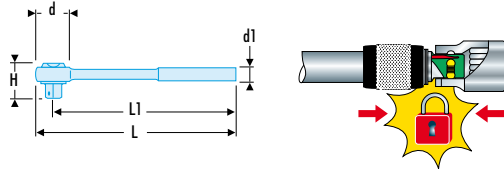

FLUO

NF ISO 3315, ISO 3315, DIN 3122, ASME B107.10

- Fluorescent tool, detectable by ultraviolet light.
Detectable in dark and dimly lit areas for 3 metres.
- Dust proof, maintenance free mechanism.
- 72 teeth mechanism for 5° increments.
- Drive direction switch allows easy reversal even with gloved or greasy hands.
- Palm control system - allows the operator to press down on the head avoiding risk of accidental reverse.
- Ultra-compact head.
- Hook for hanging when working at height.
- Ergonomic comfort grip handle design resistant to workshop chemicals and solvents.

RFID	d [mm]	d1 [mm]	H [mm]	L [mm]	L1 [mm]	ΔΔ [g]
JL.171F	29	27	29	210	195	200

3/8" sockets

J.FLUO - 3/8" inch 12-point sockets - FLUO

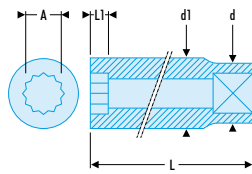

FLUO

ASME B107.1

- Fluorescent tool, detectable by ultraviolet light.
Detectable in dark and dimly lit areas for 3 metres.
- OGV® profile: more powerful tightening, preserves fasteners.
- Finish: bright chrome.

RFID	A ["]	⚙ [mm]	d [mm]	d1 [mm]	L [mm]	L1 [mm]	ΔΔ [g]
J.1/4FLUO	1/4	12	17,5	10,0	27	6,0	24
J.5/16FLUO	5/16	12	17,5	11,9	27	6,5	25
J.3/8FLUO	3/8	12	17,6	14,1	27	7,5	26
J.7/16FLUO	7/16	12	17,5	16,0	27	9,0	27
J.1/2FLUO	1/2	12	17,5	18,1	30	10,4	36
J.9/16FLUO	9/16	12	17,7	19,5	30	10,5	34
J.5/8FLUO	5/8	12	20,0	22,0	30	12,0	46
J.11/16FLUO	11/16	12	21,0	24,0	33	13,0	74
J.3/4FLUO	3/4	12	22,7	26,0	33	14,0	76
J.13/16FLUO	13/16	12	23,0	28,0	33	16,0	79
J.7/8FLUO	7/8	12	24,7	29,7	33	16,5	104

J.LAF - 3/8" inch 12-point sockets - FLUO

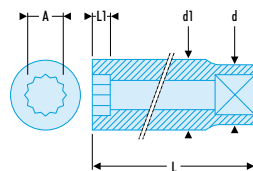

FLUO

ASME B107.1

- Fluorescent tool, detectable by ultraviolet light.
Detectable in dark and dimly lit areas for 3 metres.
- OGV® profile: more powerful tightening, preserves fasteners.
- Long-reach sockets for long recess or thread access.
- Finish: bright chrome.

RFID	A ["]	⚙ [mm]	d [mm]	d1 [mm]	L [mm]	L1 [mm]	ΔΔ [g]
J.1/4LAF	1/4	12	17,5	10,6	44,7	4,0	36
J.5/16LAF	5/16	12	17,5	12,4	44,7	4,3	36
J.3/8LAF	3/8	12	17,5	14,3	44,7	4,7	41
J.7/16LAF	7/16	12	17,5	16,2	44,7	6,2	45
J.1/2LAF	1/2	12	18,2	18,2	44,7	7,4	50
J.9/16LAF	9/16	12	20,5	20,5	48,0	9,0	72
J.5/8LAF	5/8	12	22,3	22,3	63,8	10,2	104
J.11/16LAF	11/16	12	23,8	23,8	63,8	10,2	113
J.3/4LAF	3/4	12	25,3	25,3	63,8	11,8	127
J.13/16LAF	13/16	12	27,0	27,0	63,8	12,3	140
J.7/8LAF	7/8	12	30,2	30,2	63,8	12,7	181

Fluo Screwdrivers

PROTWIST® FLUO Screwdrivers

ANF - PROTWIST® screwdrivers for slotted head screws - milled blades - FLUO

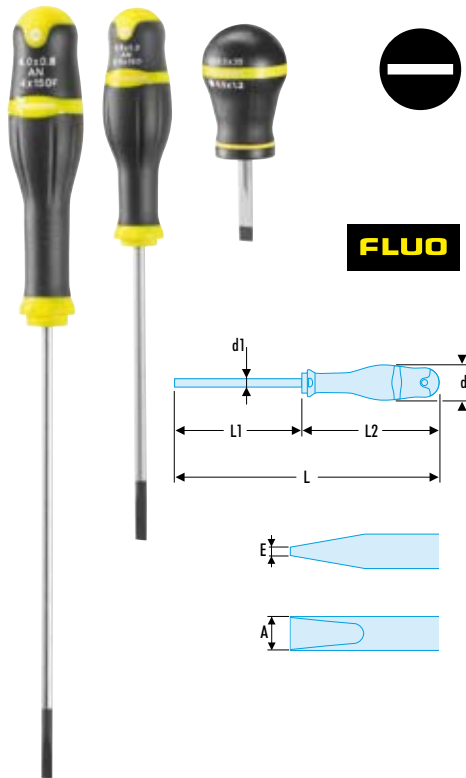

NF ISO 2380-1, NF ISO 2380-2, ISO 2380-1, ISO 2380-2, DIN ISO 2380-1, DIN ISO 2380-2, ASME B107.600

- Fluorescent tool, detectable by ultraviolet light. Detectable in dark and dimly lit areas for 3 metres.
- Round shank for access in wells.
- Extra-long shank up to 300 mm for difficult and remote access.
- Silicon carbon blade: strong and resistant to flexion.
- Bi-material grip resists to impacts, abrasion, and chemicals.
- Finish: black tipped mat chromed blade.

➤	A [mm]	d [mm]	d1 x L1 [mm]	E [mm]	L [mm]	L2 [mm]	ΔΔ [g]
AN2X75F	2,0	19	2,0 x 75	0,4	169	94	18
AN2.5X75F	2,5	19	2,5 x 75	0,4	169	94	21
AN3X100F	3,0	25	3,0 x 100	0,5	203	103	33
AN3.5X100F	3,5	25	3,5 x 100	0,6	203	103	43
AN4X35F	4,0	36	4,0 x 35	0,8	91	56	36
AN4X100F	4,0	30	4,0 x 100	0,8	209	109	47
AN4X150F	4,0	30	4,0 x 150	0,8	259	109	52
AN5.5X150F	5,5	30	5,5 x 150	1,0	259	109	91
AN6.5X35F	6,5	36	6,5 x 35	1,2	91	56	46
AN6.5X150F	6,5	36	6,5 x 150	1,2	270	120	140

ANPF - PROTWIST® screwdrivers for Phillips® screws - round blades - FLUO



NF ISO 8764-1, NF ISO 8764-2, ISO 8764-1, ISO 8764-2, DIN ISO 8764-1, DIN ISO 8764-2, ASME B107.600

- Fluorescent tool, detectable by ultraviolet light. Detectable in dark and dimly lit areas for 3 metres.
- Extra-long blade up to 400 mm for difficult and remote access.
- Silicon carbon blade: strong and resistant to flexion.
- Bi-material grip resists to impacts, abrasion, and chemicals.
- Finish: black tipped mat chromed blade.

➤	Phillips [No]	d [mm]	d1 x L1 [mm]	L [mm]	L2 [mm]	ΔΔ [g]
ANPOX75F	PH0	25	3,0 x 75	178	103	45
ANP1X35F	PH1	36	4,5 x 35	91	56	39
ANP1X100F	PH1	30	4,5 x 100	209	109	76
ANP1X250F	PH1	30	4,5 x 250	359	109	99
ANP2X35F	PH2	36	6,0 x 35	91	56	44
ANP2X125F	PH2	36	6,0 x 125	245	120	126
ANP2X250F	PH2	36	6,0 x 250	370	120	153
ANP2X400F	PH2	36	6,0 x 400	520	120	186
ANP3X150F	PH3	40	8,0 x 150	275	125	194
ANP4X200F	PH4	40	10,0 x 200	325	125	277

Fluo Screwdrivers

Screwdrivers - Keys

AWF - PROTWIST® screwdrivers for slotted head screws - hexagonal blades - FLUO

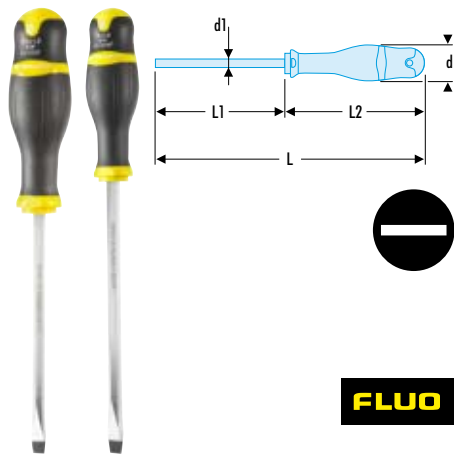

NF ISO 2380-1, NF ISO 2380-2, ISO 2380-1, ISO 2380-2, DIN ISO 2380-1, DIN ISO 2380-2, ASME B107.600

- Fluorescent tool, detectable by ultraviolet light.
Detectable in dark and dimly lit areas for 3 metres.
- Hexagonal blade for optimum reliability and performance.
- Extra-long shank up to 250 mm for difficult and remote access.
- Silicon carbon blade: strong and resistant to flexion.
- Bi-material grip resists to impacts, abrasion, and chemicals.
- Finish: black tipped mat chromed blade.

➤	d [mm]	d1 x L1 [mm]	L [mm]	L2 [mm]	ΔΔ [g]
AW8X150F	40	7 x 150	275	125	220
AW10X200F	40	9 x 200	325	125	255

AWPF - PROTWIST® screwdrivers for Phillips® screws - hexagonal blades - FLUO

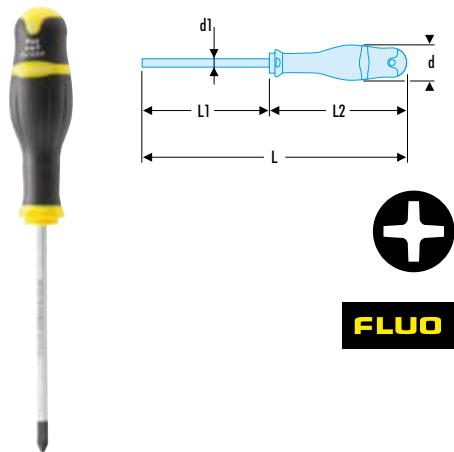

NF ISO 8764-1, NF ISO 8764-2, ISO 8764-1, ISO 8764-2, DIN ISO 8764-1, DIN ISO 8764-2, ASME B107.600

- Fluorescent tool, detectable by ultraviolet light.
Detectable in dark and dimly lit areas for 3 metres.
- Hexagonal blade for optimum reliability and performance.
- Silicon carbon blade: strong and resistant to flexion.
- Bi-material grip resists to impacts, abrasion, and chemicals.
- Finish: black tipped mat chromed blade.

➤	Phillips [No]	d [mm]	d1 x L1 [mm]	L [mm]	L2 [mm]	ΔΔ [g]
AWP2X125F	PH2	36	6 x 125	245	120	130

ANDF - PROTWIST® screwdrivers for Pozidriv® screws - round blades - FLUO

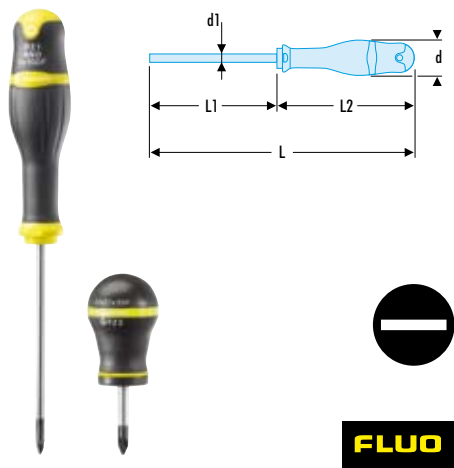

NF ISO 8764-1, NF ISO 8764-2, ISO 8764-1, ISO 8764-2, DIN ISO 8764-1, DIN ISO 8764-2, ASME B107.600

- Fluorescent tool, detectable by ultraviolet light.
Detectable in dark and dimly lit areas for 3 metres.
- Silicon carbon blade: strong and resistant to flexion.
- Bi-material grip resists to impacts, abrasion, and chemicals.
- Finish: black tipped mat chromed round blade.

➤	A [mm]	d [mm]	d1 x L1 [mm]	L [mm]	L2 [mm]	ΔΔ [g]
AND0X75F	PZ0	25	3,0 x 75	178	103	45
AND1X100F	PZ1	30	4,5 x 100	209	109	76
AND1X250F	PZ1	30	4,5 x 250	359	109	99
AND2X125F	PZ2	36	6,0 x 125	245	120	126
AND2X250F	PZ2	36	6,0 x 250	370	120	153
AND3X150F	PZ3	40	8,0 x 150	275	125	194
AND1X35F	PZ1	36	4,5 x 35	91	56	40
AND2X35F	PZ2	36	6,0 x 35	91	56	45

Fluo Screwdrivers

ANXR - PROTWIST® screwdrivers for Torx® and Resistorx® screws

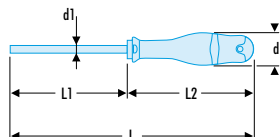

- Fluorescent tool, detectable by ultraviolet light.
Detectable in dark and dimly lit areas for 3 metres.
- Compliant with Resistorx® specifications.
- Silicon carbon blade: strong and resistant to flexion.
- Bi-material grip resists to impacts, abrasion, and chemicals.
- Finish: black tipped mat chromed blade.

➤	A [mm]	Resistorx [No]	d [mm]	d1 x L1 [mm]	L [mm]	L2 [mm]	ΔΔ [g]
ANXR10X75F	2,74	TT10	25	3,0 x 75	184	109	50
ANXR15X75F	3,26	TT15	30	3,5 x 75	185	110	61
ANXR20X100F	3,84	TT20	36	4,0 x 100	220	120	67
ANXR25X100F	4,40	TT25	36	5,0 x 100	220	120	113
ANXR27X100F	4,96	TT27	36	5,5 x 100	220	120	113
ANXR30X125F	5,49	TT30	36	6,0 x 125	245	120	126
ANXR40X150F	6,60	TT40	40	7,0 x 150	275	125	173

PROTWIST® FLUO hexagon keys

AWSH.F - Spherical head spinner hexagon keys - FLUO

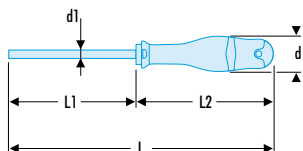

- Fluorescent tool, detectable by ultraviolet light.
Detectable in dark and dimly lit areas for 3 metres.
- Bi-material ergonomic PROTWIST® handle for comfortable and reliable screwing.

➤	A [mm]	d [mm]	d1 x L1 [mm]	L [mm]	L2 [mm]	ΔΔ [g]
AWSH2X75F	2,0	19	2,0 x 75	169	94	31
AWSH2,5X75F	2,5	19	2,5 x 75	169	94	33
AWSH3X75F	3,0	19	3,0 x 75	169	94	35
AWSH4X75F	4,0	25	4,0 x 75	178	103	45
AWSH5X100F	5,0	30	5,0 x 100	208	109	80
AWSH6X100F	6,0	36	6,0 x 100	220	120	120
AWSH8X100F	8,0	36	8,0 x 100	220	120	180

Fluo hexagon keys

Screwdrivers - Keys

Set of hexagon keys in wallet FLUO

83SH.JP8UF Set of 8 hexagon keys in wallet - FLUO



FLUO

- Fluorescent tool, detectable by ultraviolet light. Detectable in dark and dimly lit areas for 3 metres.
 - 8 keys 83SH in inches: 3/32 - 1/8 - 5/32 - 3/16 - 7/32 - 1/4 - 5/16 - 3/8".
 - Very compact sleeve.
 - Positive grip.
 - Keys on 90° end stop for tightening.
 - Keys in silicon steel issued from series 82H.
 - Finish: phosphate-coated.
- Weight: 365 g.

83SH.JP9F Set of 9 hexagon keys in wallet - FLUO



FLUO

- Fluorescent tool, detectable by ultraviolet light. Detectable in dark and dimly lit areas for 3 metres.
 - 9 metric keys 83SH: 1,5 - 2 - 2,5 - 3 - 4 - 5 - 6 - 8 - 10 mm.
 - Very compact sleeve.
 - Positive grip.
 - Keys on 90° end stop for tightening.
 - Keys in silicon steel issued from series 82H.
 - Finish: phosphate-coated.
- Weight: 380 g.

86HF - Hexagon keys on sleeve - FLUO



FLUO

- Fluorescent tool, detectable by ultraviolet light. Detectable in dark and dimly lit areas for 3 metres.
- Very compact sleeve.
- Positive grip.
- Keys on 90° end stop for tightening.
- Keys in silicon steel issued from series 82H.
- Finish: phosphate-coated.

Model	Key sizes [mm]	Angle [°]	d [mm]	d1 [mm]	L [mm]	L1 [mm]	ΔΔ [g]
86H.JE7AF	2,5 - 3,0 - 4,0 - 5,0 - 6,0 - 8,0 - 10,0	-	30	24	138	32	405
86H.JE7BF	1,5 - 2,0 - 2,5 - 3,0 - 4,0 - 5,0 - 6,0	-	22	18	118	28	147
86H.JU6F	-	5/32 - 3/16 - 7/32 - 1/4 - 5/16 - 3/8	30	24	138	32	420
86H.JU7F	-	1/16 - 5/64 - 3/32 - 1/8 - 5/32 - 3/16 - 1/4	22	18	118	28	142



RFID



RFID



RFID



RFID



RFID



RFID



FLUO



FLUO



FLUO



FLUO



FLUO

Fluo hexagon keys

82HF - Short metric and inch keys - FLUO

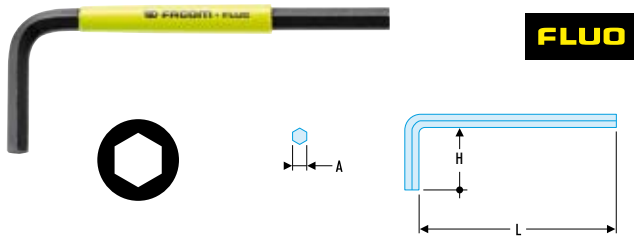

ASME B18.3 - for keys in inch
NF ISO 2936, ISO 2936, DIN ISO 2936,
ASME B18.3.2M - for metric keys

- Fluorescent tool, detectable by ultraviolet light.
 Detectable in dark and dimly lit areas for 3 metres.
- Manufactured in silicon steel.
- Finish: phosphate-coated.

⇒	A [mm]	A ["]	H [mm]	L [mm]	ΔΔ [g]
82H.0,9F	0,9	-	12	38	0,30
82H.1,3F	1,3	-	13	45	0,70
82H.1,5F	1,5	-	13	45	0,90
82H.2F	2,0	-	16	50	2,00
82H.2,5F	2,5	-	17	62	3,00
82H.3F	3,0	-	20	65	5,00
82H.3,5F	3,5	-	22	66	8,00
82H.4F	4,0	-	25	70	10,00
82H.4,5F	4,5	-	26	75	15,00
82H.5F	5,0	-	28	80	20,00
82H.6F	6,0	-	32	90	30,00
82H.7F	7,0	-	34	95	45,00
82H.8F	8,0	-	36	100	60,00
82H.9F	9,0	-	38	105	80,00
82H.10F	10,0	-	40	112	100,00
82H.11F	11,0	-	42	118	130,00
82H.12F	12,0	-	45	125	165,00
82H.13F	13,0	-	50	135	205,00

⇒	A [mm]	A ["]	H [mm]	L [mm]	ΔΔ [g]
82H.050F	-	0,50	12	38	0,40
82H.3/64F	-	3/64	12	38	0,50
82H.1/16F	-	1/16	13	45	0,70
82H.5/64F	-	5/64	16	50	2,00
82H.3/32F	-	3/32	17	62	3,00
82H.7/64F	-	7/64	18	60	4,00
82H.1/8F	-	1/8	20	65	6,00
82H.9/64F	-	9/64	22	66	8,00
82H.5/32F	-	5/32	25	70	10,00
82H.3/16F	-	3/16	28	80	16,00
82H.7/32F	-	7/32	32	90	24,00
82H.1/4F	-	1/4	32	90	33,00
82H.5/16F	-	5/16	36	100	59,00
82H.3/8F	-	3/8	40	112	90,00
82H.1/2F	-	1/2	45	125	202,00
82H.5/8F	-	5/8	60	160	383,00
82H.7/8F	-	7/8	80	200	955,00

84TZSF - Spherical head metric hexagon keys - FLUO

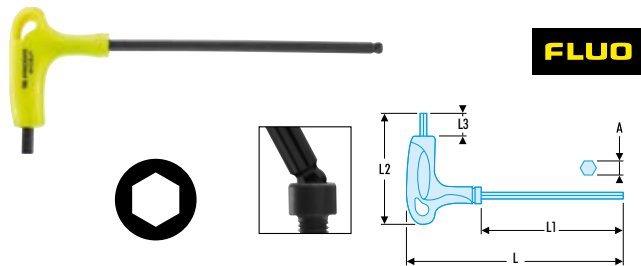

- Fluorescent tool, detectable by ultraviolet light.
 Detectable in dark and dimly lit areas for 3 metres.
- Ergonomic T handle for efficient use of the two ends of the key.
- The spherical head allows for screwing with a tilt angle up to 30°. Use the short hexagon key for tightening.
- Silicon steel.
- Finish: polished, phosphate-coated.

⇒	A [mm]	L [mm]	L1 [mm]	L2 [mm]	L3 [mm]	ΔΔ [g]
84TZS.4F	4	183	130	77	12	58
84TZS.5F	5	183	130	77	12	70
84TZS.6F	6	240	175	95	15	112

⇒	A [mm]	L [mm]	L1 [mm]	L2 [mm]	L3 [mm]	ΔΔ [g]
84TZS.7F	7	240	175	95	15	120
84TZS.8F	8	240	175	95	15	125
84TZS.10F	10	240	175	95	15	192

84TZF - Metric and inch hexagon keys - FLUO

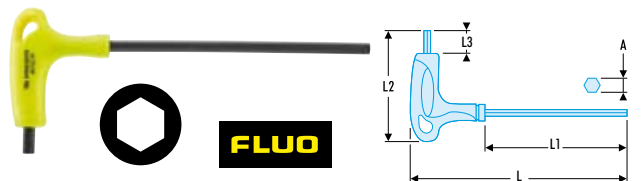

- Fluorescent tool, detectable by ultraviolet light.
 Detectable in dark and dimly lit areas for 3 metres.
- Ergonomic T handle for efficient use of the two ends of the key.
- Silicon steel.
- Finish: polished, phosphate-coated.

⇒	A [mm]	A ["]	L [mm]	L1 [mm]	L2 [mm]	L3 [mm]	ΔΔ [g]
84TZ.2,5F	2,5	-	133	90	63	11	9
84TZ.3F	3,0	-	133	90	63	11	12
84TZ.4F	4,0	-	183	130	77	12	58
84TZ.5F	5,0	-	183	130	77	12	70
84TZ.6F	6,0	-	240	175	95	15	112
84TZ.8F	8,0	-	240	175	95	15	125
84TZ.10F	10,0	-	240	175	95	15	192

⇒	A [mm]	A ["]	L [mm]	L1 [mm]	L2 [mm]	L3 [mm]	ΔΔ [g]
84TZ.5/32F	-	5/32	183	130	77	12	58
84TZ.3/16F	-	3/16	183	130	77	12	65
84TZ.7/32F	-	7/32	240	175	95	15	80
84TZ.1/4F	-	1/4	240	175	95	15	115
84TZ.5/16F	-	5/16	240	175	95	15	125
84TZ.3/8F	-	3/8	240	175	95	15	180

AM.F - PROTWIST® bit holder screwdriver - FLUO

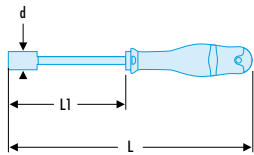

FLUO

- Fluorescent tool, detectable by ultraviolet light. Detectable in dark and dimly lit areas for 3 metres.
- Bit lock.
- Square drive has side-hole for ball or plunger lock.

	d [mm]	L [mm]	L1 [mm]	ΔΔ [g]
AM.M2F	10	245	125	150

Bit holder and accessories for non impact powered screwing

EF.F - 1/4" drive lock-ring bit holder - FLUO



FLUO

NF ISO 2725-3, NF ISO 1173, ISO 2725-3, ISO 1173, DIN 3124

- Fluorescent tool, detectable by ultraviolet light. Detectable in dark and dimly lit areas for 3 metres.
- Bit lock.
- Square drive has side-hole for ball or plunger lock.

	A ["]	L [mm]	Carré ["]	ΔΔ [g]
EF.RF	1/4	30	1/4	26
EF.JF	1/4	43	3/8	48

EF.6RF Socket holder - 1/4" square drive - FLUO



FLUO

NF ISO 1173, ISO 1173

- Fluorescent tool, detectable by ultraviolet light. Detectable in dark and dimly lit areas for 3 metres.
- Drive 1/4" - 6.35 mm.
- Locking by plunger.
- Length: 50 mm.
- Weight: 16 g.

EF.6RLF Long socket holder - 1/4" square drive - FLUO



FLUO

NF ISO 1173, ISO 1173

- Fluorescent tool, detectable by ultraviolet light. Detectable in dark and dimly lit areas for 3 metres.
- Drive 1/4" - 6.35 mm.
- Locking by plunger.
- Length: 100 mm.
- Weight: 38 g.



RFID



RFID



RFID



RFID



RFID



RFID



FLUO



FLUO



FLUO



FLUO



FLUO

Fluo pliers

181A.F - Locking twin slip-joint multigrip pliers - FLUO

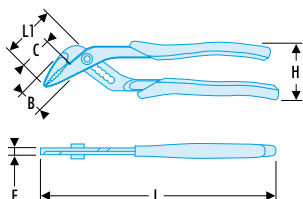

FLUO

NF ISO 8976, ISO 8976, DIN ISO 8976, ASME B107.500

- Fluorescent tool, detectable by ultraviolet light.
Detectable in dark and dimly lit areas for 3 metres.
- Fast, precise push-button adjustment with safety lock.
- 12-position notches.
- The closed position of the ergonomic comfort grip handles increases the tightening power.
- High torsional strength.
- Slim-profile self-gripping nose.
- 62 HRC high-frequency treated jaws.
- Finish: chromed, bi-material ergonomic grips

➤	B [mm]	C [mm]	E [mm]	L [mm]	L1 [mm]	Capacité écrous [mm]	ΔΔ [g]
181A.18CPEF	22	24	7,5	185	48	36	230
181A.25CPEF	28	28	7,5	245	54	41	360

192.CPEF - High-performance diagonal cutters - FLUO

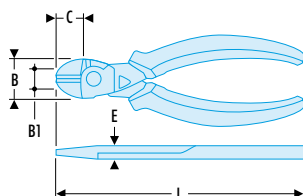

FLUO

NF ISO 5749, ISO 5749, DIN ISO 5749, ASME B107.500

- Fluorescent tool, detectable by ultraviolet light.
Detectable in dark and dimly lit areas for 3 metres.
- Cutting edges designed to cleanly cut all types of wire: piano wire, soft wires and modern materials 200 kg/mm²).
- Minimum cutting force thanks to long lever arm and offset axis.
- High durability Chrome-Molybdenum-Vanadium steel, very hard cutting edges 61/63 HRC.
- Ergonomic grips resistant to chemical agents.
- Removable return spring.
- Finish: chromed.

➤	B [mm]	C [mm]	d maxi [mm]	E [mm]	L [mm]	ΔΔ [g]
192.14CPEF	21,5	15,5	1,4	9,5	145	160
192.16CPEF	24,0	18,0	1,6	10,0	160	200
192.20CPEF	28,0	22,0	2,0	11,5	200	320

190.CPEF - High-performance end cutters - FLUO

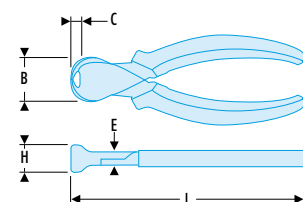

FLUO

NF ISO 5748, ISO 5748, DIN ISO 5748, ASME B107.500

- Fluorescent tool, detectable by ultraviolet light.
Detectable in dark and dimly lit areas for 3 metres.
- Cutting edges designed to cleanly cut all types of wire: piano wire, hard and soft wires (max. 200 kg/mm²).
- Long lever arm, offset pivot for minimum cutting effort.
- High durability Chrome-Molybdenum-Vanadium steel, very hard cutting edges 61/63 HRC.
- Ergonomic grips resistant to chemical agents.
- Removable return spring.
- Finish: chromed.

➤	A [mm]	B [mm]	C [mm]	E [mm]	L [mm]	ΔΔ [g]
190.16CPEF	6,5	28	6,5	11,5	160	200
190.20CPEF	7,5	31	7,5	13,5	200	340

Fluo pliers

Pliers

Long half-round nose pliers - FLUO

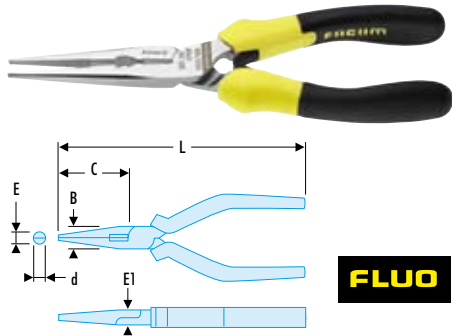

NF ISO 5745, ISO 5745, DIN ISO 5745, ASME B107.500

- Fluorescent tool, detectable by ultraviolet light. Detectable in dark and dimly lit areas for 3 metres.
- Narrow, finely serrated tips with a pipe-grip.
- Side cutter for copper and hard steel wire (max. 160 kg/mm²).
- Straight nose.
- Ergonomic grips resistant to chemical agents.
- Removable return spring.
- Finish: chromed.

➤	B [mm]	C [mm]	d [mm]	E [mm]	E1 [mm]	L [mm]	ΔΔ [g]
185.20CPEF	18	75	2,9	3,6	9	200	192

Short half-round nose pliers - FLUO

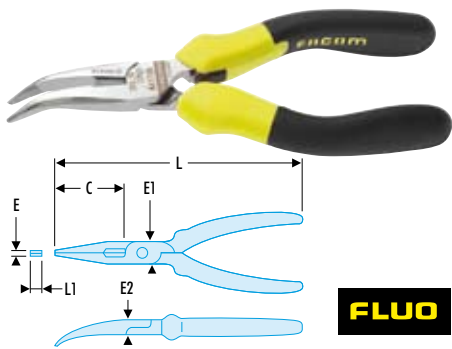

NF ISO 5745, ISO 5745, DIN ISO 5745, ASME B107.500

- Fluorescent tool, detectable by ultraviolet light. Detectable in dark and dimly lit areas for 3 metres.
- Narrow, finely serrated tips, 40° angled nose.
- Side cutter for copper and hard steel wire (max. 160 kg/mm²).
- Ergonomic grips resistant to chemical agents.
- Removable return spring.
- Finish: chromed.

➤	B [mm]	C [mm]	d [mm]	E [mm]	E1 [mm]	L [mm]	ΔΔ [g]
195.16CPEF	17	50	2,5	3	9	160	177

Half-round long snipe-nose pliers - FLUO

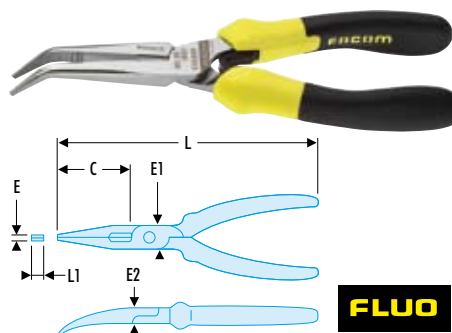

NF ISO 5745, ISO 5745, DIN ISO 5745, ASME B107.500

- Fluorescent tool, detectable by ultraviolet light. Detectable in dark and dimly lit areas for 3 metres.
- Narrow, finely serrated tips, 40° angled nose.
- Side cutter for copper and hard steel wire (max. 160 kg/mm²).
- Ergonomic grips resistant to chemical agents.
- Removable return spring.
- Finish: chromed.

➤	C [mm]	E [mm]	E1 [mm]	E2 [mm]	L [mm]	L1 [mm]	ΔΔ [g]
183.20CPEF	69	3	18	9	200	2,5	185

Short half-round nose pliers - FLUO

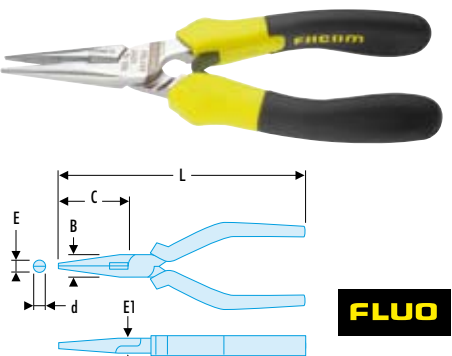

NF ISO 5745, ISO 5745, DIN ISO 5745, ASME B107.500

- Fluorescent tool, detectable by ultraviolet light. Detectable in dark and dimly lit areas for 3 metres.
- Narrow, finely serrated tips.
- Side cutter for copper and hard steel wire (max. 160 kg/mm²).
- Ergonomic grips resistant to chemical agents.
- Removable return spring.
- Finish: chromed.

➤	B [mm]	C [mm]	d [mm]	E [mm]	E1 [mm]	L [mm]	ΔΔ [g]
193.16CPEF	17	50	2,5	3	9	160	177



Fluo pliers

187.CPEF - Combination pliers - FLUO

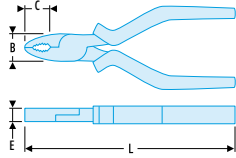

FLUO

NF ISO 5746, ISO 5746, DIN ISO 5746, ASME B107.500

- Fluorescent tool, detectable by ultraviolet light. Detectable in dark and dimly lit areas for 3 metres.
- Cutting edges designed to cut all types of wire: piano wire, soft wires and modern materials (Fe 200 kg/mm²).
- Long lever arm, offset pivot for minimum cutting effort.
- High durability Chrome-Molybdenum-Vanadium steel, very hard cutting edges 61/63 HRC.
- Ergonomic grips resistant to chemical agents.
- Removable return spring.
- Finish: chromed.

	B [mm]	C [mm]	E [mm]	L [mm]	ΔΔ [g]
187.16CPEF	21	34	9,5	165	195
187.18CPEF	23	36	10,0	185	225

188.CPEF - Flat nose pliers - FLUO

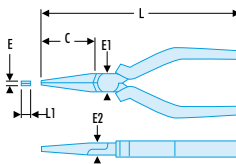

FLUO

NF ISO 5745, ISO 5745, DIN ISO 5745, ASME B107.500

- Fluorescent tool, detectable by ultraviolet light. Detectable in dark and dimly lit areas for 3 metres.
- Serrated nose for a firm grip.
- 188.E: snipe nose version for confined spaces.
- Ergonomic grips resistant to chemical agents.
- Removable return spring.
- Finish: chromed.

	C [mm]	E [mm]	E1 [mm]	E2 [mm]	L [mm]	L1 [mm]	ΔΔ [g]
188.16CPEF	46	4,0	18	9	168	6,5	140
188.20CPEF	75	4,0	18	9	200	6,5	200

Round nose pliers - FLUO

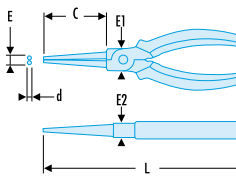

FLUO

NF ISO 5745, ISO 5745, DIN ISO 5745, ASME B107.500

- Fluorescent tool, detectable by ultraviolet light. Detectable in dark and dimly lit areas for 3 metres.
- For shaping loops, bends or rings.
- Finely serrated jaws for positive grip.
- Diameter of each nose at the end: 2 mm.
- Ergonomic grips resistant to chemical agents.
- Removable return spring.
- Finish: chromed.

	C [mm]	d [mm]	E [mm]	E1 [mm]	E2 [mm]	L [mm]	ΔΔ [g]
189.17CPEF	41	2	4	18	9	170	135

Fluo pliers

Pliers

Micro-Tech® Diagonal cutters - FLUO

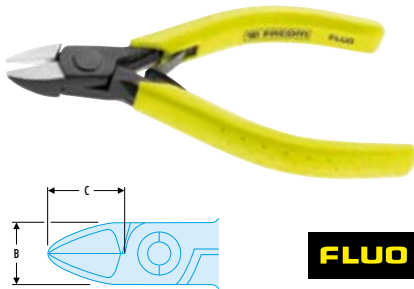

NF ISO 5749, ISO 5749, DIN ISO 5749, ASME B107.500

- Fluorescent tool, detectable by ultraviolet light. Detectable in dark and dimly lit areas for 3 metres.
- Axial cut.
- Finish: mat burnished finish, red grips - return spring.

➤	B [mm]	C [mm]	E [mm]	L [mm]	L1 [mm]	ΔΔ [g]
405.12F	16,0	16,0	16,0	120	8	95

Micro-Tech® Half-round nose pliers - FLUO

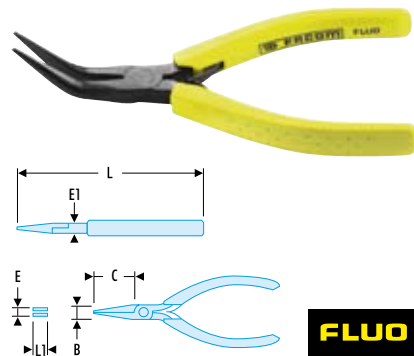

NF ISO 5745, ISO 5745, DIN ISO 5745, ASME B107.500

- Fluorescent tool, detectable by ultraviolet light. Detectable in dark and dimly lit areas for 3 metres.
- Smooth jaws, angled 40°.
- Finish: mat burnished finish, red grips - return spring.

➤	B [mm]	C [mm]	E [mm]	E1 [mm]	L [mm]	L1 [mm]	ΔΔ [g]
403F	45	14	14	1,2	155	8	75

Micro-Tech® Diagonal cutters - FLUO - FLUO

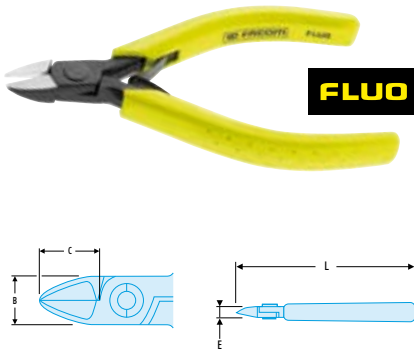

NF ISO 9654, ISO 9654, DIN ISO 9654, ASME B107.500

- Fluorescent tool, detectable by ultraviolet light. Detectable in dark and dimly lit areas for 3 metres.
- 425: Flush cut, nose extended 13 mm.
- Finish: mat burnished finish, red grips - return spring.

➤	B [mm]	C [mm]	E [mm]	L [mm]	Cu - Ni Ø [mm]	Coupe	ΔΔ [g]
425F	13,0	10,5	10,5	110	0,1 - 1,3	┌	60

Micro-Tech® "compact" cutters: handling - FLUO

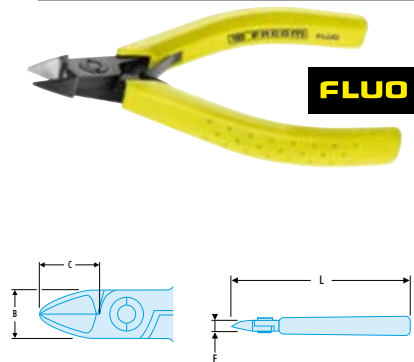

NF ISO 9654, ISO 9654, DIN ISO 9654, ASME B107.500

- Fluorescent tool, detectable by ultraviolet light. Detectable in dark and dimly lit areas for 3 metres.
- These pliers combine cutting performance with handling thanks to their new slim diagonal shape.
- Fall prevention models avoid wire ejection. The 405.MT pliers allow to cut piano wire up to 0.4 mm. Weight: 60 g.

➤	B [mm]	C [mm]	E [mm]	L [mm]	Retenue de chute	Coupe	Fe 30 HRc diam. [mm]	Cu - Ni Ø [mm]	Piano diam. [mm]
406.RMTF	10,5	9,5	7	110	•	┌	0,6	0,1 - 1,1	-



RFID



RFID



RFID



RFID



RFID



RFID



FLUO



FLUO



FLUO



FLUO



FLUO

Fluo pliers

Micro-Tech® “rugged” cutters: versatility - FLUO

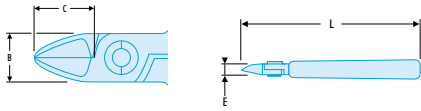

NF ISO 9654, ISO 9654, DIN ISO 9654, ASME B107.500

- Fluorescent tool, detectable by ultraviolet light. Detectable in dark and dimly lit areas for 3 metres.
 - These pliers allow neat cutting of multiple materials: from copper wire to piano wire up to 0.5 mm.
 - 405.10RMT: Fall prevention models avoid wire ejection.
- Weight: 60 g.

	B [mm]	C [mm]	E [mm]	L [mm]	Cu - Ni Ø [mm]	Fe 30 HRc diam. [mm]	Coupe	ΔΔ [g]
405.10MTF	10,5	11,5	7	110	0,3 - 1,4	0,8	∧	60
405.10RMTF	10,5	11,5	7	110	0,3 - 1,4	0,7	∧	60

Micro-Tech® “machined” cutters - FLUO

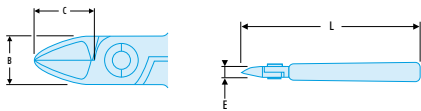

NF ISO 9654, ISO 9654, DIN ISO 9654, ASME B107.500

- Fluorescent tool, detectable by ultraviolet light. Detectable in dark and dimly lit areas for 3 metres.
 - Compact noses for difficult access.
 - Fall prevention models avoid wire ejection.
- Weight: 60 g.

	B [mm]	C [mm]	E [mm]	L [mm]	Retenu de chute	Coupe	Fe 30 HRc diam. [mm]	Cu - Ni Ø [mm]
416.RMTF	10,5	10,5	7	110	•	∧	0,5	0,1 - 0,9

Micro-Tech® long and rigid nose grippers - FLUO

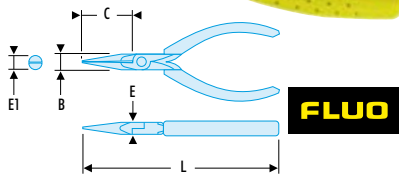

NF ISO 9655, ISO 9655, DIN ISO 9655, ASME B107.500

- Fluorescent tool, detectable by ultraviolet light. Detectable in dark and dimly lit areas for 3 metres.
- Weight: 70 g.

	B [mm]	C [mm]	E [mm]	E1 [mm]	L [mm]
422.MTF	11	33	7	0,5	130

• Solutions FACOM.FLUO



Fluo pliers

Pliers

Micro-Tech® 60° angled rigid nose grippers - FLUO

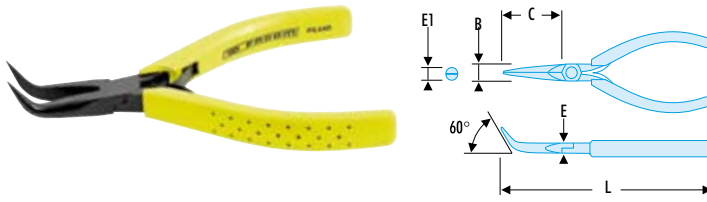

FLUO

NF ISO 9655, ISO 9655, DIN ISO 9655, ASME B107.500

- Fluorescent tool, detectable by ultraviolet light.
- Detectable in dark and dimly lit areas for 3 metres.
- Weight: 70 g.

➤	B [mm]	C [mm]	E [mm]	E1 [mm]	L [mm]
423.MTF	11	25	7	1,4	125

Micro-Tech® long and rigid nose grippers - FLUO



FLUO

NF ISO 9655, ISO 9655, DIN ISO 9655, ASME B107.500

- Fluorescent tool, detectable by ultraviolet light.
- Detectable in dark and dimly lit areas for 3 metres.
- Weight: 70 g.

➤	B [mm]	C [mm]	E [mm]	E1 [mm]	L [mm]	L1 [mm]
421.MTF	11	33	7	1	130	5

Micro-Tech® thin nose grippers - FLUO



FLUO

NF ISO 9655, ISO 9655, DIN ISO 9655, ASME B107.500

- Fluorescent tool, detectable by ultraviolet light.
- Detectable in dark and dimly lit areas for 3 metres.
- Narrow mesh, for high precision works.
- Weight: 80 g.

➤	B [mm]	C [mm]	E [mm]	E1 [mm]	L [mm]
431.LMTF	9	20	6	1	135

Micro-Tech® 45° angled thin nose grippers - FLUO



FLUO

NF ISO 9655, ISO 9655, DIN ISO 9655, ASME B107.500

- Fluorescent tool, detectable by ultraviolet light.
- Detectable in dark and dimly lit areas for 3 metres.
- Fine mesh, for high precision works.
- Weight: 75 g.

➤	B [mm]	C [mm]	E [mm]	E1 [mm]	L [mm]
433.LMTF	9	35	6	1,6	135



RFID



RFID



RFID



RFID



RFID



RFID



FLUO



FLUO



FLUO



FLUO



FLUO

Fluo pliers

Outside circlip® pliers - FLUO



NF E 73-130, DIN 5254, ASME B107.500

- Fluorescent tool, detectable by ultraviolet light. Detectable in dark and dimly lit areas for 3 metres.
- 177A.18F = Straight nose
197A.18F = 90° angled nose
- For outside Circlips® 19 --> 60 mm.
- Piano wire tips: high distortion resistance.
- Long 10° angled tips for optimum circlip holding.
- Identification colour code: saves time.

➤	d [mm]	d mini - maxi [mm]	L [mm]	ΔΔ [g]
177A.18F	1,8	19 - 60	180	175
197A.18F	1,8	19 - 60	170	175

Inside circlip® pliers - FLUO



NF E 73-130, DIN 5256, ASME B107.500

- Fluorescent tool, detectable by ultraviolet light. Detectable in dark and dimly lit areas for 3 metres.
- 179A.18F = Straight nose
199A.18F = 90° angled nose
- For inside Circlips® 19 --> 60 mm.
- Piano wire tips: high distortion resistance.
- Long 10° angled tips for optimum circlip holding.
- Identification colour code: saves time.

➤	d [mm]	d mini - maxi [mm]	L [mm]	ΔΔ [g]
179A.18F	1,8	19 - 60	185	215
199A.18F	1,8	19 - 60	170	215

467FLUO Outside circlip® pliers - FLUO



NF E 73-130, DIN 5254, ASME B107.500

- Fluorescent tool, detectable by ultraviolet light. Detectable in dark and dimly lit areas for 3 metres.
 - Interchangeable tips for a capacity of diam. 8 --> 63 mm.
 - Thumbscrew position setting.
 - Opening return spring.
 - Finish: chrome finish, red PVC grips.
 - Supplied in a case with key and set of bits E1 - E2 - E3 - E5 - E6 - E8 - E9.
- Weight: 160 g.

469F Outside circlip® pliers - FLUO



NF E 73-130, DIN 5256, ASME B107.500

- Fluorescent tool, detectable by ultraviolet light. Detectable in dark and dimly lit areas for 3 metres.
 - Interchangeable tips for a capacity of diam. 8 --> 63 mm.
 - Thumbscrew position setting.
 - Opening return spring.
 - Finish: chrome finish, red PVC grips.
 - Supplied in a case with key and set of bits E1 - E2 - E3 - E5 - E6 - E8 - E9.
- Weight: 160 g.

Fluo pliers

Pliers

449BF Standard crimping pliers for insulated terminals - FLUO

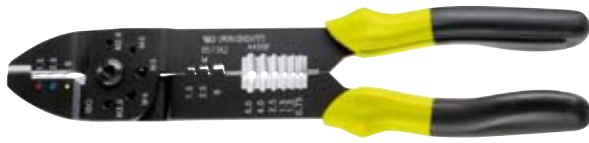

FLUO

- Fluorescent tool, detectable by ultraviolet light. Detectable in dark and dimly lit areas for 3 metres.
 - Crimping pre-insulated terminals: 1.5-2.5-6 mm².
 - Crimping bare terminals: 1.5-2.5-6 mm².
 - Stripping: 0.75 to 6 mm²
 - Built-in wire cutting function.
- Weight: 320 g.

Short-nose lock-grip pliers - FLUO

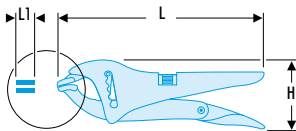

FLUO

ASME B107.500

- Fluorescent tool, detectable by ultraviolet light. Detectable in dark and dimly lit areas for 3 metres.
- 4-position slip joint system.
- Nose width 17 mm.
- Machined groove in upper jaw holds small round sections.
- Finish: chromed.

	H [mm]	L [mm]	L1 [mm]	ΔΔ [g]
500F	58	225	17	540

“Connector” pliers

“Connector” pliers - FLUO

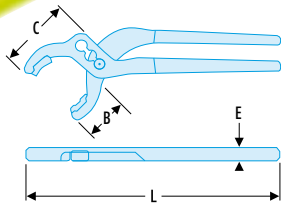
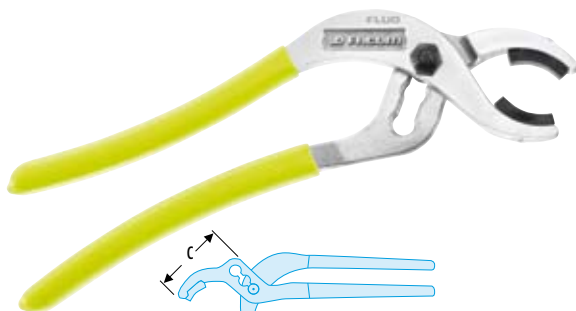

FLUO

ASME B107.500

- Fluorescent tool, detectable by ultraviolet light. Detectable in dark and dimly lit areas for 3 metres.
 - For handling fragile round components, e.g. screwed connector sleeves, tubes, lamps or wire looms, etc.
 - Wide capacity from 3-position slip joint: max. diameter 55 mm.
 - Replaceable plastic jaws available in 2 jaw hardness options:
 - 410.SF: soft jaws - 55 shore B.
 - Finish: polished chrome, red PVC grips.
- 410.SF: Set of 2 jaws with screws (soft).

	B [mm]	C [mm]	E [mm]	L [mm]	ΔΔ [g]
410.SF	68	47	10	230	320

Locking-wire pliers

445.F - Locking-wire pliers - FLUO

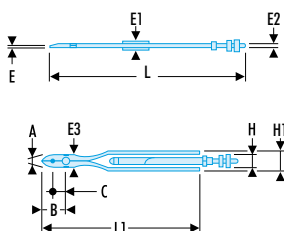

FLUO

ASME B107.500

- Fluorescent tool, detectable by ultraviolet light. Detectable in dark and dimly lit areas for 3 metres.
- 445.8RF = short 8" / 445.10RF = 10"
- Automatic model.
- Side wire-cutter: stainless steel diameter 1 mm.
- 3 turns: 125 mm length.

	A [mm]	B [mm]	C [mm]	E [mm]	E1 [mm]	E2 [mm]	E3 [mm]	H [mm]	H1 [mm]	L [mm]	L1 [mm]	ΔΔ [g]
445.8RF	3	20	7	2,5	15	10,5	15	22	37	215	170	245
445.10RF	3	30	11	2,5	15,5	11,5	19	25	40	360	230	400

Rules - Gauges

DELA.1051F - Stainless steel rules - 2 sides - FLUO

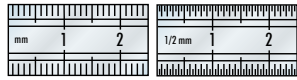
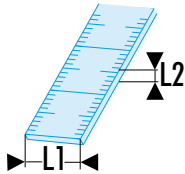

FLUO

- Fluorescent tool, detectable by ultraviolet light. Detectable in dark and dimly lit areas for 3 metres.
- Engraved on both sides.
- One edge in mm - One edge in 1/2 mm.
- Stainless steel 18 % Cr - 8 % Ni.
- Anti-reflection treatment.
- Class II as per regulations applies to rules with a length above or equal to 500 mm.

DE	L [mm]	L1 x L2 [mm]	ΔΔ [g]
DELA.1051.02F	150	13 x 0,5	8,5
DELA.1051.03F	200	13 x 0,5	10,9
DELA.1051.04F	250	13 x 0,5	13,5
DELA.1051.05F	300	13 x 0,5	16,1

Stainless steel rules - 1 side - FLUO

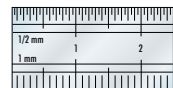
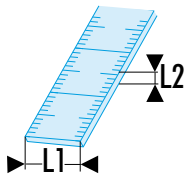

FLUO

- Fluorescent tool, detectable by ultraviolet light. Detectable in dark and dimly lit areas for 3 metres.
- Engraved on one side.
- One edge in mm - One edge in 1/2 mm.
- Stainless steel 18 % Cr - 8 % Ni.
- Anti-reflection treatment.
- Class II as per regulations applies to rules with a length above or equal to 500 mm.

DE	L [mm]	L1 x L2 [mm]	ΔΔ [g]
DELA.1021.02F	150	13 x 0,5	8,5

804F Round tip metric thickness gauges - FLUO



FLUO

- Fluorescent tool, detectable by ultraviolet light. Detectable in dark and dimly lit areas for 3 metres.
- Set of 19 feeler gauges (round tip): 4/100 --> 100/100 mm.
- Blade length: 90 mm.
- Weight: 60 g.

804.LF Long metric thickness gauges - FLUO

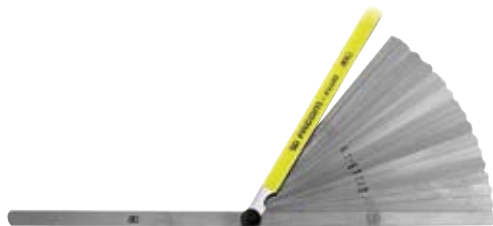

FLUO

- Fluorescent tool, detectable by ultraviolet light. Detectable in dark and dimly lit areas for 3 metres.
- Set of 19 feeler gauges (round tip): 4/100 --> 25/100 mm.
- Blade length: 150 mm.

Measuring - Marking out

Measuring - Hammers - Lighting

893.FLUO - ABS body tape measure - FLUO



FLUO

- Fluorescent tool, detectable by ultraviolet light. Detectable in dark and dimly lit areas for 3 metres.
- Ergonomic, ABS material.
- Tape with mat anti-reflection nylon tape.
- High strength tape.
- High strength cover hook:
 - 2 rivets with stainless reinforcement plate on the 2 and 3 m.
 - 3 rivets with stainless reinforcement plate on the 5 and 8 m.
- Interior measurements by adding the L dimension (see table).

FACOM	E [mm]	H [mm]	L [mm]	L1 [mm]	L2 [m]	ΔΔ [g]
893.213FLUO	24	52	55	13	2	78
893.316FLUO	27	60	60	16	3	126
893.519FLUO	31	67	70	19	5	197

Steel scribers

234F Steel scriber - FLUO



FLUO

- Fluorescent tool, detectable by ultraviolet light. Detectable in dark and dimly lit areas for 3 metres.
- Tip treated in chrome vanadium steel.
- Tip: Ø 4 mm.
- Length: 190 mm.
- Weight: 20 g.



Hammers - Mallets

Graphite handle riveting engineers hammer - FLUO

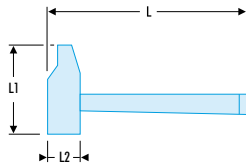

FLUO

NF E 71-016, NF ISO 15601, ISO 15601

- Fluorescent tool, detectable by ultraviolet light. Detectable in dark and dimly lit areas for 3 metres.
- Ergonomic safety handle with graphite core.

☞	L [mm]	L1 [mm]	L2 [mm]	ΔΔ [kg]
200C.30F	270	93	30	0,470

208A.F - Adaptable-tip mallets - FLUO



FLUO

- Fluorescent tool, detectable by ultraviolet light. Detectable in dark and dimly lit areas for 3 metres.
- Steel body "heavy" series hammers.
- Mallets are available with a limited number of tip combinations only, but you can customize your mallet by selecting a body and two tips of your choice.
- Tips available:
 - EA series: neoprene.
 - EB series: polyurethane.
 - EC series: nylon.

☞	d [mm]	Embouts	ΔΔ [kg]
208A.32BBAF	32	EB - EB	0,350
208A.32CBAF	32	EC - EB	0,345

Mallet tips - FLUO



FLUO

- Fluorescent tool, detectable by ultraviolet light. Detectable in dark and dimly lit areas for 3 metres.
- Heavyweight steel body, hickory handle.

☞	d [mm]	L [mm]	Manche	Présentation	ΔΔ [kg]
208A.32AF	32	300	210.MHB13	Laiton	0,295

Mallets - Impact tools

Measuring - Hammers - Lighting

212AF - Dead-blow hammers, interchangeable tips - FLUO

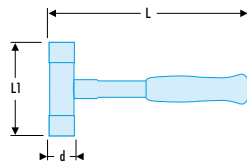

FLUO

- Fluorescent tool, detectable by ultraviolet light. Detectable in dark and dimly lit areas for 3 metres.
- Glass fiber handle.
- Steel body.
- Easily replaceable, special nylon tips shore hardness D74 ± 5.
- Ergonomic PVC grip.
- Presentation: black epoxy.
- Spare tip: 212.E35 to E60.

Ref	d [mm]	L [mm]	L1 [mm]	Embouts	ΔΔ [kg]
212A.35F	35	305	112	212.E35	0,698
212A.40F	40	310	117	212.E40	0,839

Drifts

249.F - Standard drift punches - FLUO

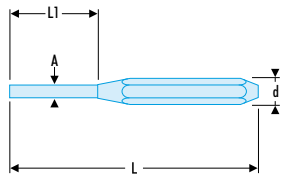

FLUO

NF E 71-211, DIN 6450, ASME B107.410

- Fluorescent tool, detectable by ultraviolet light. Detectable in dark and dimly lit areas for 3 metres.
- Hexagonal shank, high-strength steel tip, hardened to 53-58 HRc.
- Zinc-plated finish.

Ref	A [mm]	d [mm]	L [mm]	L1 [mm]	ΔΔ [kg]
249.2F	1,9	8	115	30	0,030
249.3F	2,9	8	125	40	0,035
249.4F	3,9	10	150	50	0,065
249.5F	4,9	10	165	50	0,075
249.6F	5,9	12	180	50	0,120
249.8F	7,9	12	200	50	0,160
249.10F	9,9	16	200	50	0,220

Drift punches

256.F - Precision centre punches - FLUO

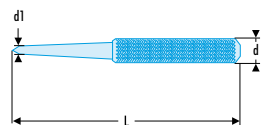

FLUO

NF E 71-211, DIN 7250, ASME B107.410

- Fluorescent tool, detectable by ultraviolet light. Detectable in dark and dimly lit areas for 3 metres.
- Chrome-vanadium steel forged, hardened to 52 to 58 HRc.
- Presentation: knurled body.
- Zinc-plated finish.

Ref	A [mm]	d [mm]	L [mm]	ΔΔ [kg]
256.4F	4	8	105	0,035
256.6F	6	10	115	0,060
256.8F	8	12	130	0,100

Lighting

779.CL3FL LED INSPECTION LAMP

Dual light

- Directive UV torch light for detection of fluorescent tools.
- Soft permanent lighting on the front to light a work zone.

Hautes performances

- Very long lasting LEDs.
- White fluorescent panel lighting with diffusing glass.

Extended use

- 5h panel lighting.
- Charges in 2h30.
- High capacity Lithium-Ion battery without memory effect.

Proven resistance

- Shock-proof structure (IK08). Drop resistant.
- Watertight construction (IP55).
- Resists workshop solvents and common chemicals.

Safety - Comfort

- Low operating temperature -> does not burn.
- Compact design -> for better accessibility.
- Magnet fastener or notched 360° swivel hook.
- Wall or worktop charger.
- 2 m mains cable.
- Blinks 15 min before lamp discharges.



Torch light UV

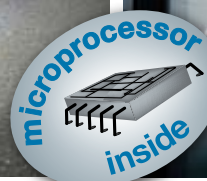
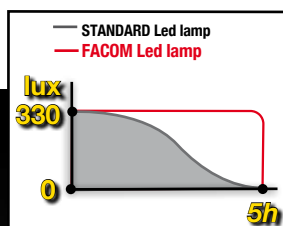
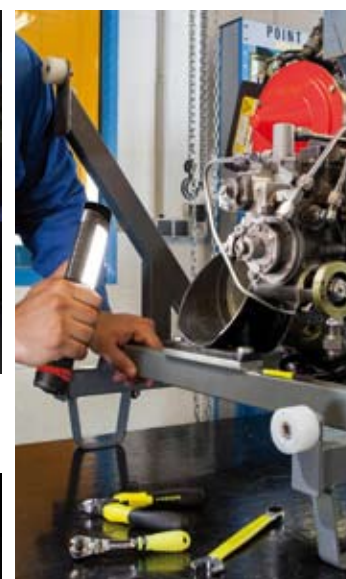

779.CL3FL Cordless LED Inspection lamp - FLUO



FLUO

- Directive UV torch light for detection of fluorescent tools.
- Wide light diffusion on work area for productivity in every kind of work place. (front)
- Battery charger EURO 100-240V.
- 360 Lumen.
- Extended use: up to 5 hours.
- 100% "hands free" : magnet fastener or notched 360° swivel hook.
- Shock-proof structure.
- Short press: Soft permanent lighting on the front to light a work zone.
- Long press: Powerful directive torch light UV.
- Dimensions (L. x l. x H.): 242 x 61 x 50 mm.
- Weight: 380 g.

779.CL3FLUK - model equipped with a UK plug

Scissors - Mirror

Measuring - Hammers - Lighting

Electricians scissors - FLUO

FLUO

- Fluorescent tool, detectable by ultraviolet light. Detectable in dark and dimly lit areas for 3 metres.
- 100% metal handles, left/right hand.
- Short reinforced blades, with wire cutter.
- Finish: polished chromed.

	L [mm]	Lame	$\Delta\Delta$ [g]
841F	150	33	95

834B.RTF Inspection mirror - FLUO

FLUO

- Fluorescent tool, detectable by ultraviolet light. Detectable in dark and dimly lit areas for 3 metres.
- Mirror in scratch resistant glass, available as spare parts.
- Metallic strapping around the glass for better protection.
- Join easily adjustable, or even locked, by screw.
- Solvent resistant plastic handle: Skydroll, gasoil.
- Max length 850 mm.
- Mirror diameter 55 mm.

- 834B.RT01: Spare mirror.

FACOM.FLUO

FLUO



FLUO



FLUO



FLUO



FLUO



FLUO



FLUO



FLUO



FLUO



FLUO



FLUO

Your distributor



RFid TECHNOLOGY BY FACOM



FACOM • FLUO

