



SERIA 1/4" «RADIO»

237



Zestawy nasadek 1/4"	237
Grzechotki 1/4"	245
Akcesoria 1/4"	247
Nasadki 1/4"	252
Nasadki 1/4" długie	254
Nasadki 1/4" Torx®	255
Nasadki trzpieniowe 1/4"	255

SERIA 1/2" «STANDARDOWA»

276



Zestawy nasadek 1/2"	276
Grzechotki 1/2"	289
Akcesoria 1/2"	292
Nasadki 1/2"	297
Nasadki Torx® 1/2"	300
Nasadki trzpieniowe 1/2"	300

SERIA 3/8" «JUNIOR»

257



Zestawy nasadek 3/8"	257
Grzechotki 3/8"	264
Akcesoria 3/8"	266
Nasadki 3/8"	271
Nasadki Torx® 3/8"	274
Nasadki trzpieniowe 3/8"	274

SERIA 3/4" «SAMOCHODY CIĘŻAROWE»

303



Zestawy nasadek 3/4"	303
Grzechotki 3/4"	309
Akcesoria 3/4"	311
Nasadki 3/4"	314



SERIA 1" «MAMUT»

316



Zestawy nasadek 1"	316
Grzechotki i akcesoria 1"	317
Nasadki 1"	318

SERIA «UDAROWA»

319



Nasadki i akcesoria udarowe 3/8"	321
Nasadki i akcesoria udarowe 1/2"	323
Nasadki i akcesoria udarowe 3/4"	331
Nasadki i akcesoria udarowe 1"	334
Nasadki i akcesoria udarowe 1" 1/2	337

KLUCZE UDAROWE RĘCZNE DYNAPACT

339



Wkrętak do pobijania
 ↳ Patrz rozdział 7 na stronie**464**

DOBÓR NASADEK

SERWIS, PARAMETRY I BEZPIECZEŃSTWO FACOM







FACOM udostępniła ponad 1500 pozycji grzechotek, nasadek, akcesoriów i skrzynek, spełniających wszystkie wymagania, do użytku ręcznego, do pracy z elektronarzędziami lub pod napięciem.

PARAMETRY









- Grzechotki, nasadki i akcesoria FACOM posiadają parametry techniczne daleko przekraczające wymagania obowiązujących norm.

BEZPIECZEŃSTWO

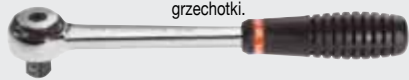
- Ze względów bezpieczeństwa należy przestrzegać kodów kolorów oraz pozostałych zasad bezpieczeństwa.
 - Chromowane: Wyłącznie do użytku ręcznego
 - Pomarańczowe: Do użytku ręcznego pod napięciem.
 - Czarne: Do użytku z narzędziami udarowymi lub zasilanymi.
 - Brąz/miedź: Do użytku w otoczeniu wybuchowym.

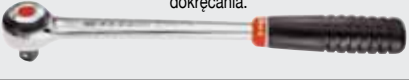
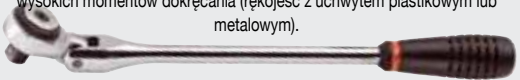
KOLOR NASADKI LUB AKCESORIÓW	ZASTOSOWANIE	WYMIARY	KWADRAT ZABIERAKA	
Chromowany 	Mała mechanika Elektronika Elektronika Elektromechanika	Od 3,2 do 14 mm Od 3/16" do 9/16"	Seria „Radio” 1/4"	str. 250
Chromowany 	Mechanika ogólna Mechanika samochodowa	Od 7 do 24 mm Od 1/4" do 1"	Seria „Junior” 3/8"	str. 258
	Motocykle	Od 8 do 34 mm Od 1/4" do 1"	Seria standardowa 1/2"	str. 276
Chromowany 	Mechanika ogólna Samochody ciężarowe	Od 19 do 55 mm Od 3/4" do 2"1/4.	Seria do samochodów ciężarowych 3/4"	str. 393
	Roboty budowlane i drogowe Maszyny rolnicze Platformy wiertnicze	Od 41 do 100 mm Od 1"13/16 do 3"3/8	Seria „Mamut” 1"	str. 316
Czarny 	Wszystkie dokręcania z użyciem elektronarzędzi	Od 6 do 120 mm Od 3/8" do 2"1/8.	Seria udarowa 3/8", 1/2", 3/4", 1", 1"1/2.	str. 320
		Klucze udarowe ręczne	str. 678	
		Urządzenia udarowe z napędem Wkrętarki z napędem	str. 712 str. 691	
Pomarańczowy 	Wszystkie prace pod napięciem	Nasadki od 6 do 12 mm	Seria „Radio” 1/4"	str. 803
		Nasadki od 9 do 19 mm	Seria „Junior” 3/8"	str. 804
		Nasadki od 8 do 22 mm	Seria standardowa 1/2"	str. 806
Miedź-beryl 	Do prac w otoczeniu wybuchowym	Patrz seria ADF		str. 745

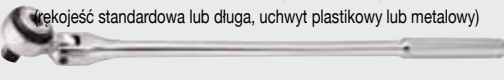
DOBÓR GRZECHOTKI

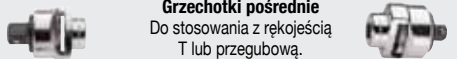
ZASTOSOWANIE	OFERTA	INNE ZALETY	
Uniwersalne	<p>Grzechotki „szczelne”</p> <p>Najwyższa jakość: szczelna grzechotka umożliwia pracę nawet w otoczeniach najbardziej agresywnych.</p> 	Bardzo kompaktowe Precyzyjne „Na docisk dłonią”	Zabierak kwadratowy: 1/4"-3/8"-1/2" RL.161 JL.161 SL.161
	<p>Grzechotka „na docisk dłonią”</p> <p>Tradycja FACOM Zmiana kierunku za pomocą pierścienia Precyzyjna grzechotka umożliwiająca silne dokręcanie/odkręcanie stosując mocny docisk głowicy grzechotki.</p> 	Precyzyjne	Zabierak kwadratowy: 1/4"-3/8"-1/2" R.161 J.161 S.161
	<p>Grzechotki „standardowe”</p> <p>Klasyczna linia z odwracaniem kierunku głowicą.</p> 		Zabierak kwadratowy: 1/4"-3/8"-1/2"-3/4"-1" R.151 - J.151 - S.151 K.152 - K.149 - K.154B M.151
Szybkość i wydajność	<p>Grzechotki szybkie z rękojścią obrotową</p> <p>Szybsza praca w szczególności w ciasnej przestrzeni.</p> 	Blokada nasadki „Na docisk dłonią”	Zabierak kwadratowy: 1/4" - 3/8" - 1/2" R.360 J.360 S.360
Siła / obniżenie wysiłku	<p>Grzechotki długie</p> <p>Mniejsze zmęczenie podczas prac wymagających wysokich momentów dokręcania.</p> 		Zabierak kwadratowy: 3/8"-1/2"-3/4"-1" J.174 - S.154 K.154B K.151B + K.126A M.151 + M.126
	<p>Grzechotki długie przegubowe</p> <p>Połączenie przegubu zapewniającego lepszy dostęp z długą rękojścią zmniejszającą wysiłek i zmęczenie podczas prac wymagających zastosowania wysokich momentów dokręcania (rękojeść z uchwytem plastikowym lub metalowym).</p> 	„Na docisk dłonią”	Zabierak kwadratowy: 3/8"-1/2" J.153A S.153A J.158A S.158A
Blokada nasadek i akcesoriów	<p>Zabezpieczenie nasadek i akcesoriów zapobiegające ryzyku upadku, szczególnie w strefach o utrudnionym dostępie.</p> 	„Na docisk dłonią”	Zabierak kwadratowy: 1/4" - 3/8" - 1/2" R.360 - J.360 S.360 - J.171 J.174 - S.171
Dostępność	<p>Grzechotki z głowicą przegubową</p> <p>(rękojeść standardowa lub długa, uchwyt plastikowy lub metalowy)</p> 	„Na docisk dłonią”	Zabierak kwadratowy: 1/4" - 3/8" - 1/2" S.143A - S.153A S.158A - J.153A J.158A - R.158A
	<p>Grzechotka ultrakompaktowa do końcówek</p> <p>Koncepcja przestudiowana w celu 2-krotnego zmniejszenia wymiarów w stosunku do grzechotki standardowej.</p> 	Umożliwia stosowanie również nasadek z przejściówką ECR	Zabierak kwadratowy: 1/4" R.PE Zabierak kwadratowy: 1/4" + 5/16" 65.PE
	<p>Grzechotka bez rękojeści</p> <p>umożliwiająca założenie ręczne z przedłużką lub bez w ograniczonej przestrzeni</p> 		Zabierak kwadratowy: 1/4" R.150A
Inne	<p>Grzechotki pośrednie</p> <p>Do stosowania z rękojścią T lub przegubową.</p> 		Zabierak kwadratowy: 3/8" - 1/2" J.156 S.156



GRZECHOTKI SZCZELNE

RL-JL-SL.161

SZCZELNOŚĆ I SOLIDNOŚĆ

MECHANIZM ULTRA-WYTRZYMAŁY I SZCZELNY, ZAPEWNIĄCY WIĘKSZĄ TRWAŁOŚĆ

- Podwójna uszczelka: szczelność na pyły przemysłowe.
- Nie wymaga żadnej konserwacji.
- Testowana w warunkach agresywnych.



GŁOWICA ULTRA-KOMPAKTOWA



38 mm w wersji 1/2"



37 mm w wersji 1/2"

WYSOKA DOKŁADNOŚĆ

- 72 zęby o skoku 5°

ZMNIJSZONY WYSIŁEK:

- Grzechotka 1/2" lżejsza (-15% dla S.161, -25% dla grzechotek 1/2" o kierunku odwracającym tradycyjną dźwignią).
- Środek ciężkości przesunięty w kierunku głowicy ułatwiający przekładanie.



SYSTEM „NA DOCISK DŁONIĄ”

- Silniejsze odkręcanie.

ODWRACANIE KIERUNKU UŁATWIONE DZIĘKI WBUDOWANEJ DŹWIGNI.

Brak ryzyka przypadkowego odwrócenia kierunku, nawet przy dłoniach zabrudzonych smarem lub w rękawicach.



KOMFORT UŻYTKOWANIA:

Ciągłość pomiędzy elementami metalowymi i plastikowymi.

OCZKO DO ZAWIESZANIA.

 Zabierak kwadratowy

RL.161 1/4"

JL.161 3/8"

SL.161 1/2"



GRZECHOTKA SZYBKA Z RĘKOJĘCIĄ OBROTOWĄ

PRACUJ 2 RAZY SZYBCIEJ DZIĘKI RĘKOJĘCI OBROTOWEJ

- Rękojeść obrotowa umożliwia szybsze zakładanie bez strat czasu na ruchy tam i z powrotem.
- Zyskujesz czas, przede wszystkim w ograniczonej przestrzeni.

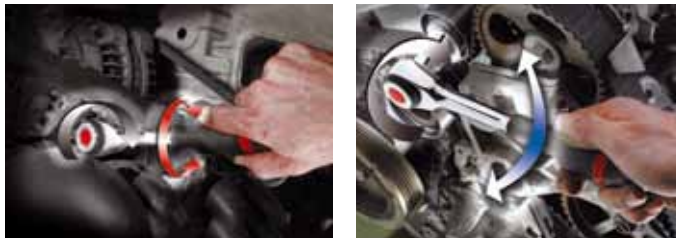

MAKSYMALNY KOMFORT

- Nie ma potrzeby przytrzymywania nasadki podczas zakładania = wystarczy umieścić nasadkę na ekranie i przekręcić rękojeść.
- Zyskujesz na komforcie i dostępności, przede wszystkim w ograniczonej przestrzeni.

BŁOKADA NASADKI

- Nie ma już potrzeby hamowania nasadki dłonią podczas dokręcania gwintów lub nakrętek luźnych.

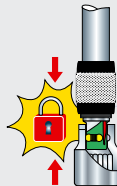

„NA DOCISK DŁONIĄ”

- Możliwość dociskania głowicy grzechotki dla uzyskania większej siły odkręcania/dokręcania.



	Zabierak kwadratowy
R.360	1/4"
J.360	3/8"
S.360	1/2"

- Dostępne również w skrzynkach NANO i DETECTION BOX.

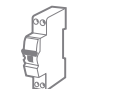
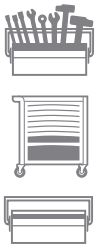

GRZECHOTKI I AKCESORIA Z BLOKADĄ ZABEZPIEZAJĄCĄ

FACOM oferuje asortyment grzechotek i akcesoriów od 1/4" do 1/2" z mechanizmem blokady, gwarantującym uniknięcie ryzyka odblokowania nasadek w trakcie pracy.

Mechanizm blokady

odporność na siłę ciągnięcia - ponad 60 kg, brak ryzyka odblokowania/zerwania nasadki.

Natychmiastowe odblokowywanie dzięki

radelkowanemu pierścieniowi przedłużaczy, przyciskowi odblokowania grzechotki umożliwiającemu natychmiastowe zdjęcie nasadki po naciśnięciu, nawet przy śliskich rękach.

Grzechotki	Przedłużki	Zabierak kwadratowy
R.360	R.210RC R.215RC R.217RC	1/4"
J.360 J.171 J.174	J.210RC J.215RC J.217RC	3/8"
S.360 S.171	S.210RC S.215RC S.217RC	1/2"

Dla bezpieczeństwa należy używać grzechotek i akcesoriów z nasadkami wyposażonymi w rowek z kulką.

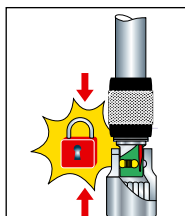

Mechanizm blokady



S.171



Natychmiastowe odblokowywanie

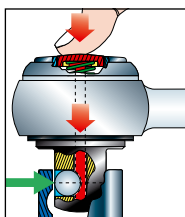

Nasadki wyposażone w rowek z kulką

PROFIL OGV® FACOM

PROFIL OGV® FACOM

- Większa siła podczas odkręcania.
- Większe bezpieczeństwo dzięki znacznemu ograniczeniu ryzyka przeskoczenia, szczególnie na nakrętkach zaokrąglonych.

Profil klasyczny

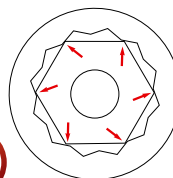

Sily w narożnikach

Profil OGV®

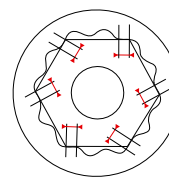

Oparcie na ściankach bocznych

GRZECHOTKA ULTRA-KOMPAKTOWA DO KOŃCÓWEK

GRZECHOTKA FACOM R.PE ZOSTAŁA OPRACOWANA W CELU ZAPEWNIENIA MAKSYMALNEJ SIŁY I MAŁYCH WYMIARÓW PODCZAS UŻYWANIA KOŃCÓWEK.

MAKSYMALNA KOMPAKTOWOŚĆ

Koncepcja R.PE umożliwia włożenie końcówki do mechanizmu i 2-krotne zmniejszenie wysokości w stosunku do grzechotki standardowej. Dzięki temu grzechotka o tym poziomie parametrów jest najbardziej kompaktowa na rynku.



KOMPATYBILNA Z NASADKAMI 1/4"

Dzięki łącznikowi ECR.



PRACUJ SZYBCIEJ

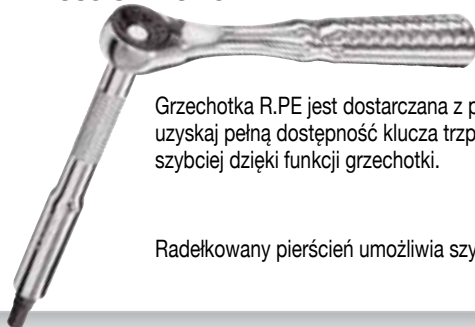

Grzechotka R.PE jest dostarczana z przedłużką 100 mm: uzyskaj pełną dostępność klucza trzpieniowego i pracuj szybciej dzięki funkcji grzechotki.

Radełkowany pierścień umożliwia szybsze zakładanie.

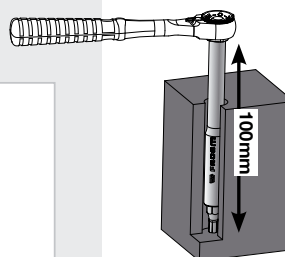

ZESTAW Z GRZECHOTKĄ R.PE I KOŃCÓWKAMI

ULTRA-KOMPLETNA

Końcówki Torx:® od T6 do T40.
Końcówki sześciokątne: od 1,5 mm do 8 mm.
Końcówki PH n°1 - 2 - 3 / PE n°1 - 2 - 3 / płaskie 4 - 5,5 mm. Przejściówka do nasadek
Przedłużka 100 mm.

ULTRA-KOMPAKTOWA

• 124 mm x 34 mm x 64 mm

PRAKTYCZNA

Szybki wybór narzędzi.
Łatwe chwytywanie narzędzi.
Przeciwoślizgowa.

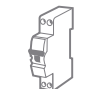

PRZECHOWYWANIE NASADEK

ROZWIĄZANIA DO PRZECHOWYWANIA NASADEK SĄ DOSTOSOWANE DO POTRZEB PRACY PRZENOŚNEJ W WARSZTACIE I DO WYMOGÓW BEZPIECZEŃSTWA.

KOMPAKTOWOŚĆ

**PRACE
RUCHOME**

Koncepcja NANO Box

• Zabierak kwadratowy: 1/4".



**Koncepcja
DETECTION Box**

• Zabierak kwadratowy: 1/2" - 3/8".



Kompatybilność FOD.

**Skrzynki z polipropylenu
lub metalowe**

• Zabierak kwadratowy: 1/4" - 3/8" - 1/2" - 3/4" - 1".



Moduły plastikowe

• Zabierak kwadratowy: 1/4" - 3/8" - 1/2" - 3/4".



MOD.J1

Moduły piankowe

• Zabierak kwadratowy: 1/4" - 3/8" - 1/2".



MODM.R1A

Kompatybilność FOD.

**PRACA
W WARSZTACIE**

**BEZPIECZEŃSTWO
I
WYDAJNOŚĆ**

KONCEPCJA RNANO

ULTRA-KOMPLETNE: 100% ODKRĘCANIA-DOKRĘCANIA

- Do 38 narzędzi, zabierak kwadratowy 1/4", o wymiarach metrycznych lub calowych, z nasadkami sześciokątnymi lub dwunastokątnymi, z grzechotkami standardowymi/szczelnymi/szybkimi.

ULTRA-KOMPAKTOWE

- 50% bardziej kompaktowe niż zestawy 1/4" w skrzynce tradycyjnej.

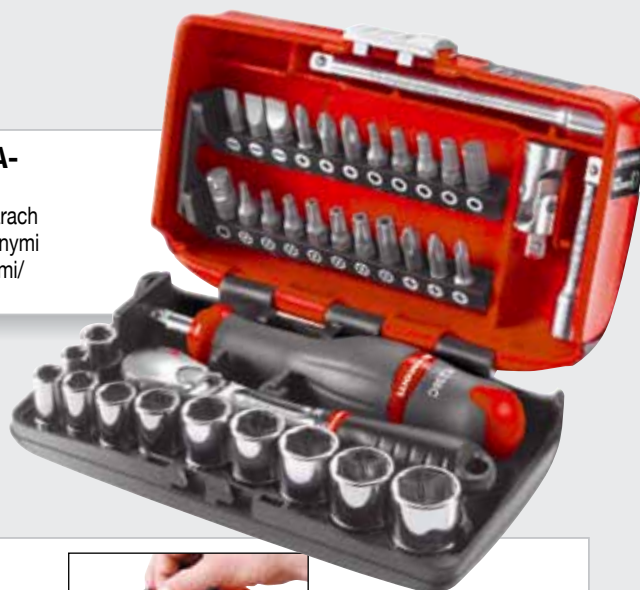

PRAKTYCZNE: ZYSKAJ NA CZASIE

Szybki wybór skrzynki i narzędzi

- dzięki znakowaniu miejsc na narzędzia,
- dzięki nalepce identyfikacyjnej skrzynki na 3 bokach.



Łatwe chwytanie narzędzi

- automatyczne "podnoszenie się" etykiet końcówek podczas otwierania skrzynki.



- chwyt nasadek przez przechylenie.



- samozamykający zatrzask: natychmiastowe zamykanie



W razie przewrócenia, nasadki, końcówki i akcesoria utrzymują się w gniazdach kasety.



WYTRZYMAŁOŚĆ I KOMFORT UŻYTKOWANIA FACOM

- Solidny system zamykania: metalowe zatrzaski i trzpienie zawiasów
- Obudowa z dwóch materiałów: - szkielet skrzynki z PC/B > sztywny i niełamliwy.
- powłoka z TPU = miękka i przeciwpoślizgowa > Dobry chwyt ręką
> Nie ślizga się na powierzchni roboczej
> Nie rysuje miejsca prac (nadwozia itp.)
- Plastik odporny na rozpuszczalniki warsztatowe.



KONCEPCJA DETECTION BOX

ZWIĘKSZONE BEZPIECZEŃSTWO

- Koncepcja „Detection BOX” umożliwia natychmiastową inwentaryzację, nawet jeżeli skrzynka jest zamknięta.



ŁATWE PRZECHOWYWANIE

- Mieści się we wszystkich szufladach wózka (również w szufladach o wysokości 60 mm).
- Zajmuje szerokość modułu „1/3” wózka.
- Utrzymuje się w położeniu pionowym.
- Nie ślizga się, nawet na śliskim podłożu.



ŁATWE PRZENOSZENIE

- Dzięki przedłużce, która stanowi uchwyt.

PRAKTYCZNA

- Nasadki są mocno utrzymywane w gniazdach i pozostają na miejscu, nawet jeżeli skrzynka się przewróci.













WYSOKA WYTRZYMAŁOŚĆ

- Dzięki obudowie z dwóch materiałów, metalowym zatrzaskom i trzpieniom zawiasów.



ZESTAWY NASADEK 1/4" NANO

WYMIARY METRYCZNE

		RL.NANO1	RL.NANO112	R.360NANO	R2NANO	
		RL.161	RL.161	R.360	R.161	
		6	12	6	6	
∇ 1/4" 6,35 mm		1/4"	1/4"	1/4"	1/4"	
	5,5	•	•	•	•	
	6	•	•	•	•	
	7	•	•	•	•	
	8	•	•	•	•	
	9	•	•	•	•	
	10	•	•	•	•	
	11	•	•	•	•	
	12	•	•	•	•	
	EP	•	•	•	•	
	1	•	•	•	•	
		•	•	•	•	
	2	•	•	•	•	
	3	•	•	•	•	
		EH	•	•	•	•
		3	•	•	•	•
		•	•	•	•	
4		•	•	•	•	
	5	•	•	•	•	
	6	•	•	•	•	
	7	•	•	•	•	
	ED	•	•	•	•	
	1	•	•	•	•	
		•	•	•	•	
	ES	•	•	•	•	
	4,5	•	•	•	•	
		•	•	•	•	
	6,5	•	•	•	•	
	8	•	•	•	•	
	EXR	•	•	•	•	
	10	•	•	•	•	
		•	•	•	•	
	15	•	•	•	•	
	20	•	•	•	•	
	25	•	•	•	•	
	27	•	•	•	•	
	30	•	•	•	•	
40	•	•	•	•		
	R.209	•	•	•	•	
	R.210	•	•	•	•	
		•	•	•	•	
	R.240A	•	•	•	•	
	R.235	•	•	•	•	
	R.236A	•	•	•	•	
	ECR	•	•	•	•	
BV.NANO1						
152 x 48 x 92 mm						
		0,81 Kg	0,745 Kg	0,85 Kg	0,85 Kg	

RL.NANO1



RL.NANO112



R.360NANO

























R2NANO



ZESTAWY NASADEK 1/4" NANO

WYMIARY CALOWE

		RL.NANO-U1	RL.NANO-U112	RL.NANO-U2	R.360NANO-U1	R.360NANO-U112
		RL.161	RL.161	RL.161	R.360	R.360
		1/4"	1/4"	1/4"	1/4"	1/4"
	1/4" 6,35 mm					
	7/32	•	•	•	•	•
	1/4	•	•	•	•	•
	9/32	•	•	•	•	•
	5/16	•	•	•	•	•
	11/32	•	•	•	•	•
	3/8	•	•	•	•	•
	13/32	•	•	•	•	•
	7/16	•	•	•	•	•
	1/2	•	•	•	•	•
9/16	•	•	•	•	•	
	EP	1		•	•	
		2		•	•	
		3		•	•	
	EH	1/4	•	•	•	•
		1/8	•	•	•	•
		3/16	•	•	•	•
	"	5/32	•	•	•	•
	7/32	•	•	•	•	
	ED	1	•	•	•	•
		2	•	•	•	•
		3	•	•	•	•
	ES	4,5	•	•	•	•
		6,5	•	•	•	•
		8	•	•	•	•
	TORX®	8		•	•	
	EXR	10	•	•	•	•
		15	•	•	•	•
		20	•	•	•	•
		25	•	•	•	•
		27	•	•	•	•
		30	•	•	•	•
		40	•	•	•	•
	R.209	•	•	•	•	•
		R.210	•	•	•	•
		R.240A	•	•	•	•
		R.235	•	•	•	•
		R.236C	•	•	•	•
	ECR	•			•	
		BV.RNANO-U				
		152 x 48 x 92 mm				
		0,81 Kg	0,745 Kg	0,81 Kg	0,90 Kg	0,85 Kg

RL.NANO-U1



RL.NANO-U112



RL.NANO-U2



R.360NANO-U1





























R.360NANO-U112



ZESTAWY NASADEK 1/4" KLASYCZNE

WYMIARY METRYCZNE

	R.3A	R.410AE	R.410D	R.420P	R.425AP	R.426AP	R.425A
	R.161	R.151	R.151	R.161	R.161	R.161	R.151
	1/4"	1/4"	1/4"	1/4"	1/4"	1/4"	1/4"
 mm	3,2			•			
	4			•			
	5	•		•			
	5,5	•	•	•	•	•	•
	6	•	•	•	•	•	•
	7	•	•	•	•	•	•
	8	•	•	•	•	•	•
	9	•	•	•	•	•	•
	10	•	•	•	•	•	•
	11	•	•	•	•	•	•
	12	•	•	•	•	•	•
	13	•	•	•	•	•	•
	14			•			
 EP	1				•	•	•
	2				•	•	•
	3						
 EH	3				•	•	•
	4				•	•	•
	5				•	•	•
 mm	6				•	•	•
	7						
	8						
 ED	1	•					
	2	•					
	3	•					
 ES	4				•	•	•
	4,5						
	5,5						
	6,5				•	•	•
	8				•	•	•
 EXR	10						
	15	•					
	20	•					
	25	•					
	27						
	30	•					
	40	•					
	R.209			•	•	•	•
	R.210	•	•	•	•	•	•
	R.215			•	•	•	•
	R.240A			•	•	•	•
	R.235	•					
	R.236A	•	•	•	•	•	•
	R.120A			•	•	•	•
	R.222			•	•	•	•
	R.142						
	PL.366A	PL.390A	PL.244A	PL.442		PL.441	
				BP.102			
				204 x 122 x 52 mm			
	0,60 Kg	0,55 Kg	0,66 Kg	0,82 Kg		0,83 Kg	

R.3A ▼



R.410AE ▼



R.410D ▼



R.420P ▼





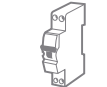



















R.425AP ▼
R.426AP ▼
R.425A ▼



ZESTAWY NASADEK 1/4" KLASYCZNE MIESZANE

WYMIARY METRYCZNE/CALOWE

		R.411MU	R.420MU
  1/4" 6,35 mm		R.151 1/4"	RL.161 1/4"
 mm	3,2		•
	4	•	•
	5	•	•
	5,5	•	•
	6	•	•
	7	•	•
	8	•	•
	9	•	•
	10	•	•
	11	•	•
	12	•	•
	13	•	•
	14		
	 "	3/16	
7/32		•	•
1/4		•	•
9/32		•	•
5/16		•	•
11/32		•	•
3/8		•	•
13/32		•	•
7/16		•	•
1/2		•	•
9/16	•	•	
 EH  mm	3		
	4		
	5		
	6		
	7		
 ED 	1		
	2		
	3		
 ES 	4		
	4,5		
	5,5		
	6,5		
 EXR 	10		
	15		
	20		
	25		
	27		
	30		
	40		
       	R.209	•	•
	R.210		
	R.215	•	•
	R.240A	•	•
	R.235		
	R.236A		•
	R.120A		•
	R.222	•	
	R.142	•	
 	PL.125A		PL.453
	BP.115		BP.102
	332 x 143 x 67 mm		204 x 122 x 52 mm
	1,56 Kg		0,72 Kg

R.411MU



R.420MU



ZESTAWY NASADEK 1/4" KLASYCZNE MIESZANE

WYMIARY METRYCZNE/CALOWE/KLUCZE

			R.440UP	R.418AU	R.450AP	R.440EP	R.447EP	R.430AP
			R.161	R.151	R.161	R.161	R.161	R.161
			mm+klucze	mm	std+dlugie	mm+klucze	mm+klucze	mm
 1/4" 6,35 mm	 mm	3,2	•	•	•	•	•	•
		4	•	•	•	•	•	•
		5	•	•	•	•	•	•
		5,5	•	•	•	•	•	•
		6	•	•	•	•	•	•
		7	•	•	•	•	•	•
		8	•	•	•	•	•	•
		9	•	•	•	•	•	•
		10	•	•	•	•	•	•
		11	•	•	•	•	•	•
		12	•	•	•	•	•	•
		13	•	•	•	•	•	•
		14	•	•	•	•	•	•
		 34	 głowica pochylona pod kątem 15° i 75°	3/2	•			
4	•							
5	•							
5,5	•							
6	•							
7	•							
8	•							
9	•							
10	•							
11	•							
12	•							
13	•							
14	•							
 ED	 +			1			•	
		2						•
		3						•
		4						•
 EH	 mm	2,5					•	
		3						•
		4						•
		5						•
		6						•
		7						•
		8						•
		8						•
 ES		3			•		•	
		4						•
		5,5						•
		6,5						•
 RT		3			•		•	
		4						•
		5						•
		7						•
 22	 3,2 x 5,5 4 x 5 6 x 7 8 x 9 10 x 11 12 x 13						•	
								•
								•
								•
								•
								•
 R.209 R.210S R.215 R.240A R.235 R.245 R.236A R.120A R.110 R.140A R.216 R.227 181.18G AN 2,5 x 75 AN 3,5 x 75		•		•	•	•	•	
		•	•					
		•						
		•						
		•	•					
		•						
		•						
		•						
		•						
		•						
		•						
		•						
		•						
		•						
			PL.37A BP.109	PL.391B BP.102	PL.703	PL.36A BP.109	PL.128A	PL.414
			478x234x72 mm	204x122x52 mm		478x234x72 mm		
			2,56 Kg	0,55 Kg	3,26 Kg	2,70 Kg	2,50 Kg	1,92 Kg

R.440UP ▼



R.418AU ▼



R.450AP ▼



R.440EP ▼



R.447EP ▼





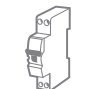
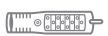

R.430AP ▼



ZESTAWY NASADEK 1/4"

W KASETACH LUB NA SZYNACH

 TORX® 1/4" 6,35 mm		R.40E	RL.40E	RL.41E	R.40U	REL.40U	RTX.40
		Standard	Długie	Długie	Standard	Długie	TORX® TORX®
 mm	3,2	•	•				
	4	•	•				
	5	•	•				
	5,5	•	•				
	6	•	•				
	7	•	•				
	8	•	•				
	9	•	•				
	10	•		•			
	11	•		•			
	12	•		•			
	13	•		•			
	14	•		•			
	 "	3/16				•	•
7/32					•	•	
1/4					•	•	
9/32					•	•	
5/16					•	•	
11/32					•	•	
3/8					•	•	
13/32					•	•	
7/16					•	•	
1/2					•	•	
9/16				•	•		
 TORX®	E4						•
	E5						•
	E6						•
	E7						•
	E8						•
	E10						•
		CKS.93 0,255 Kg	CKS.89 0,220 Kg	CKS.89 0,310 Kg	CKS.93 0,235 Kg	CKS.93 0,345 Kg	CKS.89 0,090 Kg

**R.40E
RL.40E**



RL.41E



R.40U















REL.40U



RTX.40



MODUŁY 1/4" WKŁADKI TERMOFORMOWANE METRYCZNE I CALOWE

		MOD.RL1	MOD.R1	MOD.R5	MOD.R3	
		RL.161	R.161	R.161	R.161	
		6 mm	6 mm	6 mm	6 "	
 1/4" 6,35 mm	3,2	3/16"				
	4	7/32"				
	5	1/4"				
	5,5	9/32"	•	•	•	
	6	5/16"	•	•	•	
	7	11/32"	•	•	•	
	8	3/8"	•	•	•	
	9	13/32"	•	•	•	
	10	7/16"	•	•	•	
	11	1/2"	•	•	•	
	12	-	•	•	•	
	13	-	•	•	•	
	14	-	•	•	•	
	 EP	1				
2						
3						
 EH	1/8					
	3/16					
	5/32					
	7/32					
 EH	3	•	•	•		
	4	•	•	•		
	5	•	•	•		
	6	•	•	•		
	7	•	•	•		
 ED	ED.101T	•	•	•		
	ED.102T	•	•	•		
 ES	4,5	•	•	•		
	6,5	•	•	•		
	8	•	•	•		
 EXR	10			•		
	15			•		
	20			•		
	25			•		
	30			•		
	40			•		
 82H	2	•	•	•		
	2,5	•	•	•		
	3	•	•	•		
	4	•	•	•		
	5	•	•	•		
	6	•	•	•		
	7	•	•	•		
	8	•	•	•		
	9	•	•	•		
	10	•	•	•		
 83SH	1,5			•		
	2			•		
	2,5			•		
	3			•		
	4			•		
	5			•		
	6			•		
	8			•		
	10			•		
 89S	10			•		
	15			•		
	20			•		
	25			•		
	27			•		
	30			•		
	40			•		
	45			•		
	 R.209 R.215 R.240A R.235 R.236A R.120A		•	•	•	•
			•	•	•	•
		•	•	•	•	
		•	•	•	•	
		•	•	•	•	
		•	•	•	•	
	PL.321	PL.321	PL.658	PL.603		
	435 x 198 x 55 mm	420 x 180 x 55 mm	420 x 190 x 55 mm	420 x 180 x 55 mm		
		1,1 Kg	1,41 Kg	0,95 Kg		

MOD.RL1



MOD.R1















MOD.R5

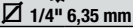

MOD.R3



MODUŁY 1/4" WKŁADKI PIANKOWE DWUKOLOROWE-METRYCZNE

			MODM.RL1	MODM.R1A
			RL.161	R.161
				
			1/4"	1/4"
	mm	5,5	•	•
		6	•	•
		7	•	•
		8	•	•
		9	•	•
		10	•	•
		11	•	•
		12	•	•
		13	•	•
		14	•	•
	EP	EP.101T	•	•
		EP.102T	•	•
		EP.103T	•	•
	EH	EH.103	•	•
		EH.104	•	•
		EH.105	•	•
		EH.106	•	•
		EH.107	•	•
	ED	ED.101T	•	•
		ED.102T	•	•
		ED.103T	•	•
	ES	ES.134,5T	•	•
		ES.136,5T	•	•
		ES.148T	•	•
	EXR	EXR.115	•	•
		EXR.120	•	•
		EXR.125	•	•
		EXR.127	•	•
		EXR.130	•	•
		EXR.140	•	•
	83SH	1,5	•	•
		2	•	•
		2,5	•	•
		3	•	•
		4	•	•
		5	•	•
		6	•	•
		8	•	•
		10	•	•
	R.209	R.209	•	•
		R.215	•	•
		R.240A	•	•
		R.235	•	•
		R.236A	•	•
		R.120A	•	•
			PM.MODR1A	PM.MODR1A
			416 x 190 x 50 mm	420 x 190 x 55 mm
			1,095 Kg	

MODM.RL1



MODM.R1A

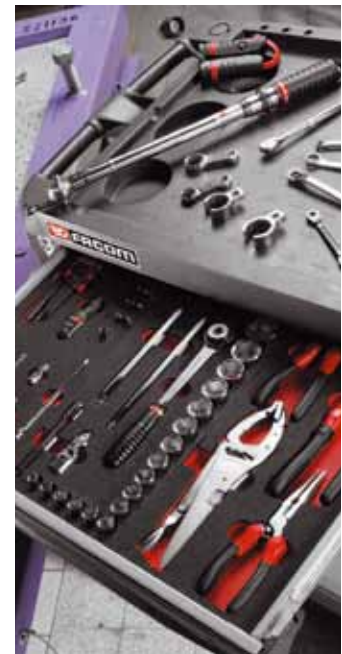

Grzechotki 1/4"

Grzechotka 1/4" szczelna o wysokich parametrach

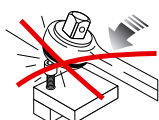
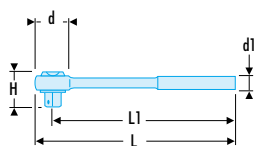

NF ISO 3315, ISO 3315, DIN 3122, ASME B107.10

- Bardzo wysoka trwałość bez konserwacji, niezależnie od warunków pracy.
- Szczelność na pyły, szlamy przemysłowe itp.
- Mechanizm z 72 zębami i skokiem co 5°.
- Odwracanie kierunku za pomocą dźwigni umożliwiającej wzrokową kontrolę kierunku obrotów.
- System „na docisk dłonią”, umożliwiający dociskanie główki grzechotki podczas dokręcania i odkręcania bez ryzyka przypadkowego odwrócenia kierunku obrotów.
- Główka ultra-kompaktowa.
- Oczko do zaczepiania do prac na wysokości.
- Wyjątkowa wygoda.

	d [mm]	d1 [mm]	H [mm]	L [mm]	L1 [mm]	ΔΔ [g]
RL.161	22	20	25	120	110	78

Grzechotka 1/4" szybka z rękojeścią obrotową

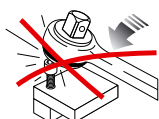
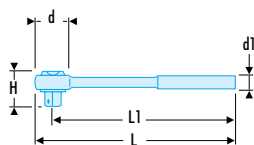

NF ISO 3315, ISO 3315, DIN 3122, ASME B107.10

- Mechanizm z rękojeścią obrotową: praca dwukrotnie szybsza nawet w miejscach o utrudnionym dostępie.
- Skok 6°.
- Blokada bezpieczeństwa nasadki: zapobiega zagubieniu nasadki w maszynach.
- System „na docisk dłonią”, umożliwiający dociskanie główki grzechotki podczas dokręcania i odkręcania bez ryzyka przypadkowego odwrócenia kierunku obrotów.

	d [mm]	d1 [mm]	H [mm]	L [mm]	L1 [mm]	ΔΔ [g]
R.360	27	21	29	120	120	144

Grzechotka 1/4" „na docisk dłonią”.

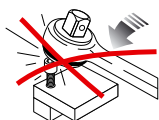
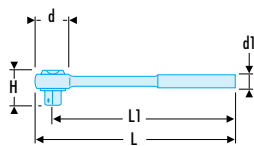

NF ISO 3315, ISO 3315, DIN 3122, ASME B107.10

- Mechanizm z 72 zębami o skoku 5°.
- System „na docisk dłonią”, umożliwiający dociskanie główki grzechotki podczas dokręcania i odkręcania bez ryzyka przypadkowego odwrócenia kierunku obrotów.
- Odwracanie kierunku za pomocą pierścienia.

	d [mm]	d1 [mm]	H [mm]	L [mm]	L1 [mm]	ΔΔ [g]
R.161	25	19	25	120	108	120



Grzechotka 1/4" klasyczna

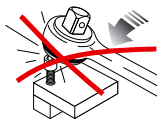
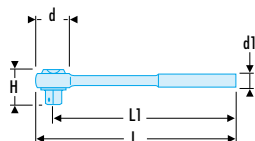

NF ISO 3315, ISO 3315, DIN 3122, ASME B107.10

- Mechanizm z 72 zębami o skoku 5°.
- Odwracanie kierunku za pomocą kołpaka obrotowego.

⇒	d [mm]	d1 [mm]	H [mm]	L [mm]	L1 [mm]	ΔΔ [g]
R.151	25	21	25	120	108	100

Grzechotka 1/4" ultra-kompaktowa do końcówek 1/4"

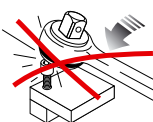
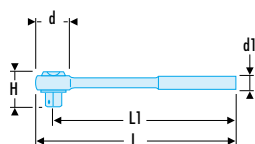

- Jej budowa zapewnia wyjątkową kompaktowość podczas korzystania z końcówek.
- Mechanizm: 60 zębów.
- Praca z nasadkami, dzięki łącznikowi ECR.
- Dostarczana z przedłużaczem magnetycznym.

⇒	d [mm]	d1 [mm]	H [mm]	L [mm]	L1 [mm]	ΔΔ [g]
R.PE	17	16	26,5	158	126	96

65.PE Klucz grzechotkowy z uchwytem do końcówek - zabierak 1/4" - 5/16"



- Możliwość mocowania końcówek:
 - Seria 1: zabierak 6-kątny 1/4".
 - Seria 2: zabierak 6-kątny 5/16".
- Nadaje się do montażu mocowań stosowanych w lotnictwie 1/4" i 5/16".
- Skok zęba grzechotki: 5°.
- Głównki odchylone o 15°.
- Mocowanie końcówki za pomocą pierścienia metalowego.
- Głównka radełkowana do szybkiego dokręcania.
- Długość: 150 mm.
- Wykończenie: chromowane satynowane.
- Masa: 74 g.

Grzechotka 1/4" bez rękojści

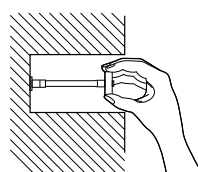
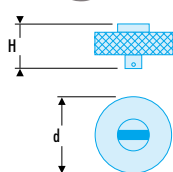

- Mechanizm z 72 zębami o skoku 5°.
- Idealna do dostępu do ciasnych gniazd.

⇒	d [mm]	H [mm]	ΔΔ [g]
R.150A	38,5	26,5	95

Grzechotka 1/4" długa przegubowa z rękojścią metalową

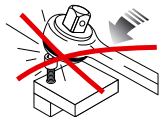
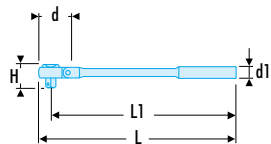

- Mechanizm z 72 zębami o skoku 5°.
- System „na docisk dłonią”, umożliwiający dociskanie główki grzechotki podczas dokręcania i odkręcania bez ryzyka przypadkowego odwrócenia kierunku obrotów.
- Przegub hamowany umożliwiający zachowanie położenia nawet z założonym przedłużaczem i nasadką.
- Rękojeść metalowa radełkowana.

	d [mm]	d1 [mm]	H [mm]	L [mm]	L1 [mm]	ΔΔ [g]
R.158A	25	11	26,5	158	126	135

KONSERWACJA GRZECHOTEK 1/4"

	R.161	R.151	R.155A	R.157A	R.158A	R.150A
Nakładki						
 R.161C J.161C R.151C	•		•	•	•	•
Zestaw części zamiennych						
 R.161RN R.151RN	•	•	•	•	•	•
Zabieraki						
 R.151R	•	•	•	•	•	•

Akcesoria 1/4"

Rękojeść przesuwna 1/4"

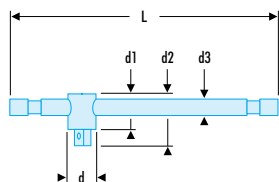

NF ISO 3315, ISO 3315, DIN 3122, ASME B107.10

- Hamulec umieszczony na główce podtrzymuje położenie trzpienia przesuwnej, który dzięki temu może tworzyć klucz w kształcie T lub L.
- Wykończenie: chromowane błyszczące.

	d [mm]	d1 [mm]	d2 [mm]	d3 [mm]	L [mm]	ΔΔ [g]
R.120A	12	14	22	7	115	49

Rękojeść przegubowa wkrętakowa 1/4"

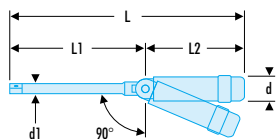

- Rękojeść wkrętakowa lub uchwyt w kształcie L, to narzędzie umożliwia szybkie dojsście lub mocne dokręcenie.

	d [mm]	d1 [mm]	L [mm]	L1 [mm]	L2 [mm]	ΔΔ [g]
R.142	14	8,1	182	105	77	125



▣ Rękojeść przegubowa 1/4"

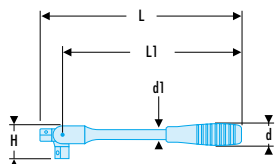

NF ISO 3315, ISO 3315, DIN 3122, ASME B107.10

- Przegub umożliwia manewrowanie narzędziem, nawet w przypadku napotkania przeszkody, a zatrząsk kulkowy hamuje główkę w dowolnej pozycji.
- Uchwyt antypoślizgowy.
- Wykończenie: chromowane błyszczące.

☞	d [mm]	d1 [mm]	H [mm]	L [mm]	L1 [mm]	ΔΔ [g]
R.140A	19	8	25,5	150	131,5	83

▣ R.236C Rękojeść wkrętakowa 1/4" krótka



NF ISO 3315, ISO 3315, DIN 3122, ASME B107.10

- Ergonomiczna rękojeść z dwóch materiałów.
 - Idealna w przypadku trudnego dostępu.
- Masa: 76 g.

▣ R.236A Rękojeść wkrętakowa 1/4" średnia



NF ISO 3315, ISO 3315, DIN 3122, ASME B107.10

- Ergonomiczna rękojeść z dwóch materiałów.
 - Idealna w przypadku trudnego dostępu.
- Masa: 79 g.

▣ Rękojeść wkrętakowa 1/4" długa

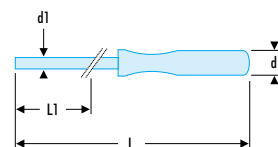

NF ISO 3315, ISO 3315, DIN 3122, ASME B107.10

- Ergonomiczna rękojeść z dwóch materiałów.
- Idealna w przypadku trudnego dostępu.

☞	d [mm]	d1 [mm]	L [mm]	L1 [mm]	ΔΔ [g]
R.227A	23,5	8	260	160	125

▣ Rękojeść wkrętakowa 1/4" giętka

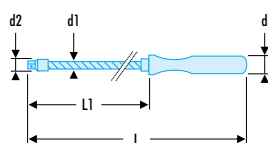

- Ergonomiczna rękojeść z dwóch materiałów.
- Idealna do miejsc trudno dostępnych dzięki giętkiemu grotowi.

☞	d [mm]	d1 [mm]	d2 [mm]	L [mm]	L1 [mm]	ΔΔ [g]
R.222A	20	8	12	265	160	117

Korba 1/4"

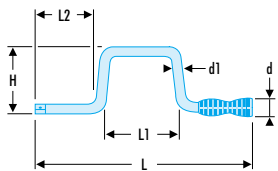

NF ISO 3315, ISO 3315, DIN 3122, ASME B107.10

- Duża szybkość manewrowania.
- Rękojeść obrotowa PCV.
- Wykończenie: chromowane błyszczące.

➤	d [mm]	d1 [mm]	H [mm]	L [mm]	L1 [mm]	L2 [mm]	ΔΔ [g]
R.110	21	8	110	360	130	120	220

R - Przedłużacz 1/4" standardowy

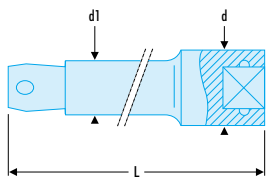

NF ISO 3316, ISO 3316, DIN 3123, ASME B107.10

- Wykończenie: chromowane błyszczące.

➤	d [mm]	d1 [mm]	L [mm]	ΔΔ [g]
R.209	12	8,2	55	30
R.210	12	8,2	100	45
R.215	12	8,2	150	65
R.217	12	8,2	250	105

PRZEDŁUŻACZE KĄTOWE

Element niedostępny za pomocą nasadki lub przegubu?
POMYŚL O PRZEDŁUŻACZU KĄTOWYM!

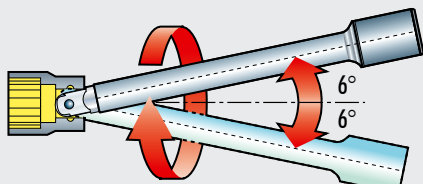

▣ R.S - Przedłużacz 1/4" kątowny

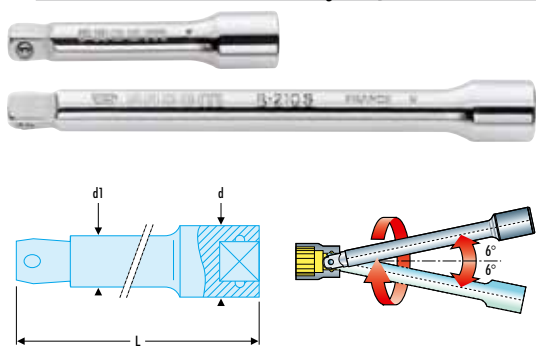

- Kształt zabieraka kwadratowego umożliwia pracę z mimośrodem lub odchyleniem o maks. 6°.
- Zastępuje korzystnie przegub, ponieważ jest bardziej kompaktowy i szybszy.
- Wykończenie: chromowane błyszczące.

☞	d [mm]	d1 [mm]	L [mm]	ΔΔ [g]
R.209S	12	8,2	55	30
R.210S	12	8,2	100	45

▣ R.RC - Przedłużacz 1/4" z blokadą

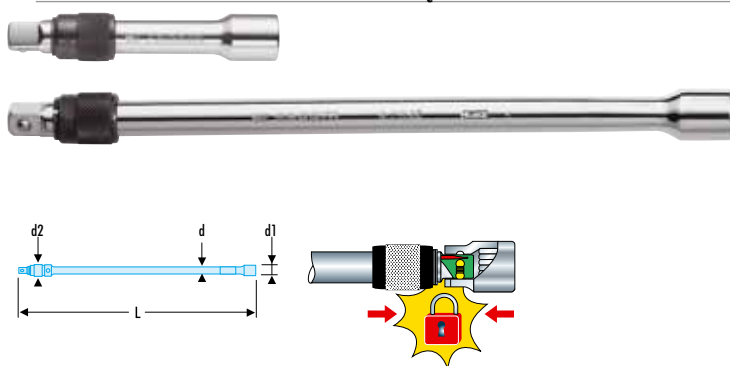

NF ISO 3316, ISO 3316, DIN 3123, ASME B107.10

- Mechanizm blokady nasadki.
- Wykończenie: chromowane błyszczące.

☞	d [mm]	d1 [mm]	d2 [mm]	L [mm]	ΔΔ [g]
R.210RC	8,2	12	13	100	45
R.215RC	8,2	12	13	150	60
R.217RC	8,2	12	13	250	100

▣ Przedłużacz giętki 1/4"

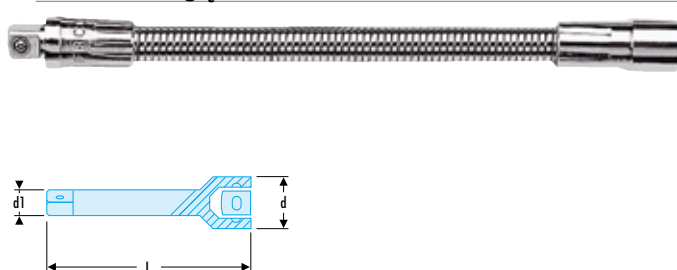

ASME B107.10

- Umożliwia dostęp do nakrętek w trudno dostępnych miejscach.
- Nie może być używany do mocnych dokręceń: 2,8 Nm maks.

☞	d [mm]	d1 [mm]	L [mm]	ΔΔ [g]
R.216	12	8	150	66

▣ Rękojeść z przegubem kardana 1/4"

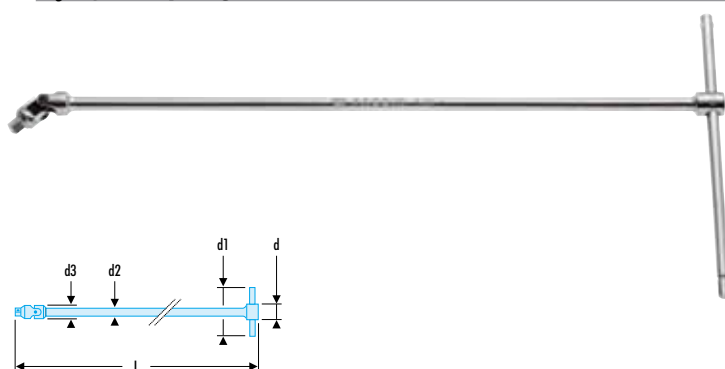

- Przegub przenosi wysokie momenty dokręcania i zapewnia utrzymanie nasadki w stałym położeniu (hamowanie za pomocą sprężyny).
- Dzięki swojej długości i kątowni wychylenia do 65°, klucz ten może być używany do nakrętek w trudno dostępnych miejscach.
- Wykończenie: chromowane błyszczące.

☞	d [mm]	d1 [mm]	d2 [mm]	d3 [mm]	L [mm]	ΔΔ [g]
R.229A	13	135	9	13	385	215

Rękojeść z przegubem kardana 1/4" długa

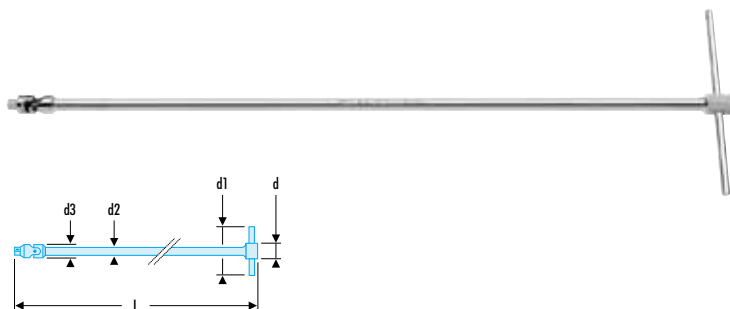

- Rękojeść w formie T umożliwia dostęp do głębokich miejsc dzięki swojej wyjątkowej długości.
- Wykończenie: chromowane błyszczące.

🔧	d [mm]	d1 [mm]	d2 [mm]	d3 [mm]	L [mm]	ΔΔ [g]
R.228	13	135	9	13	470	250

Przegub uniwersalny 1/4"



NF ISO 3316, ISO 3316, DIN 3123, ASME B107.10

- Przegub hamowany za pomocą sprężyn. Pozostaje w położeniu początkowym umożliwiając osiągnięcie miejsca o trudnym dostępie.
- Wykończenie: chromowane błyszczące.

🔧	d [mm]	L [mm]	L1 [mm]	ΔΔ [g]
R.240A	13	33	25	20

Przełożenie 1/4" do 3/8"

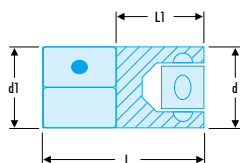

NF ISO 3316, ISO 3316, DIN 3123, ASME B107.10

- Gniazdo 1/4", zabierak kwadratowy 3/8".
- Umożliwia stosowanie nasadek 3/8".
- Wykończenie: chromowane błyszczące.

🔧	d [mm]	d1 [mm]	L [mm]	L1 [mm]	ΔΔ [g]
R.232	12	12	24,5	13,5	16

D.169 Zestaw 3 adapterów



- Rozpórki umożliwiają używanie narzędzi z zabierakiem o wymiarach mniejszych od nasadki:
 - Zabierak 1/4 + D.169RJ nasadka 3/8.
 - Zabierak 3/8 + D.169JS nasadka 1/2.
 - Zabierak 1/2 nasadka 3/4.
- Małe wymiary zewnętrzne pozwalające zredukować ilość narzędzi potrzebnych przy interwencjach serwisowych.
- Mocowanie magnetyczne i blokada (JS i SK).
- Pierścień ryflowany umożliwiający dotarcie do miejsc trudno dostępnych.

Masa: 96 g.



▣ Nasadka z uchwytem do końcówek 1/4"

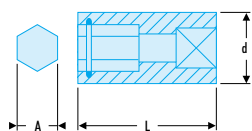

NF ISO 2725-1, NF ISO 1173, ISO 2725-1, ISO 1173, DIN 3124

Z pierścieniem blokującym do końcówek do dokręcania (częsty demontaż).

- Wykończenie: chromowane błyszczące.

⇒	A ["]	Kwadrat ["]	d [mm]	L [mm]	ΔΔ [g]
R.235	1/4	1/4	11,3	22	10

▣ Nasadka z uchwytem do końcówek z pierścieniem 1/4"

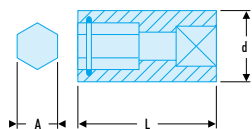

NF ISO 2725-1, NF ISO 1173, ISO 2725-1, ISO 1173, DIN 3124

- Z pierścieniem do mocniejszego blokowania końcówek (do rzadkiego demontażu).

- Końcówka kwadratowa wyposażona w otwór na zatrzask kulkowy lub zaczep.

- Wykończenie: chromowane błyszczące.

⇒	A ["]	Kwadrat ["]	d [mm]	L [mm]	ΔΔ [g]
R.245	1/4	1/4	11,3	22	10

▣ Nasadka z uchwytem do końcówek z pierścieniem ryglującym 1/4"



NF ISO 2725-1, NF ISO 1173, ISO 2725-1, ISO 1173, DIN 3124

- Blokowanie końcówki.

- Końcówka kwadratowa wyposażona w otwór na zatrzask kulkowy lub zaczep.

⇒	A ["]	Kwadrat ["]	L [mm]	ΔΔ [g]
EF.R	1/4	1/4	30	26

Nasadki 1/4"

▣ R - Nasadki 1/4" 6-kątne metryczne

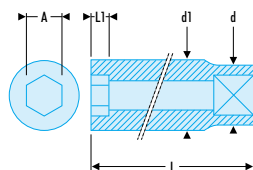

NF ISO 2725-1, NF ISO 1711-1, ISO 2725-1, ISO 1711-1, DIN 3124, ASME B107.5

- Profil OGV®: większa siła i bezpieczeństwo, ochrona nakrętek.

- Wykończenie: chromowane błyszczące.

- Dostępne w zestawie na stojaku metalowym (symbol R.40E).

⇒	A [mm]	⊙ [mm]	d [mm]	d1 [mm]	L [mm]	L1 [mm]	ΔΔ [g]
R.3,2	3,2	6	11,2	5,9	22	2,4	7,30
R.4	4,0	6	11,2	6,9	22	2,6	7,70
R.5	5,0	6	11,2	8,2	22	4,8	8,10
R.5,5	5,5	6	11,2	8,8	22	4,8	8,40
R.6	6,0	6	11,2	9,4	22	5,6	8,60
R.7	7,0	6	11,0	11,0	22	6,0	9,20
R.8	8,0	6	12,0	12,0	22	6,5	11,50
R.9	9,0	6	13,2	13,2	22	6,5	14,30
R.10	10,0	6	14,7	14,7	22	7,8	17,70
R.11	11,0	6	15,8	15,8	22	9,0	19,40
R.12	12,0	6	17,0	17,0	22	9,50	23,20
R.13	13,0	6	17,7	17,7	22	10,00	23,70
R.14	14,0	6	18,7	18,7	22	10,00	26,10

R - Nasadki 1/4" 6-kątnie calowe

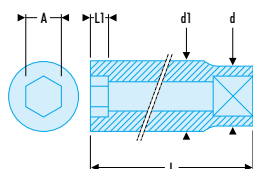

ASME B107.1

- Profil OGV®: większa siła i bezpieczeństwo, ochrona nakrętek.
- Wykończenie: chromowane błyszczące.
- Dostępne w zestawie na stojaku metalowym (symbol R.40U).

➤	A ["]	⊘ [mm]	d [mm]	d1 [mm]	L [mm]	L1 [mm]	ΔΔ [g]
R.3/16	3/16	6	11,2	8,0	22	4,75	8,20
R.7/32	7/32	6	11,2	9,0	22	5,50	8,30
R.1/4	1/4	6	11,2	10,1	22	6,00	9,30
R.9/32	9/32	6	11,0	11,0	22	6,00	8,90
R.5/16	5/16	6	12,0	12,0	22	6,50	11,50
R.11/32	11/32	6	13,2	13,2	22	6,50	14,50
R.3/8	3/8	6	14,7	14,7	22	7,80	17,80
R.13/32	13/32	6	14,7	14,7	22	7,80	17,00
R.7/16	7/16	6	15,8	15,8	22	9,00	19,50
R.1/2	1/2	6	17,7	17,7	22	10,00	24,50
R.9/16	9/16	6	18,7	18,7	22	10,00	25,20

R.E - Nasadki 1/4" 12-kątnie metryczne

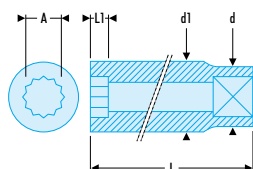

NF ISO 2725-1, NF ISO 1711-1, ISO 2725-1, ISO 1711-1, DIN 3124, ASME B107.5

- Profil OGV®: większa siła i bezpieczeństwo, ochrona nakrętek.
- Wykończenie: chromowane błyszczące.

➤	A [mm]	⊘ [mm]	d [mm]	d1 [mm]	L [mm]	L1 [mm]	ΔΔ [g]
R.5,5E	5,5	12	11,2	8,8	22	4,80	8,40
R.6E	6,0	12	11,2	9,4	22	5,60	8,60
R.7E	7,0	12	11,0	11,0	22	6,00	9,20
R.8E	8,0	12	12,0	12,0	22	6,50	11,50
R.9E	9,0	12	13,2	13,2	22	6,50	14,30
R.10E	10,0	12	14,7	14,7	22	7,80	17,70
R.11E	11,0	12	15,8	15,8	22	9,00	19,40
R.12E	12,0	12	17,0	17,0	22	9,50	23,20
R.13E	13,0	12	17,7	17,7	22	10,00	23,70
R.14E	14,0	12	18,7	18,7	22	10,00	26,10

R.E - Nasadki 1/4" 12-kątnie calowe

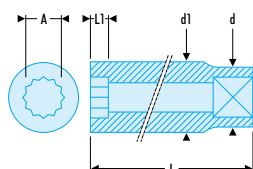

ASME B107.1

- Profil OGV®: większa siła i bezpieczeństwo, ochrona nakrętek.
- Wykończenie: chromowane błyszczące.

➤	A ["]	⊘ [mm]	d [mm]	d1 [mm]	L [mm]	L1 [mm]	ΔΔ [g]
R.3/16E	3/16	12	11,2	8,0	22	4,75	8,20
R.7/32E	7/32	12	11,2	9,0	22	5,50	8,30
R.1/4E	1/4	12	11,2	10,1	22	6,00	9,30
R.9/32E	9/32	12	11,2	10,6	22	6,00	8,90
R.5/16E	5/16	12	12,0	12,0	22	6,50	11,50
R.11/32E	11/32	12	13,0	13,0	22	6,50	14,50
R.3/8E	3/8	12	14,7	14,7	22	7,80	17,80
R.13/32E	13/32	12	14,7	14,7	22	7,80	17,00
R.7/16E	7/16	12	15,8	15,8	22	9,00	19,5
R.1/2E	1/2	12	17,7	17,7	22	10,00	24,5
R.9/16E	9/16	12	18,7	18,7	22	10,00	25,20



▣ R.B - Nasadki 1/4" cienkościenne 12-kątne calowe

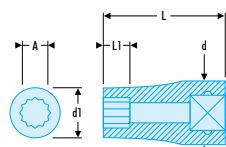

ASME B107-1

- Profil OGV®: większa siła i bezpieczeństwo, ochrona nakrętek.
- Pocienione ścianki zapewniające lepszy dostęp, zgodnie z normami lotniczymi.
- Wykończenie: chromowane błyszczące.

➤	A ["]	⊘ [mm]	d [mm]	d1 [mm]	L [mm]	L1 [mm]	ΔΔ [g]
RB.3/16	3/16	12	11,2	7,6	22	4,8	7,00
RB.7/32	7/32	12	11,2	8,7	22	5,5	8,00
RB.1/4	1/4	12	11,2	9,7	22	6,0	8,00
RB.9/32	9/32	12	11,2	10,6	22	6,0	10,50
RB.5/16	5/16	12	11,9	11,9	22	6,5	10,00
RB.11/32	11/32	12	12,9	12,9	22	6,5	11,50
RB.3/8	3/8	12	13,7	13,7	22	7,8	14,00
RB.7/16	7/16	12	14,8	15,8	22	9,0	17,00
RB.1/2	1/2	12	16,0	16,9	22	10,0	18,50
RB.9/16	9/16	12	17,5	18,7	22	10,0	22,00

Nasadki 1/4" długie

▣ R.LA - Nasadki 1/4" długie 6-kątne metryczne

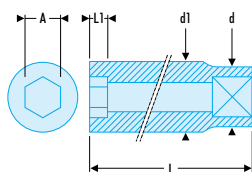

NF ISO 2725-1, NF ISO 1711-1, ISO 2725-1, ISO 1711-1, DIN 3124, ASME B107.5

- Profil OGV®: większa siła i bezpieczeństwo, ochrona nakrętek.
- Nasadki długie przeznaczone do gniazd lub długich gwintów.
- Dostępne w zestawie na stojaku metalowym: Symbol RL.40E (3,2 --> 9 mm) i symbol RL.41E (10 --> 14 mm).
- Wykończenie: chromowane błyszczące.

➤	A [mm]	⊘ [mm]	d [mm]	d1 [mm]	L [mm]	L1 [mm]	ΔΔ [g]
R.3,2LA	3,2	6	12,0	5,80	50,5	1,8	18
R.4LA	4,0	6	12,0	6,80	50,5	2,0	18
R.5LA	5,0	6	12,0	8,10	50,5	2,3	18
R.5,5LA	5,5	6	12,0	8,10	50,5	3,0	18
R.6LA	6,0	6	12,0	9,40	50,5	5,6	18
R.7LA	7,0	6	12,0	10,90	50,5	7,1	27
R.8LA	8,0	6	12,0	12,00	50,5	7,9	27
R.9LA	9,0	6	12,8	12,80	50,5	7,9	32
R.10LA	10,0	6	14,3	14,30	50,5	7,9	41
R.11LA	11,0	6	16,0	16,00	50,5	7,9	54
R.12LA	12,0	6	16,8	16,80	50,5	8,4	50
R.13LA	13,0	6	18,2	18,20	50,5	8,4	59
R.14LA	14,0	6	19,2	19,20	50,5	10,2	68

▣ R.RL - Nasadki 1/4" długie 12-kątne calowe

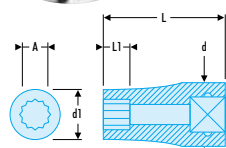

ASME B107.1

- Profil OGV®: większa siła i bezpieczeństwo, ochrona nakrętek.
- Nasadki długie przeznaczone do gniazd lub długich gwintów.
- Wysoki poziom skuteczności dostosowany do śrub stosowanych w aeronautyce.
- Pocienione ścianki zapewniające lepszy dostęp.
- Dostępne w zestawie na stojaku metalowym (symbol REL.40U).
- Wykończenie: chromowane błyszczące.

➤	A ["]	⊘ [mm]	d [mm]	d1 [mm]	L [mm]	L1 [mm]	ΔΔ [g]
R.3/16EL	3/16	12	10,9	7,7	50	6,0	14
R.7/32EL	7/32	12	10,9	8,5	50	7,4	15
R.1/4EL	1/4	12	10,9	9,4	50	7,4	17
R.9/32EL	9/32	12	10,9	10,2	50	8,5	17
R.5/16EL	5/16	12	11,8	11,4	50	9,0	23
R.11/32EL	11/32	12	12,0	12,5	50	9,7	25
R.3/8EL	3/8	12	12,8	13,7	50	11,2	32
R.7/16EL	7/16	12	14,3	15,6	50	11,9	40
R.1/2EL	1/2	12	16,2	17,3	50	13,8	45
R.9/16EL	9/16	12	17,1	18,8	50	16,2	49

R.F - Nasadki 1/4" przegubowe 12-kątnie calowe

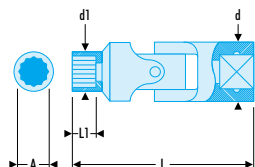

ASME B107.1

- Profil OGV®: większa siła i bezpieczeństwo, ochrona nakrętek.
- Kompaktowe rozwiązanie pozwalające na uniknięcie użycia przegubu.
- Wykończenie: chromowane błyszczące.

⇒	Ø [mm]	d [mm]	d1 [mm]	L [mm]	L1 [mm]	ΔΔ [g]
R.3/16F	12	13	8,0	31,6	5,3	13
R.7/32F	12	13	8,5	32,4	6,1	13
R.1/4F	12	13	9,8	32,8	6,5	13
R.9/32F	12	13	10,5	32,8	6,5	13
R.5/16F	12	13	12,0	33,3	7,0	14
R.11/32F	12	13	13,3	33,3	7,0	16
R.3/8F	12	13	13,7	34,6	8,3	21
R.7/16F	12	13	15,5	35,8	9,5	27
R.1/2F	12	13	18,0	36,8	10,5	34
R.9/16F	12	13	19,2	36,8	10,5	35

Nasadki 1/4" Torx®

RTX - Nasadki 1/4" Torx®

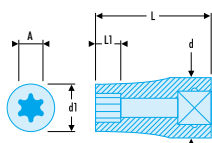

- Do śrub trzpieniowych Torx®.
- Wykończenie: chromowane błyszczące.
- Dostępne w zestawie na stojaku metalowym (symbol RTX.40).

⇒	A [mm]	Torx [Nr]	d [mm]	d1 [mm]	L [mm]	L1 [mm]	ΔΔ [g]
RTX.4	3,70	E4	11,2	5,4	22	3,2	8
RTX.5	4,58	E5	11,2	6,7	22	3,0	8
RTX.6	5,54	E6	11,2	7,7	22	3,6	8
RTX.7	6,22	E7	11,2	8,3	22	3,6	8
RTX.8	7,29	E8	11,2	9,6	22	4,3	9
RTX.10	9,19	E10	12,0	11,3	22	5,6	11

Nasadki wkrętakowe 1/4" z końcówkami wymiennymi

RT - Nasadki wkrętakowe 1/4" do śrub 6-kątnych metrycznych

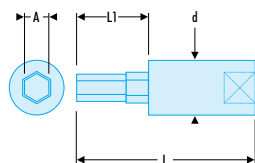

- Demontowalna końcówka o dużej twardości zapewniająca większą trwałość.
- Nasadka R.245.
- Wykończenie: chromowane błyszczące z końcówką fosforanową.

⇒	A [mm]	d [mm]	Końcówki	L [mm]	L1 [mm]	ΔΔ [g]
RT.2	2,0	11,3	EH.102	37	15	18
RT.2,5	2,5	11,3	EH.102,5	37	15	18
RT.3	3,0	11,3	EH.103	37	15	18
RT.4	4,0	11,3	EH.104	37	15	18
RT.5	5,0	11,3	EH.105	37	15	19
RT.6	6,0	11,3	EH.106	37	15	20
RT.7	7,0	11,3	EH.107	37	15	21
RT.8	8,0	11,3	EH.108	37	15	22
RT.10	10,0	11,3	EH.110	37	15	24



RT - Nasadki wkrętakowe 1/4" do śrub 6-kątnych calowych

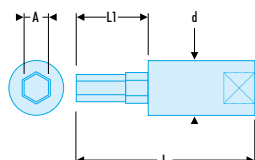

- Demontowalna końcówka o dużej twardości zapewniająca większą trwałość.
- Nasadka R.245.
- Wykończenie: chromowane błyszczące z końcówką fosforanowaną.

⇒	A [mm]	d [mm]	Kończówki	L [mm]	L1 [mm]	ΔΔ [g]
RT.1/8	3,17	11,3	EH.101/8	37	15	18
RT.5/32	3,96	11,3	EH.105/32	37	15	18
RT.3/16	4,76	11,3	EH.103/16	37	15	18
RT.7/32	5,56	11,3	EH.107/32	37	15	19
RT.1/4	6,35	11,3	EH.101/4	37	15	20

RX: nasadka wkrętakowa 1/4" do wkrętów Torx®

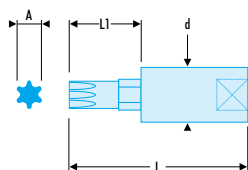

- Demontowalna końcówka o dużej twardości zapewniająca większą trwałość.
- Nasadka R.245.
- Wykończenie: chromowane błyszczące z końcówką fosforanowaną.

⇒	A [mm]	Torx [Nr]	d [mm]	Kończówki	L [mm]	L1 [mm]	ΔΔ [g]
RX.6	1,65	T6	11,3	EX.106	38	16	17
RX.7	1,97	T7	11,3	EX.107	38	16	17
RX.8	2,30	T8	11,3	EX.108	38	16	17
RX.9	2,48	T9	11,3	EX.109	38	16	17
RX.10	2,72	T10	11,3	EX.110	38	16	17
RX.15	3,26	T15	11,3	EX.115	38	16	17
RX.20	3,84	T20	11,3	EX.120	38	16	18
RX.25	4,40	T25	11,3	EX.125	38	16	18
RX.27	4,96	T27	11,3	EX.127	38	16	18
RX.30	5,49	T30	11,3	EX.130	38	16	18
RX.40	6,60	T40	11,3	EX.140	38	16	18

PRZYGOTUJ WŁASNY ZESTAW NASADEK - WKRETAKÓW

Kończówki do przykręcania



- Seria 1 \square 1/4"
- Seria 2 \square 5/16"

➔ **Patrz rozdział 7 str. 450**

Uchwyt końcówek \square 1/4"



R.235
 \square 1/4" 6,35 mm
pierścień osadczy
standardowy









































R.245
 \square 1/4" 6,35 mm
pierścień osadczy
wzmocniony

➔ **Patrz str. 458**



ZESTAWY 3/8" „DETECTION BOX”

WYMIARY METRYCZNE

		JL.DBOX1	JL.DBOX112	J.360DBOX1	J.360DBOX112	J.DBOX500	J.DBOX501
		JL.161	JL.161	J.360	J.360	J.171	J.171
		•	•	•	•	•	•
		•	•	•	•	•	•
		•	•	•	•	•	•
		•	•	•	•	•	•
		•	•	•	•	•	•
		•	•	•	•	•	•
		•	•	•	•	•	•
		•	•	•	•	•	•
		•	•	•	•	•	•
		•	•	•	•	•	•
		•	•	•	•	•	•
		•	•	•	•	•	•
		•	•	•	•	•	•
		•	•	•	•	•	•
		•	•	•	•	•	•
		•	•	•	•	•	•
		•	•	•	•	•	•
		•	•	•	•	•	•
		•	•	•	•	•	•
		•	•	•	•	•	•
		•	•	•	•	•	•
		•	•	•	•	•	•
		•	•	•	•	•	•
		•	•	•	•	•	•
		•	•	•	•	•	•
		•	•	•	•	•	•
		•	•	•	•	•	•
		•	•	•	•	•	•
		•	•	•	•	•	•
		•	•	•	•	•	•
		•	•	•	•	•	•
		•	•	•	•	•	•
		•	•	•	•	•	•
		•	•	•	•	•	•
		•	•	•	•	•	•
		•	•	•	•	•	•
		•	•	•	•	•	•

BV.J1NANO

50 x 124 x 280 mm

1,920 Kg | 1,920 Kg | 2,050 Kg | 2,050 Kg | 2,010 Kg | 2,010 Kg



JL.DBOX1



JL.DBOX112



J.360DBOX1



J.360DBOX112



J.DBOX500





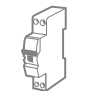
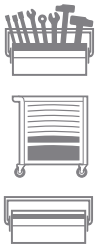



















J.DBOX501



ZESTAWY 3/8" KLASYCZNE

WYMIARY METRYCZNE

		J.420E	J.430AP	J.431AP	J.431ASP	J.430ASP
		J.151A	J.161	J.161	J.161	J.161
						
	mm					
	7	•	•	•	•	•
	8	•	•	•	•	•
	9	•	•	•	•	•
	10	•	•	•	•	•
	11	•	•	•	•	•
	12	•	•	•	•	•
	13	•	•	•	•	•
	14	•	•	•	•	•
	15	•	•	•	•	•
	16	•	•	•	•	•
	17	•	•	•	•	•
	18	•	•	•	•	•
	19	•	•	•	•	•
	20	•	•	•	•	•
	21	•	•	•	•	•
	22	•	•	•	•	•
	23	•	•	•	•	•
	24	•	•	•	•	•
	ED				•	•
	2				•	•
	3				•	•
	EH				•	•
	4				•	•
	5				•	•
	6				•	•
	mm				•	•
	8				•	•
	10				•	•
	ES				•	•
	6,5				•	•
	8				•	•
	10				•	•
	J.210		•	•	•	•
	J.215		•	•	•	•
	J.120A		•	•	•	•
	J.240A		•	•	•	•
	J.210RC					
	J.215RC					
	J.210S	•				
	J.235				•	•
	J.236C				•	•
	PL.19A		PL.412A		PL.411	
	BP.115		BP.112		BP.112	
	322 x 143 x 67 mm		389 x 164 x 66 mm		389 x 164 x 66 mm	
	1,50 Kg		1,96 Kg		2,75 Kg	

J.420E ▼



J.430AP ▼



J.431AP ▼



**J.430ASP ▼
J.431ASP ▼**



ZESTAWY NASADEK 3/8" KLASYCZNE

WYMIARY METRYCZNE

		J.451EP	J.426M	J.447E	JT.415E	JX.415EP
		J.161+J.156	-	J.151	J.151A	J.161
		Std	Końcówki	Std	Nasadki do wkrętek	Nasadki do wkrętek
		12	6	12	6	TORX®
		Długi		Klucz 39		
mm	7	•		•		
	8	•		•		
	9	•		•		
	10	•		•		
	11	•		•		
	12	•		•		
	13	•		•		
	14	•		•		
	15	•		•		
	16	•		•		
	17	•		•		
	18	•		•		
19	•		•			
21	•		•			
22	•		•			
24	•		•			
JT	3	•			•	
	4	•			•	
	5	•			•	
	6	•			•	
	7	•			•	
	8	•			•	
EP	1		•			
	2		•			
	3		•			
	4		•			
ED	1	•	•			
	2	•	•			
	3	•	•			
	4	•	•			
ES	4		•			
	5,5	•	•			
	6,5	•	•			
	8	•	•			
TORX®	10		•			•
	15		•			•
	20		•			•
	25		•			•
	27		•			•
	30		•			•
	40		•			•
	45		•			•
	50		•			•
	55		•			•
EH	3		•			
	4		•			
	5		•			
	6		•			
	7		•			
	8		•			
	10		•			
	J.210	•	•	•		
	J.120A	•				•
	J.240A	•				•
J.215R	•				•	
J.210S	•			•	•	
J.110	•				•	
J.235	•	•			•	
J.236	•	•			•	
J.216	•				•	
BJ.21A1			•			
BJ.16A1			•			
J.140A	•	•				
J.222		•				
		PL.77A BT.105	PL.20A BP.112	PL.27B BP.109	PL.20A BP.115	PL.118 BT.109G
		540 x 280 x 58 mm	389 x 164 x 66 mm	478 x 234 x 72 mm	322 x 143 x 66 mm	470 x 195 x 53 mm
		7,70 Kg	2,53 Kg	3,55 Kg	1,27 Kg	1,75 Kg

J.451EP



J.426M



J.447E









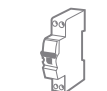



JT.415E



JX.415EP



ZESTAWY 3/8" W SKRZYŃCE PLASTIKOWEJ CALOWE

		J.430MU	JL.430MU	J.430UP	J.450U	J.420AU	
		J.161	JL.161	J.161	J.151A+J.156	J.161	
		Standard	Standard	Standard	Std Długie	Standard	
 mm	7	•	•				
	8	•	•				
	9	•	•				
	10	•	•				
	11	•	•				
	12	•	•				
	13	•	•				
	14	•	•				
	15	•	•				
	16	•	•				
	17	•	•				
	18	•	•				
	19	•	•				
	20	•	•				
	21	•	•				
	22	•	•				
24	•	•					
 "	1/4	•	•	•	•	•	
	5/16	•	•	•	•	•	
	3/8	•	•	•	•	•	
	7/16	•	•	•	•	•	
	1/2	•	•	•	•	•	
	9/16	•	•	•	•	•	
	5/8	•	•	•	•	•	
	11/16	•	•	•	•	•	
	3/4	•	•	•	•	•	
	13/16	•	•	•	•	•	
	7/8	•	•	•	•	•	
	15/16	•	•	•	•	•	
	1	•	•	•	•	•	
	 JT	1/8				•	
		5/32				•	
3/16					•		
7/32					•		
1/4					•		
5/16					•		
 mm	3/8				•		
	ED				•		
	2				•		
	3				•		
 ES	5,5				•		
	6,5				•		
	8				•		
	10				•		
	J.210	•	•	•	•	•	
	J.215	•	•	•	•	•	
	J.120A	•	•	•	•	•	
	J.240A	•	•	•	•	•	
	J.110			•	•	•	
	J.235				•	•	
	J.236				•	•	
	J.216				•	•	
	J.140A				•	•	
	PL.59A	PL.59A	PL.12A	PL.78A	PL.69A		
	BP.109	BP.109	BP.109	BT.105	BP.115		
	478 x 234 x 72 mm	478 x 234 x 72 mm	478 x 234 x 72 mm	540 x 80 x 58 mm	332 x 143 x 67 mm		
	4,18 Kg	4,110 Kg	3,73 Kg	7,38 Kg	2,70 Kg		

J.430MU



JL.430MU



J.430UP



J.450U



J.420AU























ZESTAWY NASADEK 3/8"

NA STOJAKACH LUB W SKRZYŃKACH

		J.40E	JL.40E	JL.41E	J.40U	JL.40U	JTX.40	JT.40
		Standard	Długie	Długie	Standard	Długie	TORX Standard	NASADKI DO WKRETAKÓW TORX Standard
	mm	7	•	•				
	8	•	•					
	9	•	•					
	10	•	•					
	11	•	•					
	12	•	•					
	13	•	•					
	14	•	•					
	15	•	•					
	16	•	•					
	17			•				
	18			•				
	19			•				
	21			•				
	22			•				
	24			•				
	"	1/4			•	•		
	5/16				•	•		
	3/8				•	•		
	7/16				•	•		
	1/2				•	•		
	9/16				•	•		
	5/8				•	•		
	11/16				•	•		
	3/4							
	13/16							
Nasadki TORX®	E4						•	
	E5						•	
	E6						•	
	E7						•	
	E8						•	
	E10						•	
	mm	8						•
	10							•
	12							•
	14							•
	16							•
		CKS.94				CKS.91		
		0,380 Kg	0,590 Kg	0,870 Kg	0,340 Kg	0,840 Kg	0,090 Kg	0,280 Kg



MODUŁY 3/8" WKŁADKI TERMOFORMOWANE

		MOD.JL1	MOD.J1	MOD.J5	MOD.J7	MOD.J2
		JL.161	J.161	J.171	J.161+J.174	J.161
		•	•	•	•	•
mm	7	•	•	•	•	•
	8	•	•	•	•	•
	9	•	•	•	•	•
	10	•	•	•	•	•
	11	•	•	•	•	•
	12	•	•	•	•	•
	13	•	•	•	•	•
	14	•	•	•	•	•
	15	•	•	•	•	•
	16	•	•	•	•	•
	17	•	•	•	•	•
	18	•	•	•	•	•
	19	•	•	•	•	•
	20					
	21	•	•	•	•	•
	22	•	•	•	•	•
	23					•
	24					•
						•
"	1/4					•
	5/16					•
	3/8					•
	7/16					•
	1/2					•
	9/16					•
	5/8					•
	11/16					•
	3/4					•
	13/16					•
	7/8					•
	15/16					•
	1					
						
JT	1/8					
	5/32					
	3/16					
	7/32					
	1/4					
	5/16					
	3/8					
						
EP	1					
	2					
	3					
	4					
						
ES	5,5					
	6,5					
	8					
	10					
		•	•			•
	J.210	•	•			•
		•	•			•
	J.215	•	•			•
		•	•	•	•	•
	J.120A	•	•	•	•	•
		•	•	•	•	•
	J.240A	•	•	•	•	•
				•	•	
	J.210RC			•	•	
				•	•	
	J.215RC			•	•	
						
	J.210S					
						
	J.110					
		•				
	J.235	•				
		•				
	J.232	•				
						
	J.216					
						
	J.140A					
		PL.686	PL.322A	PL.322A	PL.665	PL.601
		435 x 198 x 55 mm		420 x 180 x 55 mm		
		2,25 Kg	1,80 Kg	1,75 Kg	2,20 Kg	1,52 Kg

MOD.JL1



MOD.J1



MOD.J5









MOD.J7



MOD.J2

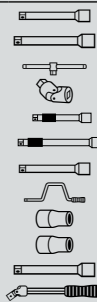

MODUŁY 3/8" WKŁADKI PIANKOWE

		MODM.JL1
		JL.161
	J.8H	•
	J.9H	•
	J.10H	•
	J.11H	•
	J.12H	•
	J.13H	•
	J.14H	•
	J.15H	•
	J.16H	•
	J.17H	•
	J.18H	•
	J.19H	•
	J.21H	•
	J.22H	•
	J.210	•
	J.215	•
	J.120A	•
	J.240A	•
	J.210RC	
	J.215RC	
	J.210S	
	J.110	
	J.235	•
	J.232	•
	J.216	
J.140A		
		PM.MODJL1
		416 x 190 x 50 mm
		1,88 Kg

MODM.JL1



Grzechotki 3/8"

■ Grzechotka 3/8" szczelna o wysokich parametrach

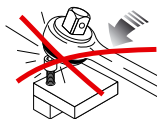
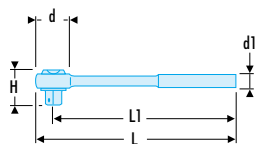

NF ISO 3315, ISO 3315, DIN 3122, ASME B107.10

- Bardzo wysoka trwałość bez konserwacji, niezależnie od warunków pracy.
- Szczelność na pyły, szlasy przemysłowe itp.
- Mechanizm z 72 zębami i skokiem co 5°.
- Odwracanie kierunku za pomocą dźwigni umożliwiającej wzrokową kontrolę kierunku obrotów.
- System „na docisk dłonią”, umożliwiający dociskanie główki grzechotki podczas dokręcania i odkręcania bez ryzyka przypadkowego odwrócenia kierunku obrotów.
- Główna ultra-kompaktowa.
- Oczko do zaczepiania do prac na wysokości.
- Wyjątkowa wygoda.

⇒	d [mm]	d1 [mm]	H [mm]	L [mm]	L1 [mm]	ΔΔ [g]
JL.161	29	27	29	210	195	200

■ Grzechotka 3/8" szybka z rękojeścią obrotową

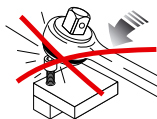
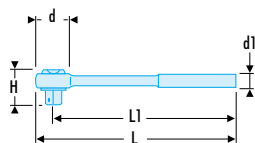

NF ISO 3315, ISO 3315, DIN 3122, ASME B107.10

- Szybka grzechotka 3/8" z obrotowym uchwytem
- Mechanizm z pokrętkiem: działa dwukrotnie szybciej, nawet w niedostępnych miejscach.
- Skok zęba grzechotki 6° przy użytkowaniu.
- Blokada bezpieczeństwa
- Funkcja grzechotki "na docisk dłonią"
- Okrągła główka grzechotki: przełączenie poprzez pierścien

⇒	d [mm]	d1 [mm]	H [mm]	L [mm]	L1 [mm]	ΔΔ [g]
J.360	37	37	39	233	233	442

■ Grzechotka 3/8" „na docisk dłonią”.

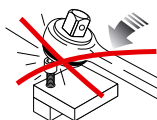
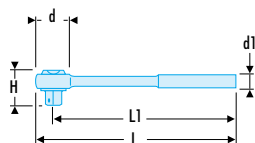

NF ISO 3315, ISO 3315, DIN 3122, ASME B107.10

- Mechanizm z 72 zębami o skoku 5°.
- System „na docisk dłonią”, umożliwiający dociskanie główki grzechotki podczas dokręcania i odkręcania bez ryzyka przypadkowego odwrócenia kierunku obrotów.
- Odwracanie kierunku za pomocą pierścienia.

⇒	d [mm]	d1 [mm]	H [mm]	L [mm]	L1 [mm]	ΔΔ [g]
J.161	30	25	32	175	164	210

Grzechotka 3/8" klasyczna

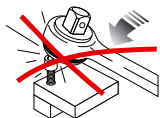
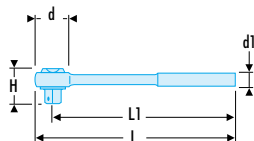

NF ISO 3315, ISO 3315, DIN 3122, ASME B107.10

- Mechanizm z 72 zębami o skoku 5°.
- Odwracanie kierunku za pomocą pierścienia obrotowego.

🔧	d [mm]	d1 [mm]	H [mm]	L [mm]	L1 [mm]	ΔΔ [g]
J.151A	30	21	29	179	179	200

Grzechotka 3/8" z blokadą

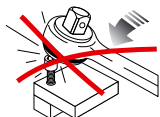
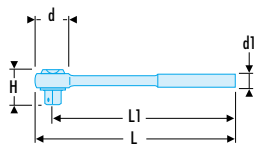

NF ISO 3315, ISO 3315, DIN 3122, ASME B107.10

- Mechanizm z 72 zębami o skoku 5°.
- System „na docisk dłonią”, umożliwiający dociskanie główki grzechotki podczas dokręcania i odkręcania bez ryzyka przypadkowego odwrócenia kierunku obrotów.
- Odwracanie kierunku za pomocą pierścienia.
- Blokada bezpieczeństwa nasadki = zapobiega zagubieniu nasadki w maszynach.
- Długa rękojeść zmniejszająca zmęczenie.

🔧	d [mm]	d1 [mm]	H [mm]	L [mm]	L1 [mm]	ΔΔ [g]
J.171	32,5	28	36	210	195	260

Grzechotka 3/8" długa z blokadą

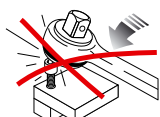
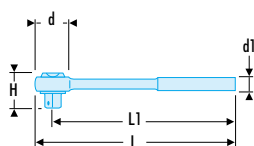

NF ISO 3315, ISO 3315, DIN 3122, ASME B107.10

- Mechanizm z 72 zębami o skoku 5°.
- System „na docisk dłonią”, umożliwiający dociskanie główki grzechotki podczas dokręcania i odkręcania bez ryzyka przypadkowego odwrócenia kierunku obrotów.
- Odwracanie kierunku za pomocą pierścienia.
- Blokada bezpieczeństwa nasadki = zapobiega zagubieniu nasadki w maszynach.
- Długa rękojeść zmniejszająca zmęczenie.

🔧	d [mm]	d1 [mm]	H [mm]	L [mm]	L1 [mm]	ΔΔ [g]
J.174	32,5	28	36	250	234	320

Grzechotka 3/8" długa z główką przegubową

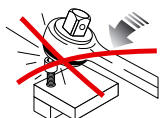
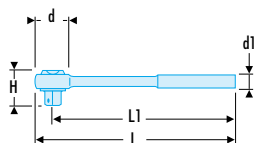

NF ISO 3315, ISO 3315, DIN 3122, ASME B107.10

- Mechanizm z 72 zębami o skoku 5°.
- System „na docisk dłonią”, umożliwiający dociskanie główki grzechotki podczas dokręcania i odkręcania bez ryzyka przypadkowego odwrócenia kierunku obrotów.
- Odwracanie kierunku za pomocą pierścienia.
- Rękojeść ekstra-długa do przykładania wyższego momentu bez zmęczenia.
- Przegub hamowany umożliwiający zachowanie położenia nawet z założonym przedłużaczem i nasadką.

🔧	d [mm]	d1 [mm]	H [mm]	L [mm]	L1 [mm]	ΔΔ [g]
J.153A	30	25	32	278	263	315

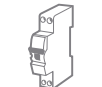

Grzechotka 3/8" z główką przegubową i rękojeścią metalową

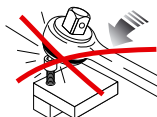
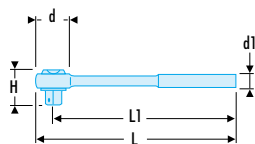



NF ISO 3315, ISO 3315, DIN 3122, ASME B107.10

- Mechanizm z 72 zębami o skoku 5°.
- System „na docisk dłonią”, umożliwiający dociskanie główki grzechotki podczas dokręcania i odkręcania bez ryzyka przypadkowego odwrócenia kierunku obrotów.
- Przegub hamowany umożliwiający zachowanie położenia nawet z założonym przedłużaczem i nasadką.
- Całkowicie metalowa rękojeść, radełkowana na uchwycie.

☞	d [mm]	d1 [mm]	H [mm]	L [mm]	L1 [mm]	ΔΔ [g]
J.158A	30	16	32	273	258	350

KONSERWACJA GRZECHOTEK 1/2"

☞	J.171	J.161	J.151A	J.174	J.153A	J.161E	J.155A	J.157A	J.158A	J.159A	J.156
Nakładki											
 J.161C		•				•	•	•	•	•	
S.156C											•
J.151AC			•								
Zestaw części zamiennych											
 J.161RN		•				•	•	•	•	•	
S.151RN											•
J.151RN			•								
Zabierak											
 J.151AR		•	•		•	•	•	•	•	•	
J.151R											•

Akcesoria 3/8"

Rękojeść przegubowa 3/8"

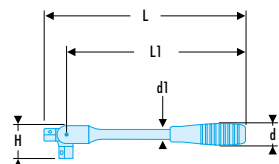

NF ISO 3315, ISO 3315, DIN 3122, ASME B107.10

- Przegub z hamowaniem.
- Wykończenie: chromowane błyszczące.

☞	d [mm]	d1 [mm]	H [mm]	L [mm]	L1 [mm]	ΔΔ [g]
J.140A	25	10	33,5	260	235,5	230

Rękojeść przegubowa 3/8" z uchwytem metalowym

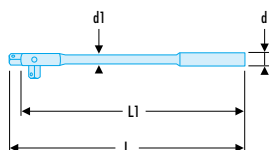

NF ISO 3315, ISO 3315, DIN 3122, ASME B107.10

- Przegub z hamowaniem.
- Wykończenie: chromowane błyszczące.

☞	d [mm]	d1 [mm]	L [mm]	L1 [mm]	ΔΔ [g]
J.145	17	11	255	245	290

▣ Rękojeść przesuwna 3/8"

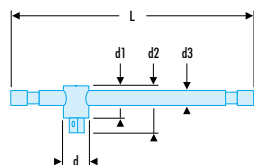

NF ISO 3315, ISO 3315, DIN 3122, ASME B107.10

- Hamulec umieszczony na główce rękojeści podtrzymuje położenie trzpienia przesuwającego, który dzięki temu może tworzyć klucz w kształcie T lub L.
- Wykończenie: chromowane błyszczące.

🔧	d [mm]	d1 [mm]	d2 [mm]	d3 [mm]	L [mm]	ΔΔ [g]
J.120A	20	23	34	12	200	215



▣ Korba 3/8"

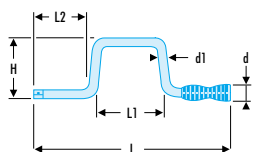

NF ISO 3315, ISO 3315, DIN 3122, ASME B107.10

- Duża szybkość manewrowania.
- Rękojeść obrotowa PCV.
- Wykończenie: chromowane błyszczące.

🔧	d [mm]	d1 [mm]	H [mm]	L [mm]	L1 [mm]	L2 [mm]	ΔΔ [g]
J.110A	29	12	115	382	130	110	395



▣ Korba 3/8" z uchwytem metalowym

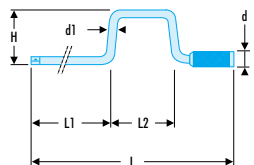

NF ISO 3315, ISO 3315, DIN 3122, ASME B107.10

- Duża szybkość manewrowania.
- Rękojeść obrotowa metalowa.
- Wykończenie: chromowane błyszczące.

🔧	d [mm]	d1 [mm]	H [mm]	L [mm]	L1 [mm]	L2 [mm]	ΔΔ [g]
J.115	29	9,5	75	420	195	125	425



▣ **J.222A** Rękojeść wkrętakowa 3/8" giętka



- Ergonomiczna rękojeść z dwóch materiałów.
 - Idealna do miejsc trudno dostępnych dzięki giętkiemu grotowi.
 - Długość: 295 mm.
 - Wykończenie: chromowane satynowane.
- Masa: 230 g.



▣ Rękojeść z przegubem kardana 3/8"

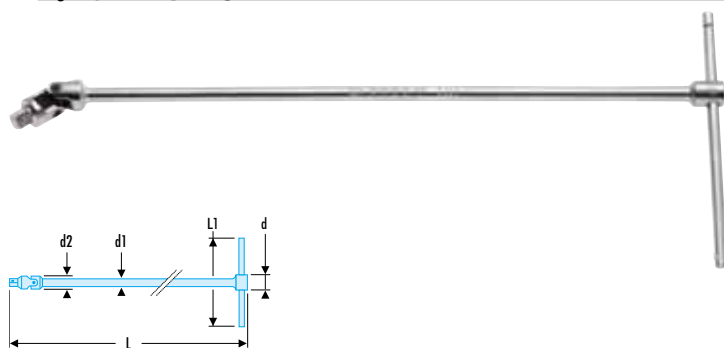

- Przegub przenosi wysokie momenty dokręcania i zapewnia utrzymanie nasadki w stałym położeniu (hamowanie za pomocą sprężyny).
- Dzięki swojej długości i kątowi wychylenia do 65°, klucz ten może być używany do nakrętek w trudno dostępnych miejscach.
- Rękojeść w kształcie T, przesuwna, umożliwia ustawienie w położeniu T lub L dla większej siły.
- Wykończenie: chromowane błyszczące.

☞	d [mm]	d1 [mm]	d2 [mm]	L [mm]	L1 [mm]	ΔΔ [g]
J.229A	17	10	19	460	175	410

▣ Rękojeść z przegubem kardana 3/8" długa

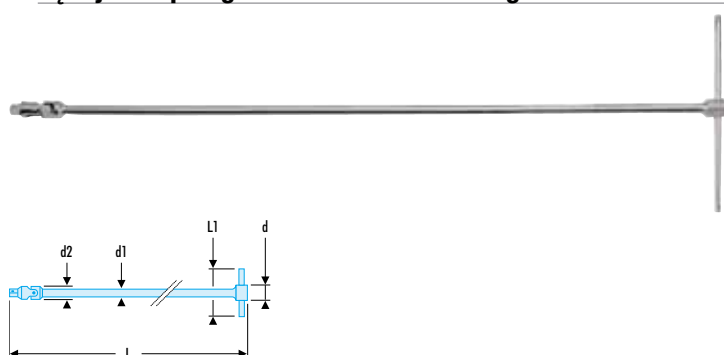

- Przegub przenosi wysokie momenty dokręcania i zapewnia utrzymanie nasadki w stałym położeniu (hamowanie za pomocą sprężyny).
- Dzięki swojej długości i kątowi wychylenia do 65°, klucz ten może być używany do nakrętek w trudno dostępnych miejscach.
- Rękojeść w kształcie T, przesuwna, umożliwia ustawienie w położeniu T lub L dla większej siły.
- Wykończenie: chromowane błyszczące.

☞	d [mm]	d1 [mm]	d2 [mm]	L [mm]	L1 [mm]	ΔΔ [g]
J.228	18	12	19	700	190	660

▣ J - Przedłużacze 3/8"

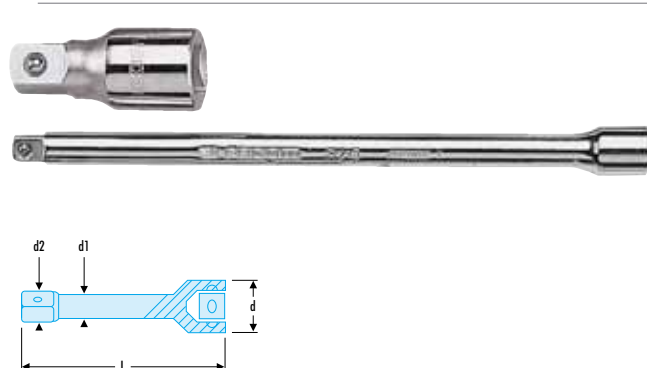

NF ISO 3316, ISO 3316, DIN 3123, ASME B107.10

- Wykończenie: chromowane błyszczące.

☞	d [mm]	d1 [mm]	d2 [mm]	L [mm]	ΔΔ [g]
J.208	18	10	12,6	50	62
J.209	18	10	12,6	75	86
J.210	18	10	12,6	125	127
J.215	18	10	12,6	250	230
J.217	18	10	12,6	500	445

▣ J.S - Przedłużacze kątowe 3/8"

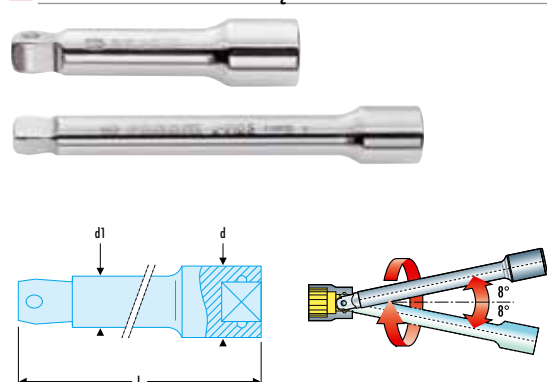

Kształt zabieraka pozwala na odchylenie przedłużacza o 8° w stosunku do nasadki.

Pomyśl o przedłużaczu kątowym!

- Wykończenie: chromowane błyszczące.

☞	d [mm]	d1 [mm]	L [mm]	ΔΔ [g]
J.209S	18	12,5	75	80
J.210S	18	12,5	125	130

PRZEDŁUŻACZE KĄTOWE

**Element niedostępny za pomocą nasadki lub przegubu?
POMYŚL O PRZEDŁUŻACZU KĄTOWYM!**

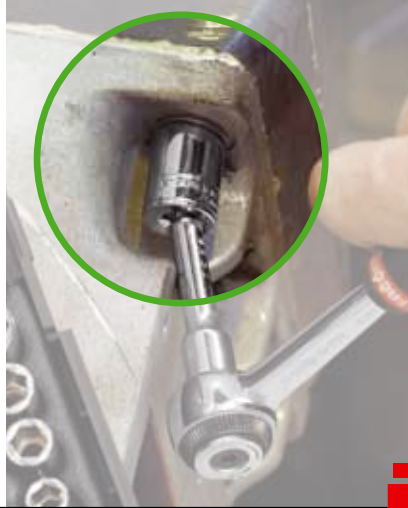
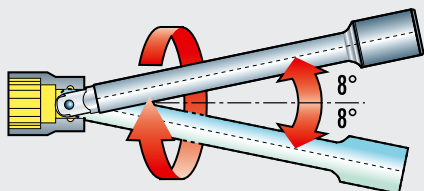

J.RC - Przedłużacz 3/8" z blokadą

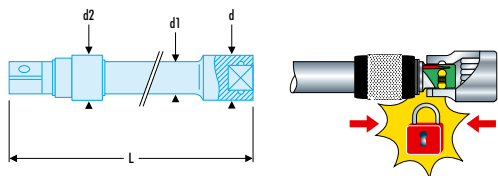

NF ISO 3316, ISO 3316, DIN 3123, ASME B107.10

- Całkowite bezpieczeństwo: mechanizm blokujący zapobiega przypadkowemu wypadnięciu nasadki.
- Wykończenie: chromowane błyszczące z pierścieniem blokującym fosforanowanym.

Symbol	d [mm]	d1 [mm]	d2 [mm]	L [mm]	ΔΔ [g]
J.210RC	18	12,5	18	125	135
J.215RC	18	12,5	18	250	240
J.217RC	18	12,5	18	500	490

Przedłużacz giętki 3/8"

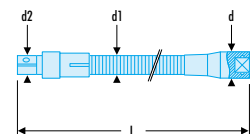

ASME B107.10

- Maksymalna dostępność.
- Nie może być używana do mocnego dokręcania:
- Wykończenie: chromowane błyszczące.

Symbol	d [mm]	d1 [mm]	d2 [mm]	L [mm]	ΔΔ [g]
J.216	18	12,6	15	200	145

Przegub uniwersalny 3/8"

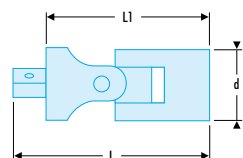

NF ISO 3316, ISO 3316, DIN 3123, ASME B107.10

- Przegub hamowany sprężyną.
- Wykończenie: chromowane błyszczące.

Symbol	d [mm]	L [mm]	L1 [mm]	ΔΔ [g]
J.240A	18	51,5	36,5	60



Reduktor z 3/8" do 1/4"

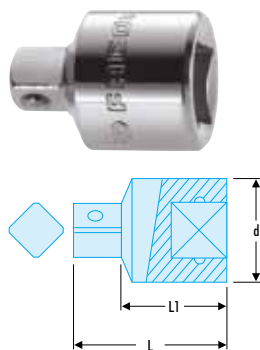

NF ISO 3316, ISO 3316, DIN 3123, ASME B107.10

- Do stosowania z nasadkami 1/4".
- Moment maksymalny: 62 N.m.
- Wykończenie: chromowane błyszczące.

☞	d [mm]	L [mm]	L1 [mm]	ΔΔ [g]
J.230	17,5	24,5	17	25

Przełożenie 3/8" do 1/2"

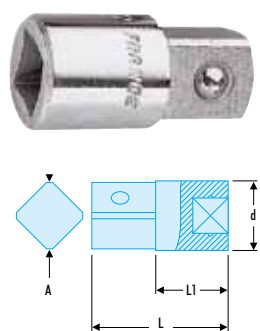

NF ISO 3316, ISO 3316, DIN 3123, ASME B107.10

- Do stosowania z nasadkami 1/2".
- Wykończenie: chromowane błyszczące.

☞	A [mm]	d [mm]	L [mm]	L1 [mm]	ΔΔ [g]
J.232	16,5	18	34,5	19	45

D.169 Zestaw 3 adaptorów



- Rozpórki umożliwiają używanie narzędzi z zabierakiem o wymiarach mniejszych od nasadki:
 - Zabierak 1/4 + D.169RJ --> nasadka 3/8.
 - Zabierak 3/8 + D.169JS --> nasadka 1/2.
 - Zabierak 1/2 --> nasadka 3/4.
 - Małe wymiary zewnętrzne pozwalające zredukować ilość narzędzi potrzebnych przy interwencjach serwisowych.
 - Mocowanie magnetyczne i blokada (JS i SK).
 - Pierścień ryflowany umożliwiający dotarcie do miejsc trudno dostępnych.
- Masa: 96 g.

J - Nasadki 3/8" z pierścieniem sprężynującym

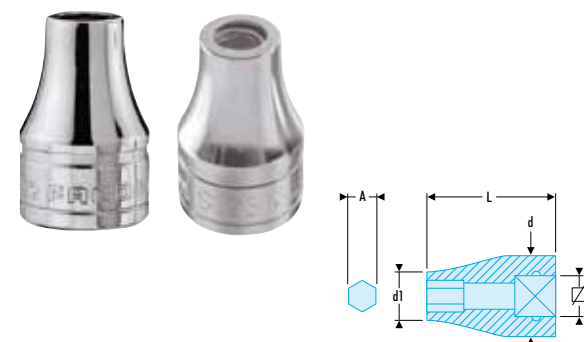

NF ISO 2725-1, NF ISO 1173, ISO 2725-1, ISO 1173, DIN 3124

- Z zatrzaskiem blokującym do końcówek do dokręcania.
- Do częstego demontażu.
- Wykończenie: chromowane błyszczące.
- J.235: końcówki 1/4.
- J.236: końcówki 5/16.

☞	A ["]	Kwadrat ["]	d [mm]	d1 [mm]	L [mm]	ΔΔ [g]
J.235	1/4	3/8	18,0	11,3	30	26
J.236	5/16	3/8	18,0	14	30	30

Nasadka uchwyt do końcówek z pierścieniem blokującym 3/8" do końcówek 1/4"



NF ISO 2725-1, NF ISO 1173, ISO 2725-1, ISO 1173, DIN 3124

- Blokowanie końcówki.
- Końcówka kwadratowa wyposażona w otwór na zatrzask kulkowy lub zaczepek.

EF	A ["]	Kwadrat ["]	L [mm]	ΔΔ [g]
EF.J	1/4	3/8	43	48

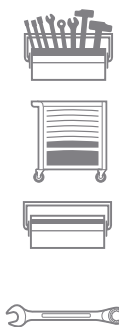

Nasadki 3/8"

J.H - Nasadki 3/8" 6-kątne metryczne

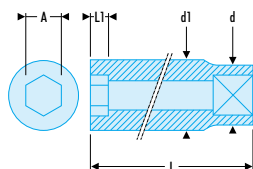

NF ISO 2725-1, NF ISO 1711-1, ISO 2725-1, ISO 1711-1, DIN 3124, ASME B107.5

- Profil OGV®: większa siła i bezpieczeństwo, ochrona nakrętek.
- Dostępne w zestawie na stojaku metalowym (symbol J.40U).
- Wykończenie: chromowane błyszczące.

EF	A [mm]	Ø [mm]	d [mm]	d1 [mm]	L [mm]	L1 [mm]	ΔΔ [g]
J.7H	7	6	17,6	11,0	27	6,0	24
J.8H	8	6	17,6	12,2	27	6,5	25
J.9H	9	6	17,6	13,5	27	6,7	25
J.10H	10	6	17,6	14,7	27	7,8	26
J.11H	11	6	17,6	16,0	27	9,0	27
J.12H	12	6	17,6	17,2	27	9,5	26
J.13H	13	6	17,4	18,3	30	10,4	36
J.14H	14	6	17,6	19,5	30	10,5	34
J.15H	15	6	18,9	20,8	30	12,0	38
J.16H	16	6	19,9	22,0	30	12,0	45
J.17H	17	6	21,7	23,4	30	13,0	52
J.18H	18	6	21,7	24,7	33	13,0	69
J.19H	19	6	22,7	26,0	33	14,0	62
J.20H	20	6	22,2	27,2	33	15,0	70
J.21H	21	6	23,5	28,5	33	16,0	75
J.22H	22	6	24,7	29,7	33	16,5	80
J.23H	23	6	26,0	31,0	33	16,5	90
J.24H	24	6	26,3	31,3	33	16,5	86

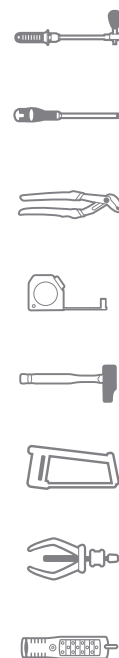

J - Nasadki 3/8" 12-kątne metryczne

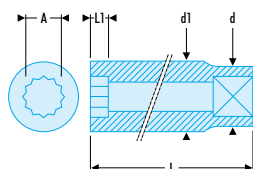

NF ISO 2725-1, NF ISO 1711-1, ISO 2725-1, ISO 1711-1, DIN 3124, ASME B107.5

- Profil OGV®: większa siła i bezpieczeństwo, ochrona nakrętek.
- Wykończenie: chromowane błyszczące.

EF	A [mm]	Ø [mm]	d [mm]	d1 [mm]	L [mm]	L1 [mm]	ΔΔ [g]
J.7	7	12	17,6	11,0	27	6,0	24
J.8	8	12	17,6	12,2	27	6,5	25
J.9	9	12	17,6	13,5	27	6,7	25
J.10	10	12	17,6	14,7	27	7,8	26
J.11	11	12	17,6	16,0	27	9,0	27
J.12	12	12	17,6	17,2	27	9,5	26
J.13	13	12	17,5	18,3	30	10,4	36
J.14	14	12	17,7	19,5	30	10,5	34
J.15	15	12	19,0	20,8	30	12,0	38
J.16	16	12	20,0	22,0	30	12,0	45
J.17	17	12	21,7	23,4	30	13,0	52
J.18	18	12	21,7	24,7	33	13,0	69
J.19	19	12	22,7	26,0	33	14,0	62
J.20	20	12	22,2	27,2	33	15,0	70
J.21	21	12	23,5	28,5	33	16,0	75
J.22	22	12	24,7	29,7	33	16,5	80
J.23	23	12	26,0	31,0	33	16,5	90
J.24	24	12	26,3	31,3	33	16,5	86

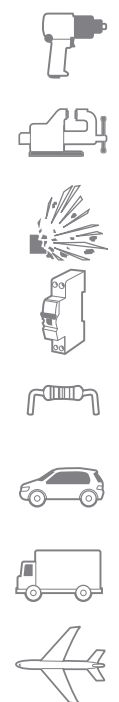

■ J - Nasadki 3/8" 12-kątne calowe

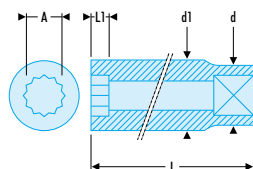

ASME B107.1

- Profil OGV®: większa siła i bezpieczeństwo, ochrona nakrętek.
- Dostępne w zestawie na stojaku metalowym (symbol J.40U).
- Wykończenie: chromowane błyszczące.

➤	A ["]	⊘ [mm]	d [mm]	d1 [mm]	L [mm]	L1 [mm]	ΔΔ [g]
J.1/4	1/4	12	17,5	10,0	27	6,0	24
J.5/16	5/16	12	17,5	11,9	27	6,5	25
J.3/8	3/8	12	17,6	14,1	27	7,5	26
J.7/16	7/16	12	17,5	16,0	27	9,0	27
J.1/2	1/2	12	17,5	18,1	30	10,4	36
J.9/16	9/16	12	17,7	19,5	30	10,5	34
J.5/8	5/8	12	20,0	22,0	30	12,0	46
J.11/16	11/16	12	21,0	24,0	33	13,0	74
J.3/4	3/4	12	22,7	26,0	33	14,0	76
J.13/16	13/16	12	23,0	28,0	33	16,0	79
J.7/8	7/8	12	24,7	29,7	33	16,5	104
J.15/16	15/16	12	26,3	31,3	33	16,5	136
J.1"	1	12	28,3	33,3	33	16,5	156

■ JB - Nasadki 3/8" 12-kątne calowe cienkościenne

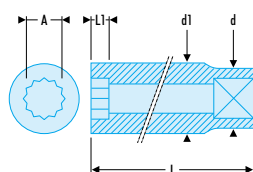

ASME B107.1

- Profil OGV®: większa siła i bezpieczeństwo, ochrona nakrętek.
- Zgodne z normami lotniczymi.
- Wykończenie: chromowane błyszczące.

➤	A ["]	⊘ [mm]	d [mm]	d1 [mm]	L [mm]	L1 [mm]	ΔΔ [g]
JB.1/4	1/4	12	16,7	9,7	27	6,0	20
JB.5/16	5/16	12	16,7	11,7	27	6,8	21
JB.11/32	11/32	12	16,7	12,7	27	6,8	22
JB.3/8	3/8	12	16,7	13,7	27	7,5	23
JB.7/16	7/16	12	16,7	15,6	27	9,0	24
JB.1/2	1/2	12	16,7	17,6	30	10,4	27
JB.9/16	9/16	12	18,5	19,6	30	10,5	33
JB.5/8	5/8	12	20,0	21,6	30	12,0	42
JB.11/16	11/16	12	22,0	23,6	32	13,0	50
JB.3/4	3/4	12	22,8	25,4	32	15,0	55
JB.13/16	13/16	12	24,0	27,4	32	16,0	68
JB.7/8	7/8	12	24,0	29,4	32	16,0	68

■ J.HLA - Nasadki 3/8" długie 6-kątne metryczne

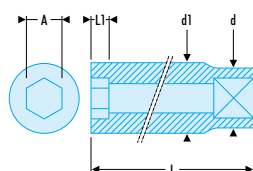

NF ISO 2725-1, NF ISO 1711-1, ISO 2725-1, ISO 1711-1, DIN 3124, ASME B107.5

- Profil OGV®: większa siła i bezpieczeństwo, ochrona nakrętek.
- Nasadki długie przeznaczone do gniazd lub długich gwintów.
- Dostępne w zestawie na stojaku metalowym: Symbol JL.40E (7 --> 15 mm) i symbol JL.41E (16 --> 24 mm).
- Wykończenie: chromowane błyszczące.

➤	A [mm]	⊘ [mm]	d [mm]	d1 [mm]	L [mm]	L1 [mm]	ΔΔ [g]
J.7HLA	7	6	17,3	10,6	55	6,0	44
J.8HLA	8	6	17,3	12,0	55	7,5	46
J.9HLA	9	6	17,3	13,0	55	7,5	47
J.10HLA	10	6	17,3	14,5	55	9,0	50
J.11HLA	11	6	17,3	16,0	55	10,5	53
J.12HLA	12	6	17,2	16,8	55	12,0	53
J.13HLA	13	6	17,0	18,0	55	12,0	54
J.14HLA	14	6	18,0	20,0	55	15,0	60
J.15HLA	15	6	20,0	21,0	60	15,0	75
J.16HLA	16	6	20,0	22,0	60	15,0	85
J.17HLA	17	6	22,0	23,5	60	15,0	102
J.18HLA	18	6	23,0	24,5	60	18,0	109
J.19HLA	19	6	24,0	25,0	60	18,0	110
J.21HLA	21	6	26,0	27,0	60	18,0	123
J.22HLA	22	6	28,0	29,0	60	21,0	150
J.24HLA	24	6	30,0	31,0	60	24,0	176

J.LA - Nasadki 3/8" długie 12-kątne metryczne

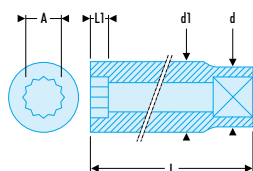

NF ISO 2725-1, NF ISO 1711-1, ISO 2725-1, ISO 1711-1, DIN 3124, ASME B107.5

- Profil OGV®: większa siła i bezpieczeństwo, ochrona nakrętek.
- Nasadki długie przeznaczone do gniazd lub długich gwintów.
- Dostępne w zestawie na stojaku metalowym (symbol J.L40U).
- Wykończenie: chromowane błyszczące.

⇒	A [mm]	⚙ [mm]	d [mm]	d1 [mm]	L [mm]	L1 [mm]	ΔΔ [g]
J.7LA	7	12	17,3	10,6	55	6,0	44
J.8LA	8	12	17,3	12,0	55	7,5	46
J.9LA	9	12	17,3	13,0	55	7,5	47
J.10LA	10	12	17,3	14,5	55	9,0	50
J.11LA	11	12	17,3	16,0	55	10,5	53
J.12LA	12	12	17,3	16,8	55	12,0	53
J.13LA	13	12	17,2	18,0	55	12,0	54
J.14LA	14	12	17	20,0	55	15,0	60
J.15LA	15	12	18	21,0	55	15,0	75
J.16LA	16	12	20	22,0	60	15,0	85
J.17LA	17	12	20	23,5	60	15,0	102
J.18LA	18	12	22	24,5	60	18,0	109
J.19LA	19	12	23	25,0	60	18,0	110
J.21LA	21	12	24	27,0	60	18,0	123
J.22LA	22	12	26	29,0	60	21,0	150
J.24LA	24	12	30	31,0	60	21,0	176

J.LA - Nasadki 3/8" długie 12-kątne calowe

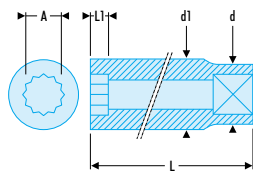

ASME B107.1

- Profil OGV®: większa siła i bezpieczeństwo, ochrona nakrętek.
- Nasadki długie przeznaczone do gniazd lub długich gwintów.
- Wykończenie: chromowane błyszczące.

⇒	A ["]	⚙ [mm]	d [mm]	d1 [mm]	L [mm]	L1 [mm]	ΔΔ [g]
J.1/4LA	1/4	12	17,5	10,6	44,7	4,0	36
J.5/16LA	5/16	12	17,5	12,4	44,7	4,3	36
J.3/8LA	3/8	12	17,5	14,3	44,7	4,7	41
J.7/16LA	7/16	12	17,5	16,2	44,7	6,2	45
J.1/2LA	1/2	12	18,2	18,2	44,7	7,4	50
J.9/16LA	9/16	12	20,5	20,5	48,0	9,0	72
J.5/8LA	5/8	12	22,3	22,3	63,8	10,2	104
J.11/16LA	11/16	12	23,8	23,8	63,8	10,2	113
J.3/4LA	3/4	12	25,3	25,3	63,8	11,8	127
J.13/16LA	13/16	12	27,0	27,0	63,8	12,3	140
J.7/8LA	7/8	12	30,2	30,2	63,8	12,7	181
J.15/16LA	15/16	12	31,8	31,8	63,8	12,7	185
J.1"LA	1	12	33,4	33,4	63,8	12,7	185



▣ J.F - Nasadki 3/8" przegubowe 12-kątne calowe

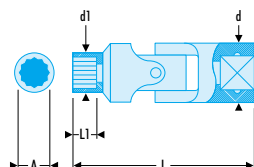

ASME B107.1

- Profil OGV®: większa siła i bezpieczeństwo, ochrona nakrętek.
- Kompaktowe rozwiązanie pozwalające na uniknięcie użycia przegubu.
- Wykończenie: chromowane błyszczące.

➤	A ["]	⚙ [mm]	d [mm]	d1 [mm]	L [mm]	L1 [mm]	ΔΔ [g]
J.3/8F	3/8	12	19	14,0	47,5	8,3	55
J.7/16F	7/16	12	19	15,8	49,0	9,8	55
J.1/2F	1/2	12	19	18,3	50,5	11,3	60
J.9/16F	9/16	12	19	19,5	50,5	11,3	60
J.5/8F	5/8	12	19	22,00	53,5	12,8	70
J.11/16F	11/16	12	19	24,00	54,5	13,8	72
J.3/4F	3/4	12	19	25,8	56,5	15,8	80

Nasadki 3/8" Torx®

▣ JTX - Nasadki 3/8" Torx®

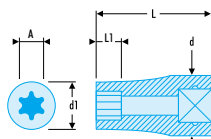

- Do śrub trzpieniowych Torx®.
- Dostępne w zestawie na stojaku metalowym (symbol JTX.40).
- Wykończenie: chromowane błyszczące.

➤	A [mm]	Torx [Nr]	d [mm]	d1 [mm]	L [mm]	L1 [mm]	ΔΔ [g]
JTX.8	7,29	E8	17,3	9,9	26	5,6	40
JTX.10	9,19	E10	17,3	11,8	26	6,4	40
JTX.12	10,95	E12	17,3	14,5	26	8,0	40
JTX.14	12,67	E14	17,3	15,7	26	8,8	50
JTX.16	14,70	E16	17,3	18,0	26	9,6	100

Nasadki trzpieniowe 3/8"

▣ JT - Nasadki trzpieniowe 3/8" do śrub 6-kątnych metrycznych

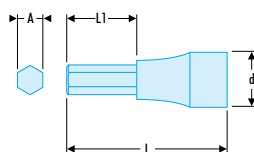

- Demontowalne końcówki.
- Nasadka J.235.
- Wykończenie: chromowane błyszczące z końcówką fosforanowaną.
- Dostępne w zestawie na stojaku metalowym: Symbol JT.40.

➤	A [mm]	d [mm]	Końcówki	L [mm]	L1 [mm]	ΔΔ [g]
JT.3	3	18	EH.103	45,0	15,0	31
JT.4	4	18	EH.104	45,0	15,0	31
JT.5	5	18	EH.105	45,0	15,0	32
JT.6	6	18	EH.106	45,0	15,0	33
JT.7	7	18	EH.107	45,0	15,0	34
JT.8	8	18	EH.208	47,5	17,5	43
JT.10	10	18	EH.210	47,5	17,5	50

■ JT - Nasadki trzpieniowe 3/8" do śrub 6-kątnych calowych

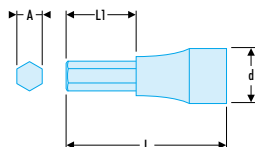

- Demontowalne końcówki.
- Nasadki J.235.
- Wykończenie: chromowane błyszczące z końcówką fosforanową.
- Dostępne w zestawie na stojaku metalowym (JT.40).

⇒	A ["]	d [mm]	Końcówki	L [mm]	L1 [mm]	ΔΔ [g]
JT.1/8	3,17	18	EH.101/8	45	15,0	31
JT.5/32	3,96	18	EH.105/32	45	15,0	31
JT.3/16	4,76	18	EH.103/16	45	15,0	31
JT.7/32	5,56	18	EH.107/32	45	15,0	32
JT.1/4	6,35	18	EH.101/4	45	15,0	33
JT.5/16	7,94	18	EH.205/16	47,5	17,5	43
JT.3/8	9,53	18	EH.203/8	47,5	17,5	50

■ JX: nasadka trzpieniowe 3/8" do końcówek Torx®

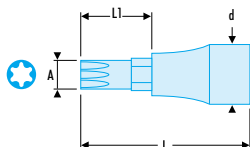

- Demontowalne końcówki.
- Nasadka J.236.
- Wykończenie: chromowane błyszczące z końcówką fosforanową.

⇒	A [mm]	Torx [Nr]	Końcówki	L [mm]	L1 [mm]	ΔΔ [g]
JX.10	2,72	T10	EX.110	46,0	16,0	33,50
JX.15	3,26	T15	EX.115	46,0	16,0	33,50
JX.20	3,84	T20	EX.120	46,0	16,0	33,50
JX.25	4,40	T25	EX.125	46,0	16,0	33,50
JX.27	4,96	T27	EX.127	46,0	16,0	33,50
JX.30	5,49	T30	EX.130	46,0	16,0	33,50
JX.40	6,60	T40	EX.140	52,5	22,5	45,00
JX.45	7,77	T45	EX.145	52,5	22,5	45,00
JX.50	8,79	T50	EX.150	52,5	22,5	47,50
JX.55	11,17	T55	EX.155	52,5	22,5	61,00

PRZYGOTUJ WŁASNY ZESTAW NASADEK - KOŃCÓWEK

Końcówki do przykręcania



- Seria 1 \square 1/4"
- Seria 2 \square 5/16"

➤ Patrz rozdział 7

Uchwyt końcówek
□ 3/8"



J.235
 \square 1/4"
6,35 mm











J.236
 \square 5/16"
7,94 mm

➤ Patrz str. 270



ZESTAWY NASADEK 1/2" „DETECTION BOX” WYMIARY METRYCZNE

		SL.DBOX1	SL.DBOX112	SL.DBOX4	SL.DBOX412
  Typ nasadki		SL.161 Standard	SL.161 Standard	SL.161 Standard	SL.161 Standard
 mm	8	•	•	•	•
	9			•	•
	10	•	•	•	•
	11	•	•	•	•
	12	•	•	•	•
	13	•	•	•	•
	14	•	•	•	•
	15	•	•	•	•
	16	•	•	•	•
	17	•	•	•	•
	18	•	•	•	•
	19	•	•	•	•
	21	•	•	•	•
	22	•	•	•	•
23			•	•	
24	•	•	•	•	
27	•	•	•	•	
30	•	•	•	•	
32	•	•	•	•	
 S.210S S.120A  S.240A  S.215  S.210			•	•	
				•	•
			•	•	
			•	•	
			•	•	
 BV.S1NANO		BV.S2NANO			
		340 x 180 x 58 mm			
		3,680 Kg		3,750 Kg	

SL.DBOX1



SL.DBOX112



SL.DBOX4















SL.DBOX412



ZESTAWY NASADEK 1/2" „DETECTION BOX”

WYMIARY METRYCZNE

		S.360DBOX1	S.360DBOX112	S.360DBOX4	S.360DBOX412	S.DBOX500	S.DBOX501
  Typ nasadki		S.360 Standard	S.360 Standard	S.360 Standard	S.360 Standard	S.171 Standard	S.171 Standard
 mm	8	•	•	•	•	•	•
	9	•	•	•	•	•	•
	10	•	•	•	•	•	•
	11	•	•	•	•	•	•
	12	•	•	•	•	•	•
	13	•	•	•	•	•	•
	14	•	•	•	•	•	•
	15	•	•	•	•	•	•
	16	•	•	•	•	•	•
	17	•	•	•	•	•	•
	18	•	•	•	•	•	•
	19	•	•	•	•	•	•
	21	•	•	•	•	•	•
	22	•	•	•	•	•	•
23	•	•	•	•	•	•	
24	•	•	•	•	•	•	
27	•	•	•	•	•	•	
30	•	•	•	•	•	•	
32	•	•	•	•	•	•	
     	S.210S			•	•		
	S.120A			•	•		
	S.240A	•	•			•	•
	S.215A	•	•				
	S.215RC					•	•
	S.210	•	•				
S.210RC					•	•	
  		BV.S1NANO		BV.S2NANO		BV.S1NANO	
		340 x 480 x 58 mm				340 x 480 x 58 mm	
		3,890 Kg				3,740 Kg	

S.360DBOX1



S.360DBOX112



S.360DBOX4



S.360DBOX412















S.DBOX500



S.DBOX501



ZESTAWY NASADEK 1/2" „KLASYCZNE” WYMIARY METRYCZNE

		S.420B	S.423AP	S.422AP	S.200DP	S.600
  Typ nasadki		S.151 Standard	S.161 Standard	S.161 Standard	S.161 Standard	S.161 Standard
 mm	8		•	•		•
	9		•	•		•
	10	•	•	•	•	•
	11	•	•	•	•	•
	12	•	•	•	•	•
	13	•	•	•	•	•
	14	•	•	•	•	•
	15	•	•	•	•	•
	16	•	•	•	•	•
	17	•	•	•	•	•
	18	•	•	•	•	•
	19	•	•	•	•	•
	20					
	21	•	•	•	•	•
	22	•	•	•	•	•
	23					
	24	•	•	•	•	•
26						
27				•	•	
28						
29						
30				•	•	
32				•	•	
34						
      	S.210		•	•	•	
	S.215	•	•	•	•	•
	S.240A		•	•	•	•
	S.120A					
	S.110					
	S.210RC					
S.215RC						
  		PL.423	PL.422	PL.422	PL.618	PL.619
			BR.112			
			389 x 164 x 66 mm			
		2,33 Kg	2,92 Kg		3,45 Kg	

S.420B



S.423AP
S.422AP



S.200DP















S.600



ZESTAWY NASADEK 1/2" „KLASYCZNE”

WYMIARY METRYCZNE

		S.429EP	S.428EP	S.431ADP	S.430ADP	S.441AP	S.440AP
		S.161	S.161	S.161	S.161	S.161	S.161
		Standard	Standard	Standard	Standard	Standard	Standard
 mm	8					•	•
	9					•	•
	10	•	•	•	•	•	•
	11	•	•	•	•	•	•
	12	•	•	•	•	•	•
	13	•	•	•	•	•	•
	14	•	•	•	•	•	•
	15	•	•	•	•	•	•
	16						
	17	•	•	•	•	•	•
	18						
	19	•	•	•	•	•	•
	20						
	21		•	•	•	•	•
	22	•	•	•	•	•	•
	23						
	24	•	•	•	•	•	•
26							
27	•	•	•	•	•	•	
28							
29							
30	•	•	•	•	•	•	
32	•	•	•	•	•	•	
34							
 S.210		•	•	•	•	•	•
 S.215		•	•	•	•	•	•
 S.240A		•	•	•	•	•	•
 S.120A		•	•	•	•	•	•
 S.110						•	•
 PL.10A		PL.10A					
 PL.701				PL.701			
 BP.109				BP.109			
 478 x 234 x 72 mm				478 x 234 x 72 mm			
 4,03 Kg		4,03 Kg					
 4,88 Kg				4,88 Kg			
 5,95 Kg						5,95 Kg	

S.429EP
S.428EP ▼















S.431ADP
S.430ADP ▼



S.441AP
S.440AP ▼



ZESTAWY NASADEK 1/2" „KLASYCZNE” WYMIARY METRYCZNE

		S.441E	S.440E	S.800	S.900	S.447DP	S.446DP	
		S.151 6	S.151 12	S.161 6	S.161 6	S.161 6	S.161 12	
Typ nasadki		Standard	Standard	Standard	Standard	Standard	Standard	
	mm	8	•	•	•	•	•	
		9	•	•	•	•	•	
		10	•	•	•	•	•	
		11	•	•	•	•	•	
		12	•	•	•	•	•	
		13	•	•	•	•	•	
		14	•	•	•	•	•	
		15	•	•	•	•	•	
		16	•	•	•	•	•	
		17	•	•	•	•	•	
		18	•	•	•	•	•	
		19	•	•	•	•	•	
		20	•	•	•	•	•	
		21	•	•	•	•	•	
		22	•	•	•	•	•	
		23	•	•	•	•	•	
		24	•	•	•	•	•	
26	•	•	•	•	•			
27	•	•	•	•	•			
28	•	•	•	•	•			
29	•	•	•	•	•			
30	•	•	•	•	•			
32	•	•	•	•	•			
34	•	•	•	•	•			
	EP +	1		•	•			
		2			•	•		
		3			•	•		
	EH mm	3						
		4			•	•		
		5			•	•		
		6			•	•	•	
		10			•	•	•	
	ED +	1		•				
		2			•			
		3			•			
	ES -	4,5		•	•			
		6,5			•	•		
		8			•	•		
		10			•	•		
	EHL mm	4		•	•			
		5			•	•		
		6			•	•		
		7			•	•		
		10			•	•		
	EX +	20		•	•			
		25			•	•		
		27			•	•		
		30			•	•		
		40			•	•		
		45			•	•		
	EXL +	30			•			
		40			•	•		
		45			•	•		
		50			•	•		
	ENH	12				•	•	
		24					•	•
	S.206 S.208 S.210 S.210S S.215 S.240A S.120A S.110 S.236 S.237			•				
					•			
				•			•	•
				•			•	•
				•			•	•
				•			•	•
				•			•	•
				•			•	•
		PL.708		PL.706	PL.705		PL.291A	
					BP.109			
		5,95 Kg		4,70 Kg	7,30 Kg		5,00 Kg	
					478 x 234 x 72 mm			

**S.441E
S.440E**



S.800





















S.900



**S.447DP
S.446DP**



ZESTAWY NASADEK 1/2" „KLASYCZNE” WYMIARY METRYCZNE

		S.442EP	SM.440EP	SM.441EP	S.450EP
		S.161	SL.161	SL.161	S.161
Typ nasadki		Standard	Standard	Standard	Standard: Długie
	mm				
	7				
	8	•	•	•	•
	9	•	•	•	•
	10	•	•	•	•
	11	•	•	•	•
	12	•	•	•	•
	13	•	•	•	•
	14	•	•	•	•
	15	•	•	•	•
	16	•	•	•	•
	17	•	•	•	•
	18	•	•	•	•
	19	•	•	•	•
	21	•	•	•	•
	22	•	•	•	•
	23	•	•	•	•
24	•	•	•	•	
26	•	•	•	•	
27	•	•	•	•	
28	•	•	•	•	
29	•	•	•	•	
30	•	•	•	•	
32	•	•	•	•	
34	•	•	•	•	
	3				•
	4				•
	314				•
	316				•
	S.210	•	•	•	•
	S.215	•	•	•	•
	S.240A	•	•	•	•
	S.120A	•	•	•	•
	S.110	•	•	•	•
	S.236				•
	S.237				•
	S.234				•
	S.141A				•
	P.21		PL.708	PLT.11, PL.23, PL.24A	
	BT.6A		BP.109	BP.108	
	468 x 190 x 160 mm		478 x 234 x 72 mm	452 x 284 x 111 mm	
	7,68 Kg		6,05 Kg	14,86 Kg	

S.442EP









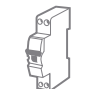









SM.440EP
SM.441EP



S.450EP

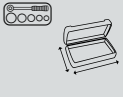

ZESTAWY NASADEK 1/2" „KLASYCZNE” WYMIARY CALOWE

		S.420AU	S.441AUP	S.440AUP	SL.441AUP	SL.440AUP	S.450UP
	S.151	S.161	S.161	SL.161	SL.161	S.161+S.156	
	Standard	Standard	Standard	Standard	Standard	Standard: Długie	
	"						
	3/8	•	•	•	•	•	
	7/16	•	•	•	•	•	
	1/2	•	•	•	•	•	
	9/16	•	•	•	•	•	
	19/32	•	•	•	•	•	
	5/8	•	•	•	•	•	
	21/32	•	•	•	•	•	
	11/16	•	•	•	•	•	
	3/4	•	•	•	•	•	
	25/32	•	•	•	•	•	
	13/16	•	•	•	•	•	
	7/8	•	•	•	•	•	
	15/16	•	•	•	•	•	
	31/32	•	•	•	•	•	
	1'	•	•	•	•	•	
	1 1/16	•	•	•	•	•	
	1 1/8	•	•	•	•	•	
	1 1/4	•	•	•	•	•	
	3					•	
	4					•	
	314					•	
	316					•	
	S.210		•	•	•	•	
	S.215	•	•	•	•	•	
	S.240A		•	•	•	•	
	S.120A	•	•	•	•	•	
	S.110		•	•	•	•	
	S.236					•	
	S.237					•	
	S.234					•	
	S.141A					•	
	PL.415	PL.702	PL.702	PL.702	PL.702	PLT.11, PL.23, PL.24A	
	BP.112	BP.109	BP.109	BP.109	BP.109	BT.108	
	389x164x66 mm	478x234x72 mm	478x234x72 mm	478x234x72 mm	478x234x72 mm	452x284x111 mm	
	2,43 Kg	5,18 Kg	5,13 Kg	5,13 Kg	5,13 Kg	13,03 Kg	

S.420AU



**S.441AUP
S.440AUP**



**SL.441AUP
SL.440AUP**



S.450UP



ZESTAWY NASADEK 1/2"

SKRZYNKI KLASYCZNE

		S.401A	S.400A	S.405E	S.404E	STM.J9	AMEX.3
						-	-
Typ nasadki		Standard	Standard	Długie	Długie	Nasadka do wkrętek sześciokątna	Nasadka do wkrętek TORX®
	8	•	•				
	9	•	•				
	10	•	•				
	11	•	•				
	12	•	•	•	•		
	13	•	•	•	•		
	14	•	•	•	•		
	15	•	•	•	•		
	16	•	•	•	•		
	17	•	•	•	•		
	18	•	•	•	•		
	19	•	•	•	•		
	21	•	•	•	•		
	22	•	•	•	•		
	23	•	•	•	•		
24	•	•	•	•			
26	•	•	•	•			
27	•	•	•	•			
28	•	•	•	•			
29	•	•	•	•			
30	•	•	•	•			
32	•	•	•	•			
	STM.5					•	
	STM.6					•	
	STM.7					•	
	STM.8					•	
	STM.10					•	
	STM.12					•	
	STM.14					•	
	STM.17					•	
	STM.19					•	
	SXM.20						•
	SXM.25						•
	SXM.27						•
	SXM.30						•
	SXM.40						•
	SXM.45						•
	SXM.50						•
	SXM.55						•
SXM.60						•	
		PL.413		PL.52B		PL.458	PL.455
		BP.112		BP.109		BP.102	
		389 x 164 x 66 mm		478 x 234 x 72 mm		204 x 122 x 52 mm	
		2,69 Kg		4,65 Kg		0,865 Kg	

S.401A
S.400A



S.405E
S.404E





STM.J9

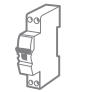
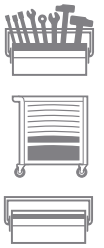

AMEX.3



ZESTAWY NASADEK 1/2" NA SZYNACH METALOWYCH

		S.40E	S.41E	S.40U	S.41U	STX.40	RSX.J6
		Standard	Standard	Standard	Standard	TORX Standard	TORX Standard 1/4" + 1/2"
 mm	7						
	8	•					
	9	•					
	10	•					
	11	•					
	12	•					
	13	•					
	14	•					
	15	•					
	16	•					
	17		•				
	18		•				
	19		•				
	21		•				
	22		•				
	23		•				
24		•					
 "	3/8			•			
	7/16			•			
	1/2			•			
	9/16			•			
	19/32			•			
	5/8			•			
	21/32			•			
	11/16				•		
	3/4				•		
	13/16				•		
	7/8				•		
	15/16				•		
	1"				•		
Nasadki TORX®	E.6						•
	E.8						•
	E.10						•
	E.12					•	•
	E.14					•	•
	E.16					•	•
	E.18					•	•
E.20					•	•	
		CKS.95	CKS.95	CKS.97	CKS.95	CKS.90	CKS.98
		0,570 Kg	0,69 Kg	0,465 Kg	0,350 Kg	0,320 Kg	0,205 Kg

S.40E
S.41E
S.40U
S.41U



STX.40



RSX.J6



ZESTAWY NASADEK 1/2" NA SZYNACH METALOWYCH

		ST.40	ST.41	SX.41	SV.40A	SV.41A	SV.J8A	SV.LJ6A
Nasadki do wkrętek								
STM	STM.6	•						
	STM.8	•						
	STM.10	•						
	STM.12	•						
	STM.14	•						
	STM.17	•						
	STM.19	•						
SXM	SXM.20			•				
	SXM.25			•				
	SXM.27			•				
	SXM.30			•				
	SXM.40			•				
	SXM.45			•				
	SXM.50			•				
	SXM.55			•				
SHPLA: nasadka do wkrętek, długa do śrub z łbem drążonym 6-kątnym	SHPLA.6		•					
	SHPLA.7		•					
	SHPLA.8		•					
	SHPLA.10		•					
SHPLA.12		•						
SVLB: nasadka do wkrętek o różnych grotach XZN	SV.6LB					•	•	
	SV.8LB					•	•	
	SV.10LB					•	•	
	SV.12LB					•	•	
SVB: nasadka do wkrętek o różnych grotach XZN	SV.6B				•	•	•	
	SV.8B				•	•	•	
	SV.10B				•	•	•	
	SV.12B				•	•	•	
Nasadka ekstra długa do wkrętek z różnymi grotami XCN	SV.10ELB							•
	SV.12ELB							•
CKS	CKS.97	CKS.90	CKS.95	CKS.90		PL.247	PL.258	
	0,830 Kg	0,61 Kg	0,64 Kg	0,34 Kg	0,44 Kg	220x136x28 mm 0,805 Kg	170x170x34 mm 0,80 Kg	

ST.40



ST.41



SX.41



SV.40A
SV.41A



SV.J8A





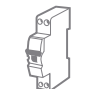





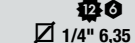
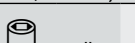
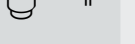





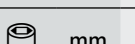
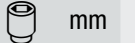

SV.LJ6A



MODUŁY 1/2"

WKŁADKI TERMOFORMOWANE

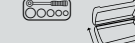
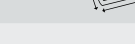
		MOD.SL1	MOD.S1	MOD.S2	MOD.HLA		
		SL.161	S.161	S.161			
		Standard	Standard	Standard	Długie	Długie	
            	3/8			•			
	"	7/16			•		
		1/2			•		
		9/16			•		
		19/32			•		
		5/8			•		
		21/32			•		
		11/16			•		
		3/4			•		
		25/32			•		
		13/16			•		
		7/8			•		
		15/16					
		31/32					
		1					
		1 1/16					
	1 1/8						
	1 1/4						
  	7					•	
	8					•	
	9					•	
	S.10H	•	•			•	
	S.11H	•	•		1/2	•	
	S.12H	•	•		•	3/8	
	S.13H	•	•		•		
	S.14H	•	•		•		
	S.15H	•	•		•		
	S.16H	•	•		•		
	S.17H	•	•		•		
	S.18H	•	•		•		
S.19H	•	•		•			
S.21H	•	•					
S.22H	•	•					
S.23H	•	•					
S.24H	•	•					
S.27H	•	•					
S.30H	•	•					
S.32H	•	•					
    	S.210	•	•	•			
	S.215	•	•	•			
	S.240A	•	•	•			
	S.120A						
	S.236						
S.232B							
S.230	•						
 	PL.687	PL.323	PL.604	PL.609			
	435x198x55 mm 3,36 Kg	420x180x55 mm 3,32 Kg	420x180x55 mm 2,95 Kg	420x180x55 mm 1,62 Kg			

MOD.SL1



MOD.S1



MOD.S2



MOD.HLA



MODUŁY 1/2"

WKŁADKI TERMOFORMOWANE

inne	MOD.TX1		MOD.CH	MOD.SHP
	TORX® JTX Standard	TORX® STX Standard	Nasadka do wkrętek TORX® + XZN Standard + długa	Nasadka do wkrętek TORX® + XZN Długa
	D.34B7L D.34B9L D.34B10L D.34B12L D.34B14L D.34B16L		• • • • • •	
JTX 3/8"	JTX.8 JTX.10 JTX.12 JTX.14 JTX.16	• • • • •	• •	
SHP: nasadka trzpieniowa długa TORX®	SHP.5LA SHP.6LA SHP.7LA SHP.8LA SHP.10LA SHP.12LA		• • • • • •	• • • •
STX	STX.12 STX.14 STX.16 STX.18 STX.20	• •	• • • • •	
SVB: nasadka końcówka trzpieniowa TORX® długa	SV.6LB SV.8LB SV.10ELB SV.12ELB SV.14ELB		• • • • •	• • • • •
SX: końcówka trzpieniowa TORX® długa	SX.40LA SX.45LA SX.55LA SX.70LA		• • •	• • •
EXR	10 15 20 25 30 40	• • • • • •		
EX	40 45 50 55	• • • •		
59TX: klucze oczkowe TORX®	6x8 10x12 14x18 20x27	• • • •		
	R.235 S.236 J.235	• • •		
	PL.360		PL.663	PL.336
	420 x 180 x 55 mm 0,99 Kg			

MOD.TX1



MOD.CH

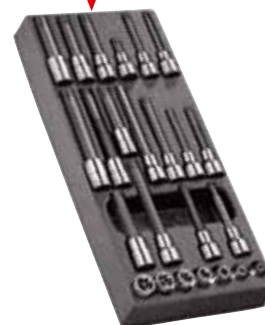









MOD.SHP



MODUŁY 1/2"

WKŁADKI PIANKOWE DWUKOLOROWE

		MODM.SL1	MODM.S1A	MODM.HLA
		SL.161	S.161	-
		Std	Std	Długie
 mm	8	•	•	3/8"+1/2"
	9			
	10	•	•	
	11	•	•	
	12	•	•	
	13	•	•	
	14	•	•	
	15	•	•	
	16	•	•	
	17	•	•	
	18	•	•	
	19	•	•	
	20			
	21	•	•	
	22	•	•	
	23	•	•	
	24	•	•	
	27	•	•	
	28			
	29			
30	•	•		
32	•	•		
34				
Nasadki długie 1/2"	S.12HLA			•
	S.13HLA			•
	S.14HLA			•
	S.15HLA			•
	S.16HLA			•
	S.17HLA			•
	S.18HLA			•
S.19HLA			•	
Nasadki długie 3/8"	J.7HLA			•
	J.8HLA			•
	J.9HLA			•
	J.10HLA			•
	J.11HLA			•
   	S.210	•	•	
	S.215	•	•	
	S.240A	•	•	
	S.120A	•	•	
		PM.S1A	PM.S1A	PM.MODHLA
		420 x 190 x 55 mm		
		3,40 Kg	3,45 Kg	

MODM.SL1



MODM.S1A



MODM.HLA



Grzechotki 1/2"

Grzechotka 1/2" szczelna o wysokich parametrach

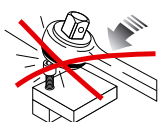
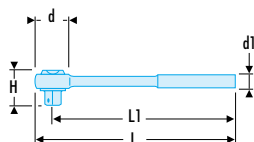

NF ISO 3315, ISO 3315, DIN 3122, ASME B107.10

- Bardzo wysoka trwałość bez konserwacji, niezależnie od warunków pracy.
- Szczelność na pyły, szlamy przemysłowe itp.
- Mechanizm z 72 zębami i skokiem co 5°.
- Odwracanie kierunku za pomocą dźwigni umożliwiającej wzrokową kontrolę kierunku obrotów.
- System „na docisk dłonią”, umożliwiający dociskanie główki grzechotki podczas dokręcania i odkręcania bez ryzyka przypadkowego odwrócenia kierunku obrotów.
- Główka ultra-kompaktowa.
- Oczko do zaczepiania do prac na wysokości.
- Wyjątkowa wygoda.

	d [mm]	d1 [mm]	H [mm]	L [mm]	L1 [mm]	ΔΔ [g]
SL.161	37	32	37	262	245	446

Grzechotka 1/2" szybka z rękojeścią obrotową

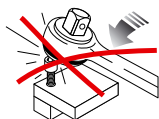
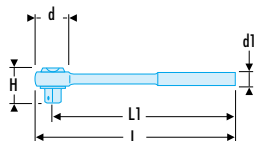

NF ISO 3315, ISO 3315, DIN 3122, ASME B107.10

- Grzechotka z 60 zębami w systemie „na docisk dłonią”.
- Skok zęba grzechotki.
- 0° przy obracaniu rękojeści.
- 6° przy użytkowaniu tradycyjnym.
- Okrągła główka grzechotki: przełączanie poprzez pierścieni.
- Zatrzask zabezpieczający.

	d [mm]	d1 [mm]	H [mm]	L [mm]	L1 [mm]	ΔΔ [g]
S.360	45	37	41	251	251	570

Grzechotka 1/2" „na docisk dłonią”.

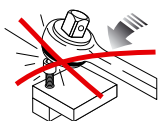
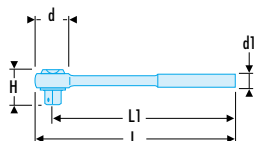

NF ISO 3315, ISO 3315, DIN 3122, ASME B107.10

- Mechanizm z 72 zębami o skoku 5°.
- System „na docisk dłonią”, umożliwiający dociskanie główki grzechotki podczas dokręcania i odkręcania bez ryzyka przypadkowego odwrócenia kierunku obrotów.
- Odwracanie kierunku za pomocą pierścienia.

	d [mm]	d1 [mm]	H [mm]	L [mm]	L1 [mm]	ΔΔ [g]
S.161	39	31	43	250	234	500



Grzechotka 1/2" klasyczna

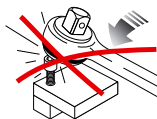
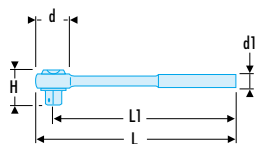

NF ISO 3315, ISO 3315, DIN 3122, ASME B107.10

- Mechanizm z 72 zębami o skoku 5°.
- Odwracanie kierunku za pomocą pierścienia obrotowego.

⇒	d [mm]	d1 [mm]	H [mm]	L [mm]	L1 [mm]	ΔΔ [g]
S.151	39	30	40	250	255	480

Grzechotka 1/2" z blokadą

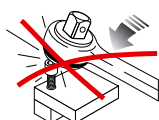
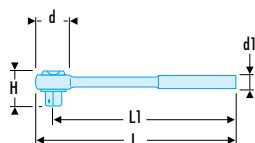

NF ISO 3315, ISO 3315, DIN 3122, ASME B107.10

- Mechanizm z 72 zębami o skoku 5°.
- System „na docisk dłonią”, umożliwiający dociskanie główki grzechotki podczas dokręcania i odkręcania bez ryzyka przypadkowego odwrócenia kierunku obrotów.
- Odwracanie kierunku za pomocą pierścienia.
- Blokada bezpieczeństwa nasadki: zapobiega zagubieniu nasadki w maszynach.

⇒	d [mm]	d1 [mm]	H [mm]	L1 [mm]	L2 [mm]	ΔΔ [g]
S.151	39	31	44	250	234	510

Grzechotka 1/2" długa

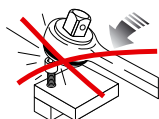
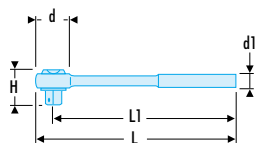

- Mechanizm z 72 zębami o skoku 5°.
- Odwracanie kierunku za pomocą pierścienia obrotowego.
- Długość: 400 mm (umożliwia przyłożenie wyższego momentu i zmniejsza zmęczenie).

⇒	d [mm]	d1 [mm]	H [mm]	L [mm]	L1 [mm]	ΔΔ [g]
S.154	40	30	40	404	38	780

Grzechotka 1/2" przegubowa

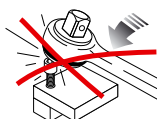
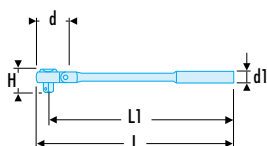

- Mechanizm z 72 zębami o skoku 5°.
- System „na docisk dłonią”, umożliwiający dociskanie główki grzechotki podczas dokręcania i odkręcania bez ryzyka przypadkowego odwrócenia kierunku obrotów.
- Odwracanie kierunku za pomocą pierścienia.
- Przegub hamowany umożliwiający zachowanie położenia nawet z założonym przedłużaczem i nasadką.

⇒	d [mm]	d1 [mm]	H [mm]	L [mm]	L1 [mm]	ΔΔ [g]
S.143A	38	31	42	265	247	598

Grzechotka 1/2" długa przegubowa

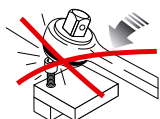
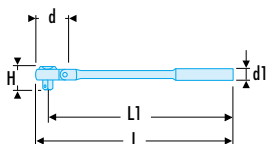

- Mechanizm z 72 zębami o skoku 5°.
- System „na docisk dłonią”, umożliwiający dociskanie główki grzechotki podczas dokręcania i odkręcania bez ryzyka przypadkowego odwrócenia kierunku obrotów.
- Odwracanie kierunku za pomocą pierścienia.
- Rękojeść ekstra-długa do przykładania wyższego momentu bez zmęczenia.
- Przegub hamowany umożliwiający zachowanie położenia nawet z założonym przedłużaczem i nasadką.

	d [mm]	d1 [mm]	H [mm]	L [mm]	L1 [mm]	ΔΔ [g]
S.153A	38	31	43	400	381	755

Grzechotka 1/2" długa przegubowa z rękojeścią metalową

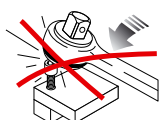
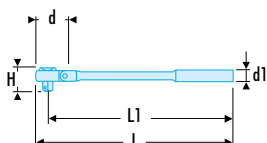

- Mechanizm z 72 zębami o skoku 5°.
- System „na docisk dłonią”, umożliwiający dociskanie główki grzechotki podczas dokręcania i odkręcania bez ryzyka przypadkowego odwrócenia kierunku obrotów.
- Odwracanie kierunku za pomocą pierścienia.
- Rękojeść ekstra-długa do przykładania wyższego momentu bez zmęczenia.
- Przegub hamowany umożliwiający zachowanie położenia nawet z założonym przedłużaczem i nasadką.
- Całkowicie metalowa rękojeść.

	d [mm]	d1 [mm]	H1 [mm]	L [mm]	ΔΔ [g]
S.158A	42	20	40	435	940

Grzechotka pośrednia 1/2"

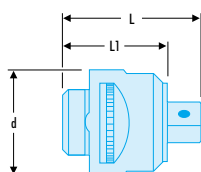



- Gniazdo zabieraka 1/2" kwadratowe.
- Zabierak kwadratowy 1/2".
- Skok zęba grzechotki co: 5°.
- Wykończenie: chromowane błyszczące z zabierakiem kwadratowym fosforanowanym.

	d [mm]	L [mm]	L1 [mm]	ΔΔ [g]
S.156	39	59	39	230



KONSERWACJA GRZECHOTEK 1/2"

	S.171	S.161	S.151	S.154	S.143A	S.153A	S.158A	S.156
Nakładki								
 S.161C		•			•	•	•	
S.151C			•	•				
S.156C								•
Zestaw części zamiennych								
 S.161RN		•			•	•	•	
S.151RN			•	•				•
Zabierak								
 S.151R		•	•	•	•	•	•	•

Akcesoria 1/2"

▣ Rękojeść przesuwna 1/2"

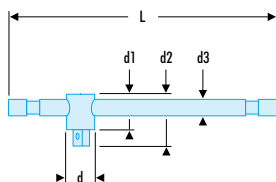

NF ISO 3315, ISO 3315, DIN 3122, ASME B107.10

- Hamulec umieszczony na główce rękojeści podtrzymuje położenie trzpienia przesuwnej, który dzięki temu może tworzyć klucz w kształcie T lub L.
- Wykończenie: chromowane błyszczące.

	d [mm]	d1 [mm]	d2 [mm]	d3 [mm]	L [mm]	ΔΔ [g]
S.120A	24	29	45	14	275	408

▣ Rękojeść przegubowa 1/2" długość standardowa

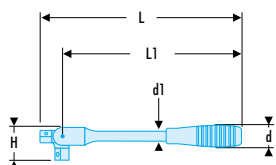

NF ISO 3315, ISO 3315, DIN 3122, ASME B107.10

- Przegub z hamowaniem.
- Wykończenie: chromowane błyszczące.

	d [mm]	d1 [mm]	H [mm]	L [mm]	L1 [mm]	ΔΔ [g]
S.140A	31	14	44	246	214,5	425

▣ Rękojeść przegubowa 1/2" długa

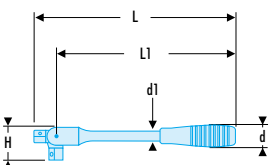

NF ISO 3315, ISO 3315, DIN 3122, ASME B107.10

- Przegub z hamowaniem.
- Wykończenie: chromowane błyszczące.

	d [mm]	d1 [mm]	H [mm]	L [mm]	L1 [mm]	ΔΔ [g]
S.141A	31	14	41	381	349,5	595

▣ Rękojeść przegubowa 1/2" długa z rękojeścią metalową

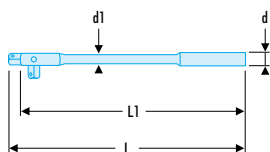

NF ISO 3315, ISO 3315, DIN 3122, ASME B107.10

- Przegub z hamowaniem.
- Rękojeść metalowa z uchwytem radełkowanym.
- Wykończenie: chromowane błyszczące.

🔧	d [mm]	d1 [mm]	L [mm]	L1 [mm]	ΔΔ [g]
S.145	20	15	410	392	740



▣ Korba 1/2"

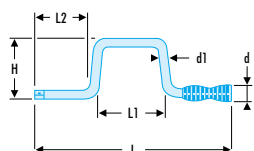

NF ISO 3315, ISO 3315, DIN 3122, ASME B107.10

- Narzędzie to umożliwia najszybsze dokręcanie w każdym wypadku, kiedy jego zastosowanie jest możliwe.
- Rękojeść obrotowa PCV.
- Wykończenie: chromowane błyszczące.

🔧	d [mm]	d1 [mm]	H [mm]	L [mm]	L1 [mm]	L2 [mm]	ΔΔ [g]
S.110	29	12	115	402	130	130	510



▣ Rękojeść z przegubem kardana 1/2"

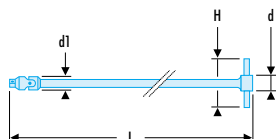
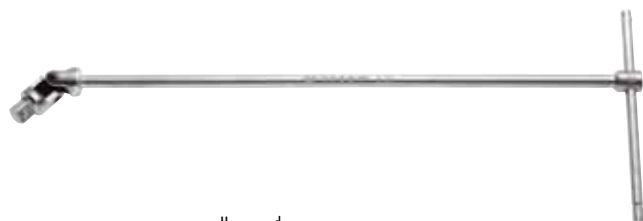

- Przegub o gwintowanych sworzniach dla wysokich momentów dokręcania.
- Wykończenie: chromowane błyszczące.

🔧	d [mm]	d1 [mm]	H [mm]	L [mm]	ΔΔ [g]
S.229A	18	24	180	495	550



▣ Rękojeść z przegubem kardana 1/2" ekstra-długa

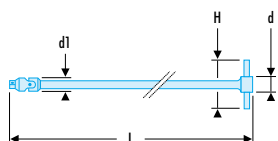

- Rękojeść w formie T umożliwia dostęp do głębokich miejsc dzięki swojej wyjątkowej długości.
- Wykończenie: chromowane błyszczące.

🔧	d [mm]	d1 [mm]	H [mm]	L [mm]	ΔΔ [kg]
S.228	24	25	240	700	1,20



■ S - Przedłużacze 1/2"

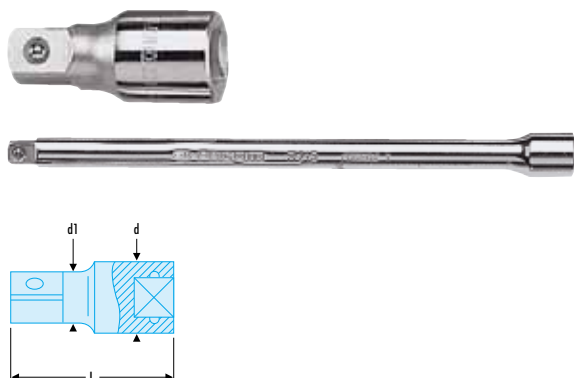

NF ISO 3316, ISO 3316, DIN 3123, ASME B107.10

- Wykończenie: chromowane błyszczące.

⇒	Kwadrat ["]	d [mm]	d1 [mm]	L [mm]	ΔΔ [g]
S.206	1/2	23	16,5	52,5	90
S.208	1/2	23	16,5	75	130
S.210	1/2	23	16,5	130	225
S.215	1/2	23	16,5	250	420
S.217	1/2	23	16,5	500	840

■ S.S - Przedłużacze kątowe 1/2"

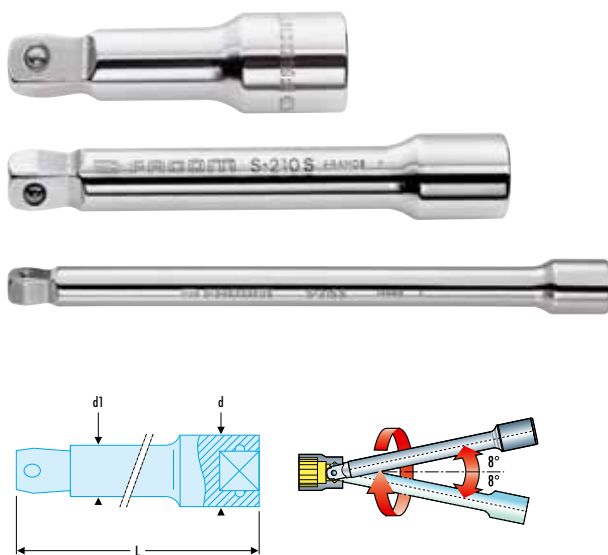

- Kulisty kształt zabieraka pozwala na odchylenie przedłużacza o 8° w stosunku do nasadki.

Pomyśl o przedłużaczu kątowym!

- Wykończenie: chromowane błyszczące.

⇒	Kwadrat ["]	d [mm]	d1 [mm]	L [mm]	ΔΔ [g]
S.208S	1/2	23	16,5	75	130
S.210S	1/2	23	16,5	130	225
S.215S	1/2	23	16,5	250	420

PRZEDŁUŻACZE KĄTOWE

**Element niedostępny za pomocą nasadki lub przegubu?
POMYŚL O PRZEDŁUŻACZU KĄTOWYM!**

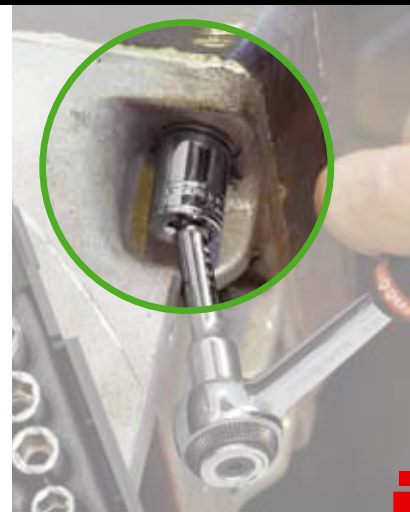
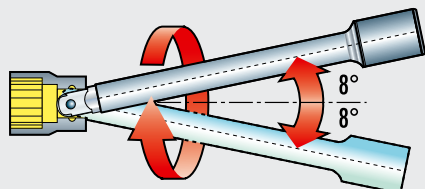

S.RC - Przedłużacz 1/2" z blokadą

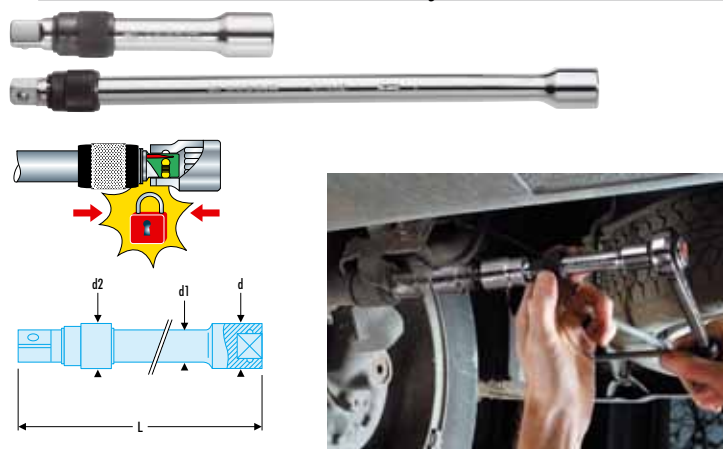

NF ISO 3316, ISO 3316, DIN 3123, ASME B107.10

- Całkowite bezpieczeństwo: mechanizm blokujący zapobiega przypadkowemu wypadnięciu nasadki.
- Zwiększone bezpieczeństwo i błyskawiczne odblokowanie przez cofnięcie pokrętki zapewniają wysoki komfort użytkownika.
- Całkowita blokada: użycie z nasadkami z rowkiem na kulkę.
- Wykończenie: chromowane błyszczące z pierścieniem radełkowym fosforanowanym.

	Kwadrat [°]	d [mm]	d1 [mm]	d2 [mm]	E [mm]	L [mm]	ΔΔ [g]
S.210RC	1/2	23	16,5	23	16,5	130	250
S.215RC	1/2	23	16,5	23	16,5	250	450
S.217RC	1/2	23	16,5	23	16,5	500	860

Przegub uniwersalny 1/2"

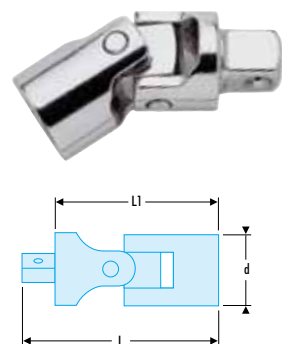

NF ISO 3316, ISO 3316, DIN 3123, ASME B107.10

- Przegub hamowany sprężynami.
- Pozostaje w pozycji początkowej podczas pracy w miejscach trudno przelozenie z 1/2" do 3/4"
- Pozwala na znaczną oszczędność czasu.
- Wykończenie: chromowane błyszczące.

	d [mm]	L [mm]	L1 [mm]	ΔΔ [g]
S.240A	23	66	51	150

Reduktor z 1/2" do 3/8"

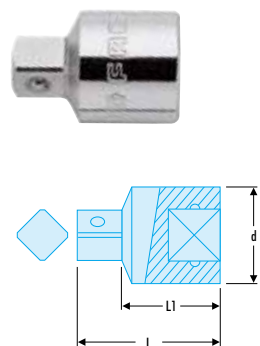

NF ISO 3316, ISO 3316, DIN 3123, ASME B107.10

- Gniazdo 1/2", zabierak CDX®.
- Maksymalny moment: 212 N.m.
- Wykończenie: chromowane błyszczące.

	d [mm]	L [mm]	L1 [mm]	ΔΔ [g]
S.230	23	33,5	23	55

Reduktor z 1/2" do CDX®

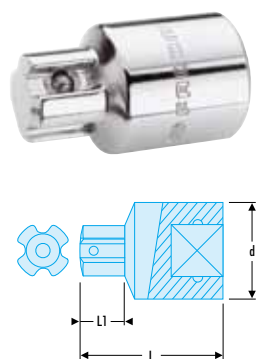

NF ISO 3316, ISO 3316, DIN 3123, ASME B107.10

- Gniazdo 1/2", zabierak CDX®.
- Reduktor dla podwójnych CDX®.
- Wykończenie: chromowane błyszczące.

	d [mm]	L [mm]	L1 [mm]	ΔΔ [g]
S.231	22	37	12	65



Przełożenie 1/2" do 3/4"

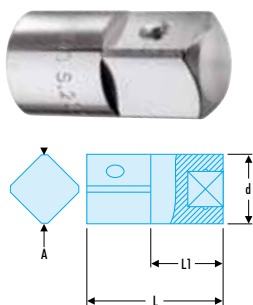

NF ISO 3316, ISO 3316, DIN 3123, ASME B107.10

- Gniazdo 1/2" i zabierak 3/4".
- Umożliwia stosowanie nasadek i akcesoriów 3/4".
- Zabierak kwadratowy z zaczepem do blokowania nasadek i akcesoriów.
- Wykończenie: chromowane satynowane.

➤	d [mm]	L [mm]	L1 [mm]	ΔΔ [g]
S.232B	25	49	26	135

D.169 Zestaw 3 adaptorów



- Rozpórki umożliwiają używanie narzędzi z zabierakiem o wymiarach mniejszych od nasadki:
 - Zabierak 1/4 + D.169RJ --> nasadka 3/8".
 - Zabierak 3/8 + D.169JS --> nasadka 1/2".
 - Zabierak 1/2 --> nasadka 3/4".
 - Małe wymiary zewnętrzne pozwalające zredukować ilość narzędzi potrzebnych przy interwencjach serwisowych.
 - Mocowanie magnetyczne i blokada (JS i SK).
 - Pierścień ryflowany umożliwiający dotarcie do miejsc trudno dostępnych.
- Masa: 96 g.

Przekładka zabierakowa 1/2"

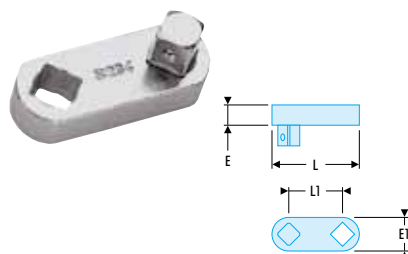

- Gniazdo 1/2", zabierak 1/2".
- Pozwala na dokręcanie trudno dostępnych nakrętek dzięki przesunięciu osi kluczy.
- Wykończenie: chromowane błyszczące.

➤	E [mm]	E1 [mm]	L [mm]	L1 [mm]	ΔΔ [g]
S.234	15	25	65	40	165

S - Nasadki 1/2" z uchwytem do końcówek i pierścieniem sprężynującym

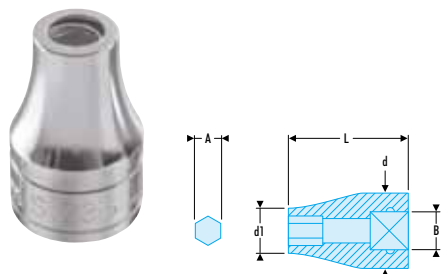

NF ISO 2725-1, NF ISO 1173, ISO 2725-1, ISO 1173, DIN 3124,

- S.236: do końcówek 5/16".
- S.237: do końcówek 1/2".
- Wykończenie: chromowane błyszczące.

➤	A ["]	Vierkant ["]	d [mm]	d1 [mm]	L [mm]	ΔΔ [g]
S.236	5/16	1/2	23,0	14	36	54
S.237	1/2	1/2	23	20,5	44	70

Nasadka 1/2" z uchwytem do końcówek z pierścieniem blokującym



NF ISO 2725-1, NF ISO 1173, ISO 2725-1, ISO 1173, DIN 3124,

- Blokowanie końcówki.
- Końcówka kwadratowa wyposażona w otwór na zatrask kulkowy lub zaczep.

➤	A ["]	Kwadrat ["]	L [mm]	ΔΔ [g]
EF.S	1/4	1/2	50	88

Nasadki 1/2"

■ S.H - Nasadki 1/2" 6-kątne metryczne

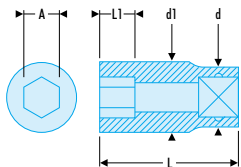

NF ISO 2725-1, NF ISO 1711-1, ISO 2725-1, ISO 1711-1, DIN 3124, ASME B107.5

- Profil OGV®: większa siła i bezpieczeństwo, ochrona nakrętek.
- Wykończenie: chromowane błyszczące.

⇒	A [mm]	⌀ [mm]	d [mm]	d1 [mm]	L [mm]	L1 [mm]	ΔΔ [g]
S.8H	8	6	22,8	13,1	36	6,5	48
S.9H	9	6	22,8	13,8	36	6,5	48
S.10H	10	6	22,8	15,3	36	7,8	48
S.11H	11	6	22,8	16,5	36	9,0	51
S.12H	12	6	22,8	17,8	36	9,5	52
S.13H	13	6	22,8	18,9	36	10,4	55
S.14H	14	6	22,8	20,2	36	10,5	57
S.15H	15	6	22,8	21,4	36	12,0	60
S.16H	16	6	21,6	22,6	36	12,0	57
S.17H	17	6	23,1	24,1	36	13,0	61
S.18H	18	6	23,4	25,5	36	13,0	68
S.19H	19	6	24,6	26,6	36	14,0	69
S.20H	20	6	25,4	27,4	36	14,0	71
S.21H	21	6	25,1	29,1	38	16,0	93
S.22H	22	6	26,4	30,4	38	16,5	101
S.23H	23	6	27,6	31,6	38	16,5	122
S.24H	24	6	28,7	32,7	38	16,5	130
S.25H	25	6	27,7	34,1	38	16,5	139
S.26H	26	6	29,0	35,4	38	16,5	149
S.27H	27	6	29,2	36,6	44	19,0	164
S.28H	28	6	30,5	37,9	44	20,0	175
S.29H	29	6	31,3	38,7	44	20,0	179
S.30H	30	6	33,0	40,4	44	20,0	201
S.31H	31	6	34,2	41,6	44	20,0	205
S.32H	32	6	35,1	42,6	44	20,0	215
S.34H	34	6	37,5	44,9	44	20,0	240

■ S.H - Nasadki 1/2" 6-kątne calowe

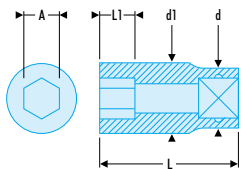

ASME B107.1

- Profil OGV®: większa siła i bezpieczeństwo, ochrona nakrętek.
- Wykończenie: chromowane błyszczące.

⇒	A ["]	⌀ [mm]	d [mm]	d1 [mm]	L [mm]	L1 [mm]	ΔΔ [g]
S.3/8H	3/8	6	22,8	14,7	36	7,8	48
S.7/16H	7/16	6	22,8	16,5	36	9,0	51
S.1/2H	1/2	6	22,8	18,9	36	10,4	55
S.9/16H	9/16	6	22,8	20,2	36	10,5	58
S.19/32H	19/32	6	22,8	21,4	36	12,0	60
S.5/8H	5/8	6	21,6	22,6	36	12,0	65
S.21/32H	21/32	6	23,1	24,1	36	13,0	65
S.11/16H	11/16	6	22,6	24,6	36	13,0	71
S.3/4H	3/4	6	25,0	27,0	36	14,0	68
S.25/32H	25/32	6	25,9	27,9	36	14,0	72
S.13/16H	13/16	6	24,6	28,6	38	16,0	96
S.7/8H	7/8	6	26,4	30,4	38	16,5	99
S.15/16H	15/16	6	28,7	32,7	38	16,5	132
S.31/32H	31/32	6	27,7	34,1	38	16,5	142
S.1"H	1	6	28,3	34,7	38	16,5	152
S.1"1/16H	1 1/16	6	29,2	36,6	44	19,0	164
S.1"1/8H	1 1/8	6	31,3	38,7	44	20,0	182
S.1"3/16H	1 3/16	6	33,0	40,4	44	20,0	201
S.1"1/4H	1 1/4	6	35,1	42,5	44	20,0	229



■ S - Nasadki 1/2" 12-kątne metryczne

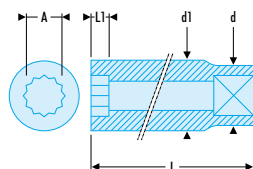

NF ISO 2725-1, NF ISO 1711-1, ISO 2725-1, ISO 1711-1, DIN 3124, ASME B107.5

- Profil OGV®: większa siła i bezpieczeństwo, ochrona nakrętek.
- Wykończenie: chromowane błyszczące.
- Dostępne na stojaku metalowym: Symbol S.40E (8 --> 16 mm) i symbol S.41E (17 --> 24 mm).

⇒	A [mm]	⊘ [mm]	d [mm]	d1 [mm]	L [mm]	L1 [mm]	ΔΔ [g]
S.8	8	12	22,8	13,1	36	6,5	48
S.9	9	12	22,8	13,8	36	6,5	48
S.10	10	12	22,8	15,3	36	7,8	48
S.11	11	12	22,8	16,5	36	9,0	51
S.12	12	12	22,8	17,8	36	9,5	52
S.13	13	12	22,8	18,9	36	10,4	55
S.14	14	12	22,8	20,2	36	10,5	57
S.15	15	12	22,8	21,4	36	12,0	60
S.16	16	12	21,6	22,6	36	12,0	57
S.17	17	12	23,1	24,1	36	13,0	61
S.18	18	12	23,4	25,4	36	13,0	68
S.19	19	12	24,6	26,6	36	14,0	69
S.20	20	12	25,4	27,4	36	14,0	71
S.21	21	12	25,1	29,1	38	16,0	93
S.22	22	12	26,4	30,4	38	16,5	101
S.23	23	12	27,6	31,6	38	16,5	122
S.24	24	12	28,7	32,7	38	16,5	130
S.25	25	12	27,7	34,1	38	16,5	128
S.26	26	12	29,0	35,4	38	16,5	138
S.27	27	12	29,2	36,6	44	19,0	142
S.28	28	12	30,5	37,9	44	20,0	163
S.29	29	12	31,3	38,7	44	20,0	167
S.30	30	12	33,0	40,4	44	20,0	185
S.31	31	12	34,2	41,6	44	20,0	189
S.32	32	12	35,1	42,5	44	20,0	198
S.34	34	12	37,5	44,9	44	20,0	223

■ S - Nasadki 1/2" 12-kątne calowe

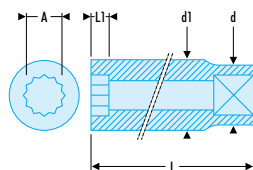

ASME B107.1

- Profil OGV®: większa siła i bezpieczeństwo, ochrona nakrętek.
- Wykończenie: chromowane błyszczące.
- Dostępne w zestawie na stojaku metalowym: Symbol S.40U (3/8" --> 21/32") i symbol S.41U (11/16" --> 1").

⇒	A ["]	⊘ [mm]	d [mm]	d1 [mm]	L [mm]	L1 [mm]	ΔΔ [g]
S.3/8	3/8	12	22,8	14,7	36	7,8	48
S.7/16	7/16	12	22,8	16,5	36	9,0	51
S.1/2	1/2	12	22,8	18,9	36	10,4	55
S.9/16	9/16	12	22,8	20,2	36	10,5	58
S.19/32	19/32	12	22,8	21,4	36	12,0	60
S.5/8	5/8	12	21,6	22,6	36	12,0	65
S.21/32	21/32	12	23,1	24,1	36	13,0	65
S.11/16	11/16	12	22,6	24,6	36	13,0	71
S.3/4	3/4	12	25,0	27,0	36	14,0	68
S.25/32	25/32	12	25,9	27,9	36	14,0	72
S.13/16	13/16	12	24,6	28,6	38	16,0	96
S.7/8	7/8	12	26,4	30,4	38	16,5	99
S.15/16	15/16	12	28,7	32,7	38	16,5	132
S.31/32	31/32	12	27,7	34,1	38	16,5	131
S.1'	1	12	28,3	34,7	38	16,5	141
S.1'1/16	1 1/16	12	29,2	36,6	44	19,0	147
S.1'1/8	1 1/8	12	31,3	38,7	44	20,0	170
S.1'3/16	1 3/16	12	33,0	40,4	44	20,0	185
S.1'1/4	1 1/4	12	35,1	42,5	44	20,0	201

S.HLA - Nasadki 1/2" długie 6-kątne metryczne

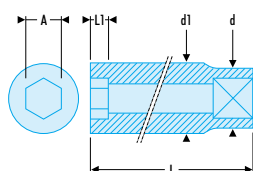

NF ISO 2725-1, NF ISO 1711-1, ISO 2725-1, ISO 1711-1, DIN 3124, ASME B107.5

- Profil OGV®: większa siła i bezpieczeństwo, ochrona nakrętek.
- Nasadki długie przeznaczone do gniazd lub długich gwintów.
- Wykończenie: chromowane błyszczące.

⇒	A [mm]	⌀ [mm]	d [mm]	d1 [mm]	L [mm]	L1 [mm]	ΔΔ [g]
S.12HLA	12	6	21	17,8	77	12	105
S.13HLA	13	6	21,8	19,0	77	12	115
S.14HLA	14	6	21,8	20,3	77	15	120
S.15HLA	15	6	21,8	21,5	77	15	125
S.16HLA	16	6	22,0	22,8	77	15	128
S.17HLA	17	6	23,0	24,0	77	15	140
S.18HLA	18	6	24,0	25,0	77	18	160
S.19HLA	19	6	25,0	26,5	77	18	160
S.21HLA	21	6	27,0	29,0	77	18	200
S.22HLA	22	6	28,0	30,0	77	21	215
S.23HLA	23	6	29,0	31,5	77	21	232
S.24HLA	24	6	30,0	32,8	77	24	255
S.26HLA	26	6	32,0	35,0	77	24	280
S.27HLA	27	6	33,0	36,5	77	27	310
S.28HLA	28	6	34,0	37,8	77	27	330
S.29HLA	29	6	35,0	39,0	77	27	355
S.30HLA	30	6	36,0	40,0	77	30	355
S.32HLA	32	6	38,0	42,8	77	33	408

S.LA - Nasadki 1/2" długie 12-kątne metryczne

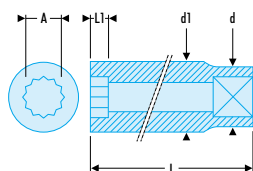

NF ISO 2725-1, NF ISO 1711-1, ISO 2725-1, ISO 1711-1, DIN 3124, ASME B107.5

- Profil OGV®: większa siła i bezpieczeństwo, ochrona nakrętek.
- Nasadki długie przeznaczone do gniazd lub długich gwintów.
- Wykończenie: chromowane błyszczące.

⇒	A [mm]	⌀ [mm]	d [mm]	d1 [mm]	L [mm]	L1 [mm]	ΔΔ [g]
S.12LA	12	12	21,0	17,8	77	12	105
S.13LA	13	12	21,8	19,0	77	12	115
S.14LA	14	12	21,8	20,3	77	15	125
S.15LA	15	12	21,8	21,5	77	15	125
S.16LA	16	12	22,0	22,8	77	15	135
S.17LA	17	12	23,0	24,0	77	15	145
S.18LA	18	12	24,0	25,0	77	18	160
S.19LA	19	12	25,0	26,5	77	18	180
S.21LA	21	12	27,0	29,0	77	18	210
S.22LA	22	12	28,0	30,0	77	21	215
S.23LA	23	12	29,0	31,5	77	21	240
S.24LA	24	12	30,0	32,8	77	24	255
S.26LA	26	12	32,0	35,0	77	24	280
S.27LA	27	12	33,0	36,5	77	27	315
S.28LA	28	12	34,0	37,8	77	27	340
S.29LA	29	12	35,0	39,0	77	27	365
S.30LA	30	12	36,0	40,0	77	30	365
S.32LA	32	12	36,0	42,8	77	33	415



■ S.LA - Nasadki 1/2" długie 12-kątne calowe

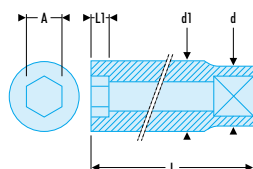

ASME B107.1

- Profil OGV®: większa siła i bezpieczeństwo, ochrona nakrętek.
- Nasadki długie przeznaczone do gniazd lub długich gwintów.
- Wykończenie: chromowane błyszczące.

⇒	A ["]	⌀ [mm]	d [mm]	d1 [mm]	L [mm]	L1 [mm]	ΔΔ [g]
S.1/2LA	1/2	12	22,3	19,0	82,2	8,1	135
S.9/16LA	9/16	12	22,3	20,6	82,2	9,6	138
S.5/8LA	5/8	12	22,3	22,3	82,2	10,9	150
S.11/16LA	11/16	12	24,4	24,4	82,2	10,9	160
S.3/4LA	3/4	12	26,9	26,9	82,2	12,4	165
S.13/16LA	13/16	12	28,7	28,7	82,2	12,9	175
S.7/8LA	7/8	12	30,2	30,2	82,2	14,0	200
S.15/16LA	15/16	12	31,7	31,7	82,2	15,0	225
S.1"LA	1	12	33,3	33,3	82,2	15,2	255
S.1"1/16LA	1 1/16	12	36,5	36,5	82,2	16,0	320
S.1"1/8LA	1 1/8	12	38,1	38,1	82,2	16,7	350
S.1"1/4LA	1 1/4	12	42,9	42,9	82,2	16,7	430

Nasadki 1/2" Torx®

■ STX - Nasadki 1/2" Torx®

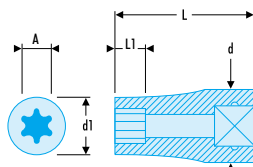

- Do śrub trzpieniowych Torx®.
- Wykończenie: chromowane błyszczące.
- Dostępne w zestawie na stojaku metalowym: Symbol STX.40 (E12 --> E20) i symbol RSX.J6 (E6 --> E16).

⇒	A [mm]	Torx [Nr]	d [mm]	d1 [mm]	L [mm]	L1 [mm]	ΔΔ [g]
STX.12	10,95	E12	21	15,0	37	8,0	47
STX.14	12,67	E14	21	16,3	37	8,8	47
STX.16	14,70	E16	22	18,8	37	9,6	57
STX.18	16,38	E18	22	20,4	37	11,1	57
STX.20	18,16	E20	22	22,9	37	12,7	63
STX.24	21,84	E24	22	26,5	37	16,1	97

Nasadki trzpieniowe 1/2"

■ STM - Nasadki trzpieniowe 1/2" do śrub 6-kątnych metrycznych

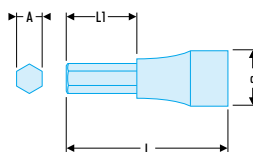

- Seria o długości standardowej.
- Dla śruby z łbem sześciokątnym
- Uchwyt zamocowany na stałe.
- Wykończenie: chromowane błyszczące z końcówką fosforowaną.
- Dostępne w zestawie w kasecie (symbol STM.J9).

⇒	A [mm]	d [mm]	L [mm]	L1 [mm]	ΔΔ [g]
STM.4	4	22,8	60	24	59
STM.5	5	22,8	60	24	60
STM.6	6	22,8	60	24	62
STM.7	7	22,8	60	24	64
STM.8	8	22,8	60	24	65
STM.9	9	22,8	60	24	70
STM.10	10	22,8	60	24	80
STM.12	12	23,1	60	24	102
STM.14	14	23,1	60	24	127
STM.17	17	23,4	60	24	152
STM.19	19	23,4	60	24	162

ST - Nasadki trzpieniowe 1/2" do śrub 6-kątnych calowych



- Seria o długości standardowej.
- Dla śruby z łbem sześciokątnym
- Uchwyt zamocowany na stałe.
- Wykończenie: chromowane błyszczące z końcówką fosforowaną.

⇒	A ["]	d [mm]	Końcówki	L [mm]	L1 [mm]	ΔΔ [g]
ST.1/4	1/4	23	EH.201/4	54	17	67
ST.5/16	5/16	23	EH.205/16	54	17	67
ST.3/8	3/8	23	EH.203/8	54	17	74
ST.7/16	7/16	23	ENH.307/16	70	31	110
ST.1/2	1/2	23	ENH.301/2	70	31	117
ST.9/16	9/16	23	ENH.309/16	70	31	125
ST.5/8	5/8	23	ENH.305/8	70	31	143
ST.3/4	3/4	23	ENH.303/4	70	31	165

SHP.LA - Nasadki trzpieniowe 1/2" długie do śrub z gniazdem 6-kątnym, metryczne

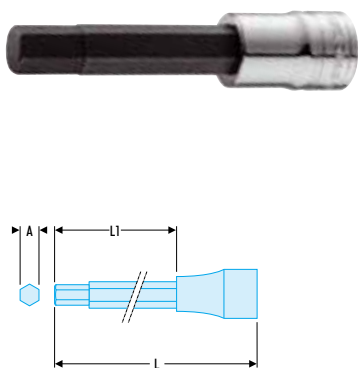

- Seria długa i ekstra-długa
- Dla śruby z łbem sześciokątnym
- Uchwyt zamocowany na stałe.
- Wykończenie: chromowane błyszczące z końcówką fosforowaną.

⇒	A [mm]	L [mm]	L1 [mm]	ΔΔ [g]
SHP.6LA	6	100	64	77
SHP.7LA	7	100	64	78
SHP.8LA	8	100	64	79
SHP.10LA	10	140	104	132
SHP.12LA	12	100	64	144
SHP.5ELA	5	180	144	112
SHP.6EL1A	6	140	104	93
SHP.6EL2A	6	220	184	127

SXM - Nasadki trzpieniowe 1/2" do wkrętów Torx®



- Seria o długości standardowej.
- Do wkrętów z gniazdem Torx®.
- Uchwyt zamocowany na stałe.
- Wykończenie: chromowane błyszczące z końcówką fosforowaną.
- Dostępne również w zestawie w kasecie (symbol AMEX.3).

⇒	A [mm]	Torx [Nnr]	d [mm]	L [mm]	L1 [mm]	ΔΔ [g]
SXM.20	3,84	T20	22,8	60	24	58
SXM.25	4,40	T25	22,8	60	24	58
SXM.27	4,96	T27	22,8	60	24	59
SXM.30	5,49	T30	22,8	60	24	59
SXM.40	6,60	T40	22,8	60	24	62
SXM.45	7,77	T45	22,8	60	24	63
SXM.50	8,79	T50	22,8	60	24	74
SXM.55	11,17	T55	22,8	60	24	96
SXM.60	13,17	T60	23,1	60	24	117

SX.LA - Nasadki trzpieniowe 1/2" z końcówką długą do wkrętów Torx®

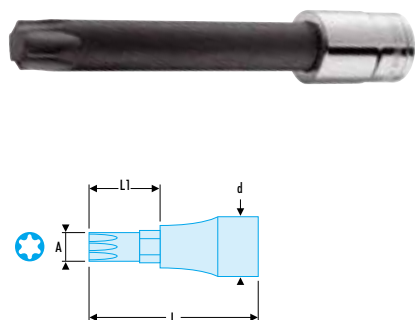

- Seria długa
- Do wkrętów z gniazdem Torx®.
- Uchwyt zamocowany na stałe.
- Wykończenie: chromowane błyszczące z końcówką fosforowaną.

⇒	A [mm]	Torx [Nnr]	d [mm]	L [mm]	L1 [mm]	ΔΔ [g]
SX.40LA	6,60	T40	22,8	120	84	95
SX.45LA	7,77	T45	22,8	120	84	95
SX.55LA	11,17	T55	22,8	140	104	220
SX.70LA	15,49	T70	23,1	140	104	280



▣ D.B - Nasadki trzpieniowe z 6-rowkami

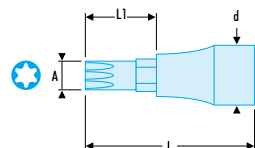

- Specjalne do odkręcania śrub głowic.
- Seria o długości standardowej.
- Do wkrętów z gniazdem rowkowanym.
- Uchwyt zamocowany na stałe.
- Wykończenie: chromowane błyszczące z końcówką fosforanowaną.

➤	A [mm]	d [mm]	L1 [mm]	ΔΔ [g]
D.34B7	7	7	15	60
D.34B7L	7	7	63	100
D.34B9L	9	9	63	100
D.34B10	10	10	15	60
D.34B12L	12	12	63	100
D.34B14L	14	14	63	100
D.34B16L	16	16	63	100

▣ SV.B - Nakrętki trzpieniowe 1/2" o wielu zębach XZN®

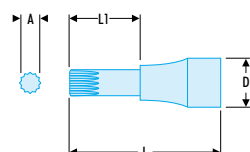

- Seria o długości standardowej.
- Do wkrętów z gniazdem XZN®.
- Uchwyt zamocowany na stałe.
- Wykończenie: chromowane błyszczące z końcówką fosforanowaną.

➤	A [mm]	d [mm]	L [mm]	L1 [mm]	ΔΔ [g]
SV.6B	M6	22,8	60	24	60
SV.8B	M8	22,8	60	24	60
SV.10B	M10	22,8	60	24	70
SV.12B	M12	22,8	60	24	80
SV.14B	M14	22,8	60	24	100
SV.16B	M16	23,1	60	24	110

▣ SV.LB - Nakrętki trzpieniowe 1/2" z końcówką długą i ekstra-długą o wielu zębach XZN®

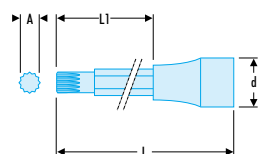

- Seria długa i ekstra-długa
- Do wkrętów z gniazdem XZN®.
- Uchwyt zamocowany na stałe.
- Wykończenie: chromowane błyszczące z końcówką fosforanowaną.

➤	A [mm]	d [mm]	L [mm]	L1 [mm]	ΔΔ [g]
SV.6LB	M6	22,8	100	64	80
SV.8LB	M8	22,8	100	64	80
SV.10LB	M10	22,8	100	64	90
SV.10ELB	M10	22,8	120	120	110
SV.12LB	M12	22,8	100	64	120
SV.12ELB	M12	22,8	140	104	150
SV.14LB	M14	22,8	100	64	150

PRZYGOTUJ WŁASNY ZESTAW NASADEK - KOŃCÓWEK

Końcówki do przykręcania



- Seria 2 \square 5/16"
- Seria 3 \square 1/2"

➤ Patrz rozdział 7

Nasadka \square 1/2" z uchwytem do końcówek 5/16"



▣ **S.236**
 \square 5/16"
7,94 mm













▣ **S.237**
 \square 1/2"
12,70 mm

➤ Patrz str. 296

ZESTAWY MULTI 1/4" + 1/2"

ZESTAWY NASADEK 1/4" + 1/2" W KASETACH

		RS.100	RSL.100	RS.360
   1/4" + 1/2"		R.161 + S.161	RL.161 + SL.161	R.360 + SL.161
		STANDARD	STANDARD	STANDARD
 1/4"	R.5,5	•	•	•
	R.6	•	•	•
	R.7	•	•	•
	R.8	•	•	•
	R.9	•	•	•
	R.10	•	•	•
	R.11	•	•	•
 1/2"	R.12	•	•	•
	R.13	•	•	•
	S.10	•	•	•
	S.11	•	•	•
	S.12	•	•	•
	S.13	•	•	•
	S.14	•	•	•
   	S.15	•	•	•
	S.17	•	•	•
	S.19	•	•	•
	S.21	•	•	•
	S.24	•	•	•
	S.27	•	•	•
	R.210	•	•	•
R.240A	•	•	•	
R.120A	•	•	•	
S.210	•	•	•	
S.240A	•	•	•	
 		BP.112 PL.404		
		389 x 164 x 66 mm		
		2,630 kg	2,590 kg	2,640 kg

RS.100 ▼







RSL.100 ▼



RS.360 ▼



ZESTAW NASADEK 1/4" + 1/2" NA SZYNIE METALOWEJ

		RSX.J6
  1/2" + 1/4"		STANDARD
Nasadki 	E.6	1/4"
	E.8	1/4"
	E.10	1/4"
	E.12	1/2"
	E.14	1/2"
	E.16	1/2"
Stojak 		CKS.98 0,205 kg

RSX.J6 ▼



ZESTAWY MULTI

1/4" + 1/2"

Typ nasadki		RS.440E	RS.430E	RSX.427P	RSX.19A	
Standard		R.161 + S.161	R.151 + S.151	R.161 + S.161	-	
1/4" + 1/2"		Standard	Standard	Standard	Standard	
1/4"	R.5	•	•			
	R.5.5	•	•			
	R.6	•	•			
	R.7	•	•			
	R.8	•	•			
	R.9	•	•			
	R.10	•	•			
	R.11	•	•			
	R.12	•	•			
	R.13	•	•			
	R.14	•	•			
	1/2"	SH.10	•	•		
		SH.11	•	•		
		SH.12	•	•		
SH.13		•	•			
SH.14		•	•			
SH.15		•	•			
SH.16		•	•			
SH.17		•	•			
SH.18		•	•			
SH.19		•	•			
SH.21		•	•			
SH.22		•	•			
SH.24		•	•			
SH.27		•	•			
SH.30	•	•				
SH.32	•	•				
EP	1	•				
	2	•				
	3	•				
ED	1	•				
	2	•				
	3	•				
ES	4,5					
	6,5					
	8					
	10					
EH	4	•				
	5	•				
	6	•				
	7	•				
	8	•				
EXR	10	•			•	
	15	•			•	
	20	•			•	
	25	•			•	
	27	•			•	
	30	•			•	
	40	•			•	
STX: nasadka Torx® 1/2"	STX.12			•	•	
	STX.14			•	•	
	STX.16			•	•	
	STX.18			•	•	
	STX.20			•	•	
SKM: nasadka do wkrętek 1/2" do wkrętów Tor®	27			•	•	
	30			•	•	
	40			•	•	
	45			•	•	
	50			•	•	
RTX: nasadka Torx® 1/4"	RTX.4			•	•	
	RTX.5			•	•	
	RTX.6			•	•	
	RTX.7			•	•	
	RTX.10			•	•	
Końcówki Torx®	8			•	•	
	10			•	•	
	15			•	•	
	20			•	•	
	25			•	•	
	27			•	•	
	40			•	•	
	45			•	•	
	50			•	•	
55			•	•		
R.209 R.210 R.240A R.120A R.235 R.236A S.210S S.210 S.215 S.240A S.236 AMZ.H	R.209	•				
	R.210	•	•			
	R.240A	•				
	R.120A					
	R.235	•		•	•	
	R.236A		•			
	S.210S	•				
	S.210		•			
	S.215		•			
	S.240A		•			
	S.236		•			
AMZ.H		•				
PL 714 BP.109		PL 112A BP.109	PL 220B BP.112	PL 393A BP.102		
478 x 234 x 72 mm			389 x 164 x 66 mm	204 x 122 x 52 mm		
3,92 kg			2,20 kg	0,62 kg		

RS.440E



RS.430E

























RSX.427P



RSX.19A



ZESTAWY MULTI Z ZABIERAKAMI KWADRATOWYMI 1/2" + 3/4"

   1/2" + 3/4"		SK.453N K.151B + S.151 STANDARD	SK.452N K.151B + S.151 STANDARD	SK.452U K.151B + S.152 STANDARD
 3/4"	K.22HB	•	•	
	K.24HB	•	•	
	K.27HB	•	•	
	K.30HB	•	•	
	K.32HB	•	•	
	K.34HB	•	•	
	K.36HB	•	•	
	K.41HB	•	•	
	K.46HB	•	•	
	K.50HB	•	•	
 1/2"	SH.8	•	•	
	SH.9	•	•	
	SH.10	•	•	
	SH.11	•	•	
	SH.12	•	•	
	SH.13	•	•	
	SH.14	•	•	
	SH.15	•	•	
	SH.16	•	•	
	SH.17	•	•	
	SH.18	•	•	
	SH.19	•	•	
	SH.21	•	•	
	SH.22	•	•	
	SH.23	•	•	
	SH.24	•	•	
SH.26	•	•		
SH.27	•	•		
SH.28	•	•		
SH.29	•	•		
SH.30	•	•		
SH.32	•	•		
 3/4"	K.1"1/16			•
	K.1"1/2			•
	K.1"1/4			•
	K.1"1/8			•
	K.1"13/16			•
	K.1"3/5			•
	K.1"5/8			•
	K.1"7/16			•
	K.2"			•
				•
 1/2"	S.1"			•
	S.1/2			•
	S.11/16			•
	S.1"1/16			•
	S.1"1/4			•
	S.1"1/8			•
	S.13/16			•
	S.1"3/16			•
	S.15/16			•
	S.19/32			•
	S.21/32			•
	S.25/32			•
	S.3/4			•
	S.3/8			•
	S.31/32			•
	S.5/8			•
	S.7/16			•
	S.7/8			•
	S.9/16			•
              	K.120B	•	•	•
	K.210B	•	•	•
	K.215B	•	•	•
	S.210S			•
	S.210	•	•	•
	S.215	•	•	•
	S.240A	•	•	•
	S.236	•	•	•
	S.110	•	•	•
	S.120A	•	•	•
		PL.21 BT.6A		PL.22 BT.6A
		468 x 190 x 160 mm		
		17,20 kg		16,2 kg

SK.453N



SK.452N



SK.452U



ZESTAWY NASADEK 3/4"

WYMIARY METRYCZNE

**FACOM JEST PRZY TOBIE
PODCZAS KONSERWACJI
MASZYN CIĘŻKICH!**

		K.411	K.441A	K.442E	K.437E	K.436E	SK.453N	SK.452N
		K.152	K.151B	K.151B	K.151B	K.151B	K.151B + S.151	K.151B + S.151
		6	6	12	6	12	6	6
		K.HB	K.HB	K.B	K.HB	K.B	K.HB	S.H
		6	6	12	6	12	6	6
		K.HB	K.HB	K.B	K.HB	K.B	K.HB	S.H
		6	6	12	6	12	6	6
		K.HB	K.HB	K.B	K.HB	K.B	K.HB	S.H
mm	8							
	9							
	10							
	11							
	12							
	13							
	14							
	15							
	16							
	17							
	18							
	19	•	•	•	•	•		
	21	•	•	•	•	•	3/4"	K.3/4"
	22	•	•	•	•	•	•	•
	23	•	•	•	•	•	•	•
	24	•	•	•	•	•	•	•
	26							
	27	•	•	•	•	•	•	•
	28							
29								
30	•	•	•	•	•	•	•	
32	•	•	•	•	•	•	•	
34	•	•	•	•	•	•	•	
36	•	•	•	•	•	•	•	
38	•	•	•	•	•	•	•	
41	•	•	•	•	•	•	•	
42								
46	•	•	•	•	•	•	•	
50	•	•	•	•	•	•	•	
54	•	•	•	•	•	•	•	
55	•	•	•	•	•	•	•	
K.210B K.215B K.120B K.240A K.140A K.125A	S.210						•	•
	S.215						•	•
	S.120A						•	•
	S.240A						•	•
	S.110						•	•
PL.438	C.K422CA + 2 x C.K422EA				PL.87A		P.21	
	BT.103G	BT.6A	BT.103G	BT.6A				
643 x 230 x 111 mm	468 x 190 x 160 mm	643 x 230 x 111 mm	468 x 190 x 160 mm					
15,20 kg	17,00 kg	15,50 kg	17,20 kg					

K.411



**K.437E
K.436E**



**K.441A
K.442E**



**SK.453N
SK.452N**

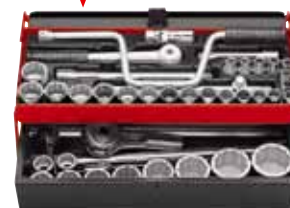

ZESTAWY NASADEK 3/4"

WYMIARY METRYCZNE



KONSERWACJA MASZYN ROLNICZYCH



KONSERWACJA MASZYN PRZEMYSŁOWYCH



NAPRAWY SAMOCHODÓW CIĘŻAROWYCH

K.420N / K.421N

















K.432E / K.433E



MOD.K2



















	K.421N	K.420N	K.433E	K.432E	MOD.K2	MOD.K1	K.415E	K.405E
	K.151B	K.151B	K.151B	K.151B	K.152	K.151B	K.151B	-
	K.HB	K.B	K.HB	K.B	K.HB	K.HB	K.LA	K.LA
								
								
mm								
22	•	•					•	•
23							•	•
24	•	•					•	•
26							•	•
27	•	•					•	•
29							•	•
30	•		•	•			•	•
32	•	•	•	•			•	•
33							•	•
34							•	•
36	•	•	•	•	•		•	•
38							•	•
41	•	•					•	•
42							•	•
46	•	•	•	•	•		•	•
50	•	•	•	•	•		•	•
54							•	•
55							•	•
	K.210B		•	•	•	•	•	
	K.215B	•	•	•	•	•	•	
	K.120B	•	•	•		•	•	
	K.240A				•			
	K.140A							
	K.125A							
	K.230B					•		
	PL.42 BT.103G		PL.40 BT.103G		PL.43	PL.60A	PL.43 BT.103G	PL.60A BT.111
	643 x 230 x 111 mm		643 x 230 x 111 mm				643 x 230 x 111 mm	396 x 224 x 82 mm
	12,90 kg	12,90 kg	16,30 kg	16,30 kg	7,46 kg	8,29 kg	16,27 kg	9,30 kg



ZESTAWY NASADEK 3/4"

WYMIARY CALOWE

   3/4" 19,05mm		K.442U		SK.452U	
		K.151B	K.B	K.151B + S.151	
 mm	3/8				•
	7/16				•
	1/2				•
	9/16				•
	19/32				•
	5/8				•
	21/32				•
	11/16				•
	3/4				•
	25/32				•
	13/16				•
	3/4	•			•
	7/8	•			•
	15/16	•			•
	31/32	•			•
	1	•		3/4"	•
	1"1/16	•		•	•
	1"1/8	•		•	•
	1"1/4	•		•	•
	1"5/16	•			1/2"
	1"3/8	•		•	
	1"7/16	•		•	
	1"1/2	•		•	
	1"5/8	•		•	
1"11/16	•				
1"3/4	•				
1"13/16	•		•		
1"7/8	•				
2"	•		•		
2"1/8	•				
2"3/16	•				
2"1/4	•				
 K.210B	•		•		
 K.215B	•		•		
 K.120B	•		•		
 K.240A	•				
 K.140A	•				
 K.125A	•				
 S.210				•	
 S.215				•	
 S.120A				•	
 S.240A				•	
 S.110				•	
	-		PL.22		
	BT.6A		BT.6A		
	468 x 190 x 160 mm		468 x 190 x 160 mm		
	22,1 kg		16,2 kg		



K.442U



SK.452U



Grzechotki 3/4"

K.152

GRZECHOTKA 3/4" KOMPAKTOWA I PRECYZYJNA

**GRZECHOTKA 25%
BARDZIEJ KOMPAKTOWA,
ROZWIĄZANIE
PROBLEMÓW Z
DOSTĘPEM!**

KOMFORT UŻYTKOWANIA

- Ergonomiczna rękojeść do chwytu 2 rękami: umożliwia przykładanie dużych sił.

PARAMETRY

- Precyzja: mechanizm 72-zębny, skok zęba co 5°.
- Moc i wytrzymałość: 17 zębów używanych podczas dokręcania.
- Grzechotka jednoelementowa: lżejsza, poręczniejsza.
- Trudny dostęp: głowica 25% bardziej kompaktowa niż w przypadku grzechotek tradycyjnych.

BEZPIECZEŃSTWO

- Blokowanie grzechotki/nasadki/ akcesoriów za pomocą zatrzasku.



Grzechotka 3/4" „compact”

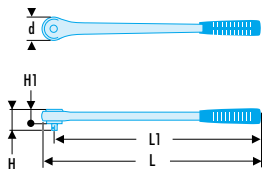

NF ISO 3315, ISO 3315, DIN 3122, ASME B107.10

- Grzechotka jednoczęściowa, o zwiększonej lekkości i poręczności.
- Zwarta głowka.
- Rękojeść ergonomiczna umożliwiająca chwyt 2 rękami.
- Zmniejszony skok zęba: 5°.
- Mechanizm z 72 zębami.
- Blokowanie nasadki za pomocą zatrzasku.
- Wykończenie: chromowane satynowane.

	d [mm]	H [mm]	H1 [mm]	L [mm]	L1 [mm]	ΔΔ [kg]
K.152	62	56,5	32	505	474	1,67



Grzechotka 3/4" z rękojeścią demontowalną

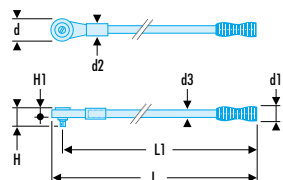

NF ISO 3315, ISO 3315, DIN 3122, ASME B107.10

- Zmniejszony skok zęba: 5°.
- Mechanizm z 72 zębami.
- Blokowanie nasadki za pomocą zatrzasku.
- Wykończenie: chromowane satynowane.

⇒	d [mm]	d1 [mm]	d2 [mm]	d3 [mm]	H [mm]	H1 [mm]	L [mm]	L1 [mm]	ΔΔ [kg]
K.154B	69	40	30	20	61	37	548	514	2,40

Grzechotka 3/4" bez rękojeści

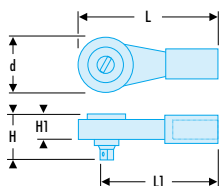

NF ISO 3315, ISO 3315, DIN 3122, ASME B107.10

- Zmniejszony skok zęba: 5°.
- Mechanizm z 72 zębami.
- Stosowana z trzpieniem K.125 lub K.126 i rękojeścią K.154AM.
- Blokowanie nasadki za pomocą zatrzasku.
- Wykończenie: chromowane.
- Rękojeść z uchwytem plastikowym do grzechotki K.151B.

⇒	d [mm]	H [mm]	H1 [mm]	L [mm]	L1 [mm]	ΔΔ [kg]
K.151B	68	60,8	36,6	170	136	1,20

Grzechotka 3/4" „budowlana”

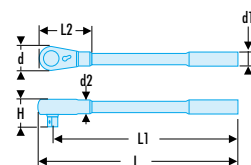





NF ISO 3315, ISO 3315, DIN 3122, ASME B107.10

- Dostosowana do prac na zewnątrz:
 - Mechanizm zabezpieczony przed zanieczyszczeniami.
 - Wbudowany przełącznik.
 - Skok zęba 9°.
 - Mechanizm z 40 zębami.
 - Rękojeść demontowana.
- Blokowanie nasadki za pomocą zatrzasku.
- Wykończenie: chromowane matowe.

⇒	d [mm]	d1 [mm]	d2 [mm]	H [mm]	L [mm]	L1 [mm]	L2 [mm]	ΔΔ [kg]
K.149	65,5	25	32	62	510	475	151	2,85

KONSERWACJA GRZECHOTEK 3/4"

• Konserwacja grzechotki jest bardzo prostą operacją: Zwykłe czyszczenie i okresowa wymiana elementów zużywających się umożliwia zachowanie grzechotki zawsze w doskonałym stanie i dostępnej.

	K.150	K.150A	K.151	K.151A	K.151B	K.152	K.154A	K.154B	K.149
Nakładki									
 K.152C						•			
M.151C			•						
K.151BC				•	•			•	
Zestaw części zamiennych									
 K.151RN			•	•	•		•	•	
K.152RN						•			
K.150RN	•	•							
Zabierak									
 K.152R						•			
K.150R	•								
K.150AR		•							
K.151AR				•	•			•	
Kompletny zestaw części									
 K.149RN									•

Akcesoria 3/4"

K.154AM Rękojeść do grzechotki 3/4"



- Rękojeść przeznaczona do grzechotek 3/4" K.154B i K.151B.
- Plastikowy uchwyt zapewniający większą wygodę.

K.A - Wrzeciono do grzechotki 3/4"

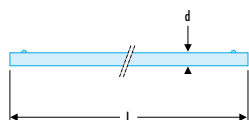

- Wykorzystywane jako uchwyty przedłużające do grzechotek K.151B oraz do uchwytów K.140A i K.200E.
- Wykończenie: chromowane satynowane.

	d [mm]	L [mm]	ΔΔ [kg]
K.125A	20	425	1,04
K.126A	20	500	1,22

Rękojeść przesuwna 3/4"

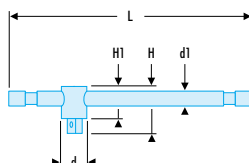

NF ISO 3315, ISO 3315, DIN 3122, ASME B107.10

- Przesuwana główka z zatrząskiem kulkowym.
- Położenie w kształcie T lub L.
- Wykończenie: chromowane satynowane.

	d [mm]	d1 [mm]	H [mm]	H1 [mm]	L [mm]	ΔΔ [kg]
K.120B	36	20	62	37	425	1,30

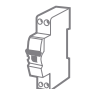

☐ Rękojeść odgięta 3/4"

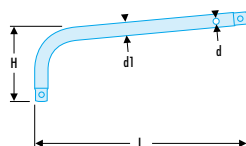

NF ISO 3315, ISO 3315, DIN 3122

- Na obu końcówkach można zamontować nasadkę 3/4":
- Strona odgięta: silna blokada.
- Strona długa: trudny dostęp lub szybkie zbliżanie.
- Wykończenie: chromowane satynowane.

☞	d [mm]	d1 [mm]	H [mm]	L [mm]	ΔΔ [kg]
K.130A	8	25	85	540	2,30

☐ Zabierak kwadratowy stały 3/4"

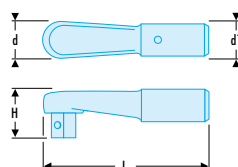

- Używana z trzpieniem K.125 lub K.126.
- Do odkręcania z dużą siłą bez ryzyka uszkodzenia grzechotki.
- Wykończenie: chromowane satynowane.

☞	d [mm]	d1 [mm]	H [mm]	L [mm]	ΔΔ [g]
K.200E	35	30	40	152	630

☐ Rękojeść przegubowa 3/4"

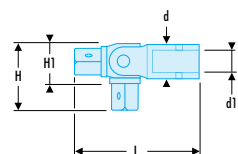

NF ISO 3315, ISO 3315, DIN 3122

- Używana z trzpieniem K.125 lub K.126.
- Umożliwia manewrowanie nakrętkami we wszystkich pozycjach kątowych w zakresie 180°.
- Przegub 180°.
- Blokowanie przegubu w dowolnej pozycji za pomocą sprężyny.
- Wykończenie: chromowane satynowane.

☞	d [mm]	d1 [mm]	H [mm]	H1 [mm]	L [mm]	ΔΔ [g]
K.140A	40	20	70	46	125	760

☐ K.B - Przedłużacze 3/4"

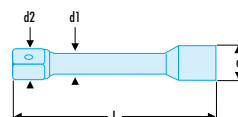

NF ISO 3316, ISO 3316, DIN 3123, ASME B107.10

- Wykończenie: chromowane satynowane.

☞	d [mm]	d1 [mm]	d2 [mm]	L [mm]	ΔΔ [kg]
K.208B	36	25	25	100	0,410
K.210B	36	20	25	200	0,620
K.215B	36	20	25	400	1,130

Przegub uniwersalny 3/4"

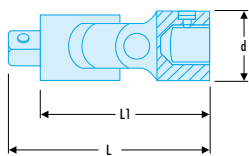

NF ISO 3316, ISO 3316, DIN 3123, ASME B107.10

- Przegub hamowany sprężyną.
- Pozwala na znaczną oszczędność czasu.
- Wykończenie: chromowane satynowane.

Symbol	d [mm]	L [mm]	L1 [mm]	ΔΔ [g]
K.240A	40	105	82	550

Reduktor z 3/4" do 1/2"

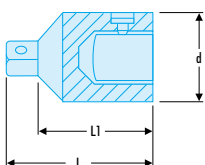

NF ISO 3316, ISO 3316, DIN 3123, ASME B107.10

- Umożliwia stosowanie nasadek i akcesoriów 1/2".
- Końcówka kwadratowa 1/2" wymienna (symbol K.230B1).
- Moment maksymalny: 512 Nm.
- Wykończenie: chromowane satynowane, zabierak fosforanowany.

Symbol	d [mm]	L [mm]	L1 [mm]	ΔΔ [g]
K.230B	36	58,5	43	250

K.230B1 Wymienny zabierak kwadratowy 1/2"



- Wymienny zabierak 1/2" do reduktora L 3/4" do L 1/2" (symbol K.230B).
- Wykończenie: chromowane satynowane.

Przełożenie 3/4" do 1"

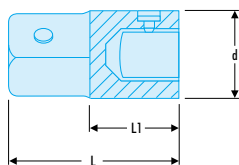

NF ISO 3316, ISO 3316, DIN 3123, ASME B107.10

- Umożliwia stosowanie nasadek i akcesoriów 1".
- Wykończenie: chromowane satynowane.

Symbol	d [mm]	L [mm]	L1 [mm]	ΔΔ [g]
K.232A	36	67	39	340

BŁOKOWANIE NASADEK I AKCESORIÓW 3/4" - 1"

BEZPIECZEŃSTWO I PROSTOTA!

- Zatrzask zabezpiecza przed wypadnięciem nasadki podczas użytkowania.
- Szybkie odblokowanie po naciśnięciu przycisku.
- Zgodność z klasycznymi narzędziami mocowanymi na kulkę.

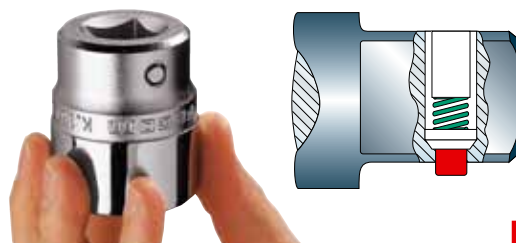

Nasadki 3/4"

▣ K.HB - Nasadki 3/4" 6-kątne metryczne

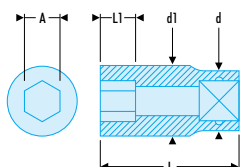

NF ISO 2725-1, NF ISO 1711-1, ISO 2725-1, ISO 1711-1, DIN 3124, ASME B107.5

- Profil OGV®: większa siła i bezpieczeństwo, ochrona nakrętek.
- Umożliwiają blokowanie akcesoriów wyposażonych w zatrzaski.
- Wyposażone w przycisk szybkiego odblokowywania.
- Wykończenie: chromowane satynowane.

➤	A [mm]	⌀ [mm]	d [mm]	d1 [mm]	L [mm]	L1 [mm]	ΔΔ [g]
K.19HB	19	6	36	30,1	51,0	14	207
K.21HB	21	6	36	32,0	51,0	14	208
K.22HB	22	6	36	33,4	51,0	14	221
K.23HB	23	6	36	36,0	52,5	14	244
K.24HB	24	6	36	36,0	52,5	16	237
K.26HB	26	6	36	38,9	52,5	16	231
K.27HB	27	6	36	39,7	52,5	18	232
K.28HB	28	6	36	41,0	52,5	18	239
K.29HB	29	6	36	42,0	52,5	18	245
K.30HB	30	6	36	43,2	59,0	20	282
K.32HB	32	6	36	45,9	59,0	22	301
K.33HB	33	6	36	48,1	59,0	22	330
K.34HB	34	6	36	48,4	59,0	24	322

➤	A [mm]	⌀ [mm]	d [mm]	d1 [mm]	L [mm]	L1 [mm]	ΔΔ [g]
K.35HB	35	6	36	50,1	59,0	24	344
K.36HB	36	6	36	51,0	59,0	24	347
K.38HB	38	6	40	54,3	66,9	27	478
K.40HB	40	6	40	56,0	66,9	27	493
K.41HB	41	6	40	57,3	66,9	27	504
K.42HB	42	6	40	59,5	66,9	27	552
K.43HB	43	6	40	60,7	66,9	27	560
K.44HB	44	6	40	61,9	66,9	28	587
K.46HB	46	6	40	63,5	75,0	30	641
K.50HB	50	6	40	68,5	75,0	33	725
K.54HB	54	6	45	74,0	75,0	36	880
K.55HB	55	6	45	74,7	75,0	36	875

▣ K.B - Nasadki 3/4" 12-kątne metryczne

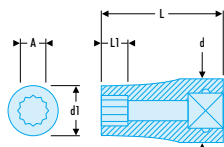

NF ISO 2725-1, NF ISO 1711-1, ISO 2725-1, ISO 1711-1, DIN 3124, ASME B107.5

- Profil OGV®: większa siła i bezpieczeństwo, ochrona nakrętek.
- Umożliwiają blokowanie akcesoriów wyposażonych w zatrzaski.
- Wyposażone w przycisk szybkiego odblokowywania.
- Wykończenie: chromowane satynowane.

➤	A [mm]	⌀ [mm]	d [mm]	d1 [mm]	L [mm]	L1 [mm]	ΔΔ [g]
K.19B	19	12	36	30,1	51,0	14	207
K.21B	21	12	36	32,0	51,0	14	208
K.22B	22	12	36	33,4	51,0	14	221
K.23B	23	12	36	36,0	52,5	14	244
K.24B	24	12	36	36,0	52,5	16	237
K.26B	26	12	36	38,9	52,5	16	231
K.27B	27	12	36	39,7	52,5	18	232
K.28B	28	12	36	41,0	52,5	18	239
K.29B	29	12	36	42,0	52,5	18	245
K.30B	30	12	36	43,2	59,0	20	282
K.32B	32	12	36	45,9	59,0	22	301
K.33B	33	12	36	48,1	59,0	22	330
K.34B	34	12	36	48,4	59,0	24	322
K.35B	35	12	36	50,1	59,0	24	344

➤	A [mm]	⌀ [mm]	d [mm]	d1 [mm]	L [mm]	L1 [mm]	ΔΔ [g]
K.36B	36	12	36	51,0	59,0	24	347
K.38B	38	12	40	54,3	66,9	27	478
K.40B	40	12	40	56,0	66,9	27	493
K.41B	41	12	40	57,3	66,9	27	504
K.42B	42	12	40	59,5	66,9	27	552
K.43B	43	21	40	60,7	66,9	28	301
K.44B	44	12	40	61,9	66,9	28	587
K.46B	46	12	40	63,5	75,0	30	641
K.50B	50	12	40	68,5	75,0	33	725
K.54B	54	12	45	74,0	75,0	36	880
K.55B	55	12	45	74,7	75,0	36	875

K.B - Nasadki 3/4" 12-kątne calowe

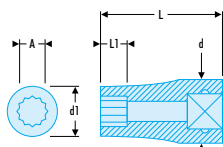

ASME B107.1

- Profil OGV®: większa siła i bezpieczeństwo, ochrona nakrętek.
- Umożliwiają blokowanie akcesoriów wyposażonych w zatrzaski.
- Wyposażone w przycisk szybkiego odblokowywania.
- Wykończenie: chromowane satynowane.

➤	A ["]	⊘ [mm]	d [mm]	d1 [mm]	L [mm]	L1 [mm]	ΔΔ [g]
K.3/4B	3/4	12	36	30,1	51,0	14	207
K.7/8B	3/4	12	36	33,6	51,0	14	220
K.15/16B	15/16	12	36	35,7	52,5	14	233
K.1"B	1"	12	36	38,0	52,5	14	250
K.1"1/16B	1 1/16"	12	36	39,7	52,5	18	232
K.1"1/8B	1 1/8"	12	36	41,6	52,5	18	241
K.1"3/16B	1 3/16"	12	36	43,2	59,0	20	280
K.1"1/4B	1 1/4"	12	36	45,9	59,0	22	304
K.1"5/16B	1 5/16"	12	36	48,1	59,0	22	326
K.1"3/8B	1 3/8"	12	36	50,1	59,0	24	343
K.1"7/16B	1 7/16"	12	36	51,0	59,0	24	339
K.1"1/2B	1 1/2"	12	40	54,3	66,9	27	478

➤	A ["]	⊘ [mm]	d [mm]	d1 [mm]	L [mm]	L1 [mm]	ΔΔ [g]
K.1"9/16B	1 9/16"	12	40	56,0	66,9	27	498
K.1"5/8B	1 5/8"	12	40	57,3	66,9	27	498
K.1"11/16B	1 11/16"	12	40	60,7	66,9	27	564
K.1"3/4B	1 3/4"	12	40	62,2	66,9	28	586
K.1"13/16B	1 13/16"	12	40	63,5	75,0	30	641
K.1"7/8B	1 7/8"	12	40	66,2	75,0	33	699
K.2"B	2"	12	40	68,5	75,0	33	698
K.2"1/8B	2 1/8"	12	45	74,0	75,0	36	880
K.2"3/16B	2 3/16"	12	45	74,7	75,0	36	855
K.2"1/4B	2 1/4"	12	45	77,1	75,0	36	913

K.LA - Nasadki 3/4" długie 6-kątne metryczne

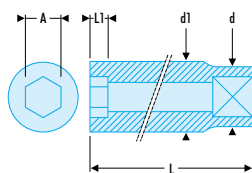

NF ISO 2725-1, NF ISO 1711-1, ISO 2725-1, ISO 1711-1, DIN 3124, ASME B107.5

- Profil OGV®: większa siła i bezpieczeństwo, ochrona nakrętek.
- Umożliwiają blokowanie akcesoriów wyposażonych w zatrzaski.
- Wyposażone w przycisk szybkiego odblokowywania.
- Wykończenie: chromowane satynowane.

➤	A [mm]	⊘ [mm]	d [mm]	d1 [mm]	L [mm]	L1 [mm]	ΔΔ [g]
K.19LA	19	6	36	30,1	90	18	339
K.21LA	21	6	36	32,0	90	18	367
K.22LA	22	6	36	33,4	90	21	391
K.23LA	23	6	38	36,0	90	21	461
K.24LA	24	6	38	36,0	90	24	400
K.26LA	26	6	36	38,9	90	24	474
K.27LA	27	6	38	39,7	90	27	480
K.29LA	29	6	40	42,0	90	27	505
K.30LA	30	6	40	43,2	90	30	530

➤	A [mm]	⊘ [mm]	d [mm]	d1 [mm]	L [mm]	L1 [mm]	ΔΔ [g]
K.32LA	32	6	40	45,9	90	33	540
K.33LA	33	6	45	48,1	90	33	600
K.34LA	34	6	45	48,4	90	33	656
K.35LA	35	6	45	50,1	90	33	707
K.36LA	36	6	45	51,0	90	36	672
K.38LA	38	6	45	54,3	90	36	772
K.41LA	41	6	45	57,3	90	40	778
K.42LA	42	6	45	59,5	90	40	863

KT.A - Nasadki trzpieniowe 3/4" do śrub 6-kątnych metrycznych

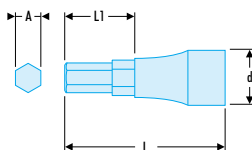

- Końcówki wymienne blokowane trzpieniem
- Wykończenie: chromowane z końcówką fosforanowaną.

➤	A [mm]	d [mm]	Końcówki	L [mm]	L1 [mm]	ΔΔ [g]
KT.14A	14	36	ET.1914	74,5	25	297
KT.17A	17	36	ET.1917	74,5	25	307
KT.19A	19	36	ET.1919	74,5	25	314
KT.22A	22	36	ET.1919	74,5	25	314



Zestawy nasadek 1" metrycznych

▣ M.431E Zestaw nasadek 1" 6-kątnych od 42 do 82 mm



- Zawiera:
 - Grzechotka: M.151.
 - Nasadki: M.50HA - M.54HA - M2'1/8HA - M.55HA - M.58HA - M.60HA - M.63HA - M.65HA - M.67HA - M.70HA - M.71HA - M.75HA - M.77HA - M.80HA - M.82HA - M46HA - M1'13/16HA.
 - Akcesoria: M.120A - M.210A - M.215A.
 - Skrzynka metalowa BT.101, wym. (dł. x gł. x wys.): 768 x 344 x 158 mm.
 - Wkładka PL.57.
- Masa: 46 kg.

▣ M.441E Zestaw nasadek 1" 6-kątnych od 58 do 100 mm



- Zawiera:
 - Grzechotka: M.151.
 - Nasadki: M.58HA - M.60HA - M.63HA - M.65HA - M.67HA - M.70HA - M.71HA - M.75HA - M.77HA - M.80HA - M.82HA - M.85HA - M.90HA - M.95HA - M.100HA.
 - Akcesoria: M.120A - M.210A - M.215A.
 - Skrzynka metalowa BT.101, wym. (dł. x gł. x wys.): 768 x 344 x 158 mm.
 - Wkładka PL.54.
- Masa: 64,20 kg.

▣ M.423E Zestaw nasadek 1" 6-kątnych od 41 do 80 mm



- Zawiera:
 - Grzechotka: M.151.
 - Nasadki: M.58HA - M.60HA - M.63HA - M.65HA - M.67HA - M.70HA - M.71HA - M.75HA - M.77HA - M.80HA - M.82HA - M.85HA - M.90HA - M.95HA - M.100HA.
 - Akcesoria: M.120A - M.210A - M.215A.
 - Skrzynka metalowa BT.104, wym. (dł. x gł. x wys.): 568 x 344 x 123 mm.
 - Wkładka PL.85.
- Masa: 29,70 kg.

Zestawy nasadek 1" calowych

▣ M.431U Zestaw nasadek 1" 6-kątnych od 1" 7/8 do 3" 3/8



- Zawiera:
 - Grzechotka: M.151.
 - Nasadki: M.1'7/8HA - M.2'1/2HA - M.2'1/4HA - M.2'3/16HA - M.2'3/4HA - M.2'3/8HA - M.2'5/8HA - M.2'HA - M.3'1/8HA - M.3'3/8HA - M.3'HA - M.54HA-M2'1/8HA.
 - Akcesoria: M.120A - M.210A - M.215A.
 - Skrzynka metalowa BT.101, wym. (dł. x gł. x wys.): 768 x 344 x 158 mm.
 - Wkładka PL.58.
- Masa: 29,70 kg.

Grzechotki i akcesoria 1"

Grzechotka 1" bez rękojści

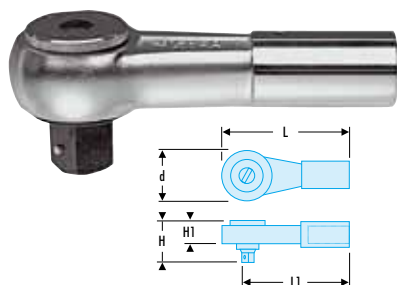

NF ISO 3315, ISO 3315, DIN 3122, ASME B107.10

- Skok zęba co 5°.
- Mechanizm z 72 zębami.
- Używana z trzpieniem M.125 lub M.126 lub z trzpieniem rękojści M.120.
- Wykończenie: chromowane satynowane.

🔧	d [mm]	H [mm]	H1 [mm]	L [mm]	L1 [mm]	ΔΔ [kg]
M.151	73	77	45	197	161	2,10

M.A - Wrzeciono do grzechotki 1" M.151

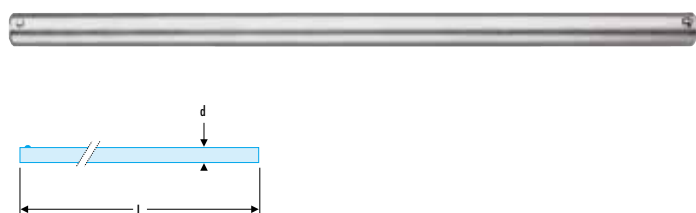

- Używane jako przedłużenie rękojści grzechotki M.151.
- Wykończenie: chromowane satynowane.

🔧	d [mm]	L [mm]	ΔΔ [kg]
M.125A	25	500	1,90
M.126A	25	700	2,70

Rękojść przesuwna 1"

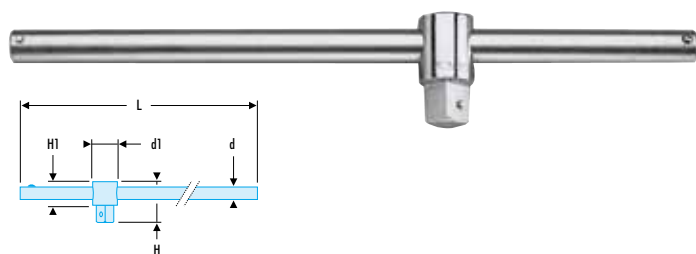

NF ISO 3315, ISO 3315, DIN 3122, ASME B107.10

- Mechanizm hamowania umieszczony w główce rękojści utrzymuje przesuwny trzpień w pozycji klucza w literę T lub L.
- Wyposażony w blokadę trzpieniem.
- Wykończenie: chromowane satynowane.

🔧	d [mm]	d1 [mm]	H [mm]	H1 [mm]	L [mm]	ΔΔ [kg]
M.120A	25	42	79	49,5	500	2,40

M.A - Przedłużacze 1"

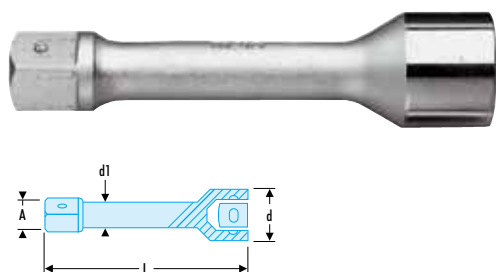

NF ISO 3315, ISO 3315, DIN 3122, ASME B107.10

- Wyposażone w odblokowanie bezpieczeństwa trzpieniem.
- Wykończenie: chromowane satynowane.

🔧	A [mm]	d [mm]	d1 [mm]	L [mm]	ΔΔ [kg]
M.210A	33	48	25	200	1,10
M.215A	33	48	25	415	2,00

M.230C Reduktor 1" do nasadek 3/4"

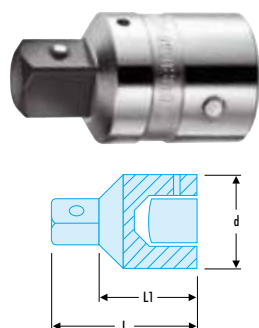

NF ISO 3316, ISO 3316, DIN 3123

- Użycie grzechotki/akcesoriów 1" z nasadkami 3/4".
 - Zabierak kwadratowy wymienny 3/4": M.230C1.
 - Wykończenie: chromowane satynowane, zabierak polerowany.
- Masa: 415 g.



▣ M.230C1 Wymienny zabierak kwadratowy 3/4"



- Moment maksymalny 1412 Nm.
 - Wymienny zabierak 3/4" do reduktora z 1" do 3/4" (symbol K.230M).
 - Wykończenie: polerowane.
- Masa: 111 g.

Nasadki 1"

▣ M.HA - Nasadki 1" 6-kątne metryczne

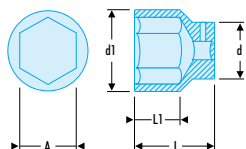

NF ISO 2725-1, NF ISO 1711-1, ISO 2725-1, ISO 1711-1, DIN 3124

- Zmniejszone wymiary dla zmniejszenia ciężaru.
- Umożliwiają blokowanie akcesoriów wyposażonych w zatrzaski.
- Wyposażone w przycisk odblokowywania.
- Wykończenie: chromowane satynowane.

№	A [mm]	⊙ [mm]	d [mm]	d1 [mm]	L [mm]	L1 [mm]	ΔΔ [kg]
M.41HA	41	6	51,3	56,9	74	25	0,685
M.46HA	46	6	51,3	64,4	76	30	0,852
M.50HA	50	6	51,3	69,4	80	33	0,968
M.54HA	54	6	56,3	74,4	84	31	1,262
M.55HA	55	6	56,3	75,4	84	36	1,262
M.58HA	58	6	56,3	79,6	85	35	1,354
M.60HA	60	6	56,3	82,4	87	39	1,432
M.63HA	63	6	58,3	85,4	92	35	1,545
M.65HA	65	6	58,3	88,4	92	42	1,652
M.67HA	67	6	58,3	90,4	92	39	1,687

№	A [mm]	⊙ [mm]	d [mm]	d1 [mm]	L [mm]	L1 [mm]	ΔΔ [kg]
M.70HA	70	6	56,3	95,0	96	45	1,921
M.71HA	71	6	56,3	96,0	96	45	1,904
M.75HA	75	6	63,3	101,0	100	48	2,261
M.77HA	77	6	63,3	108,0	100	51	2,751
M.80HA	80	6	63,3	108,0	106	52	2,800
M.82HA	82	6	63,3	110,8	110	52	2,880
M.85HA	85	6	71,3	114,0	110	52	3,225
M.90HA	90	6	71,3	121,0	110	56	3,555
M.95HA	95	6	71,3	127,0	110	56	3,800
M.100HA	100	6	71,3	133,0	115	56	4,225

▣ M.HA - Nasadki 1" 6-kątne calowe

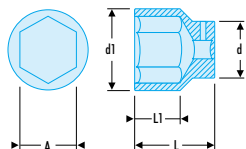

ASME B107.1

- Zmniejszone wymiary dla zmniejszenia ciężaru.
- Umożliwiają blokowanie akcesoriów wyposażonych w zatrzaski.
- Wyposażone w przycisk odblokowywania.
- Wykończenie: chromowane satynowane.

№	A ["]	⊙ [mm]	d [mm]	d1 [mm]	L [mm]	L1 [mm]	ΔΔ [kg]
M.1"13/16HA	1"13/16	6	51,3	64,4	76	30	0,852
M.1"7/8HA	1"7/8	6	51,3	66,4	80	29	0,929
M.2"HA	2"	6	51,3	70,4	80	31	1,000
M.2"1/8HA	2"1/8	6	56,3	74,4	84	31	1,262
M.2"3/16HA	2"3/16	6	56,3	75,4	84	35	1,253
M.2"1/4HA	2"1/4	6	56,3	78,5	84	35	1,368
M.2"3/8HA	2"3/8	6	56,3	82,4	87	39	1,439

№	A ["]	⊙ [mm]	d [mm]	d1 [mm]	L [mm]	L1 [mm]	ΔΔ [kg]
M.2"1/2HA	2"1/2	6	58,3	86,4	92	35	1,570
M.2"5/8HA	2"5/8	6	58,3	90,4	92	39	1,704
M.2"3/4HA	2"3/4	6	94,4	58,3	96	45	1,904
M.3"HA	3"	6	65,3	103,4	100	51	2,347
M.3"1/8HA	3"1/8	6	65,3	107,4	106	51	2,770
M.3"3/8HA	3"3/8	6	73,3	113,4	110	56	3,225

▣ Nasadki 1" 12-kątne

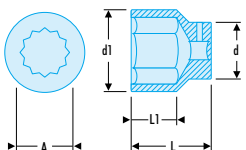

ASME B107.1

- Zmniejszone wymiary dla zmniejszenia ciężaru.
- Umożliwiają blokowanie akcesoriów wyposażonych w zatrzaski.
- Wyposażone w przycisk odblokowywania.
- Wykończenie: chromowane.

№	A [mm]	⊙ [mm]	d [mm]	d1 [mm]	L [mm]	L1 [mm]	ΔΔ [kg]
M.65B	65	12	58,3	85,4	92	42	1,652

NASADKI I AKCESORIA UDAROWE

OPRACOWANE DO PRACY NA NARZĘDZIACH UDAROWYCH!

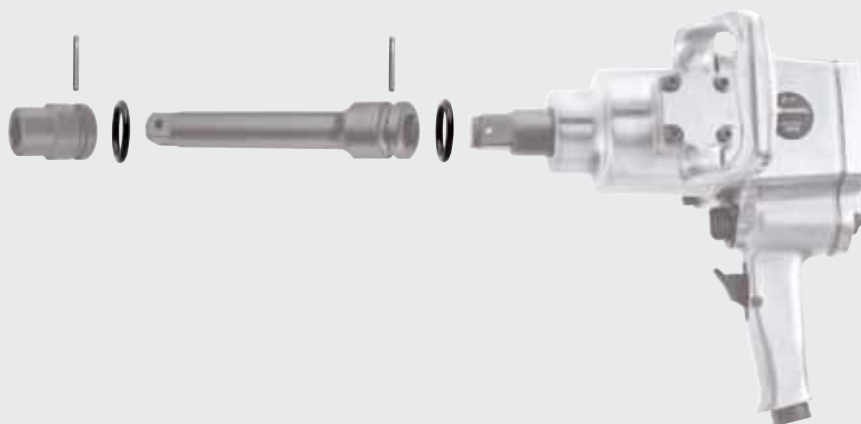

PARAMETRY

- Specjalnie opracowane pod kątem uzyskania wytrzymałości na naprężenia urządzeń udarowych (patrz rozdział 14) lub „Dynapact” (patrz rozdział 5). Stal specjalna i obróbka termiczna zapewniają wysoką granicę plastyczności i dużą wytrzymałość na zużycie.



BEZPIECZEŃSTWO

- Wszystkie narzędzia i akcesoria zawierają otwór i rowek zgodne z normami ISO 2725. Blokowanie odbywa się za pomocą kołka przechodzącego na wylot i pierścienia rozprężnego (do zamawiania oddzielnie). Nie należy nigdy używać chromowanych nasadek ręcznych na narzędziach udarowych.









⇒ Kołki	Ø x L (mm)
GA.15A	2,5 x 15,0
GA.18A	2,5 x 18,0
GA.20A	3,0 x 20,0
GA.24A	3,0 x 24,0
GA.37A	4,0 x 37,0
GA.43A	5,0 x 43,0
GA.75A	6,0 x 75,0
GA.84A	6,0 x 84,0

⇒ Pierścienie	Ø pierścienia x Ø wew. (mm)
BA.16A	2,4 x 16,0
BA.19A	2,4 x 19,0
BA.21A	2,4 x 21,0
BA.20A	3,5 x 20,2
BA.24A	3,5 x 24,0
BA.25A	3,5 x 25,0
BA.38A	3,5 x 38,0
BA.46A	3,5 x 46,0
BA.75A	5,7 x 75,0
BA.85A	5,7 x 85,0

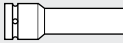

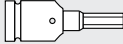
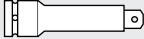
NASADKI I AKCESORIA UDAROWE

JAK WYBIERAĆ NARZĘDZIA UDAROWE?

TYPY NARZĘDZI	ZABIERAK	DOSTĘPNE WYMIARY
Nasadka 	<input checked="" type="checkbox"/> 3/8" <input checked="" type="checkbox"/> 1/2" <input checked="" type="checkbox"/> 3/4" <input checked="" type="checkbox"/> 1" <input checked="" type="checkbox"/> 1 1/2"	6 > 19 mm 8 > 32 mm ; 3/8" > 1"1/16 17 > 46 mm ; 3/4" > 1"5/8 21 > 77 mm 55 > 120 mm 12 16 > 22 mm
Nasadka Torx® 	<input checked="" type="checkbox"/> 1/2"	E10 > E24
Nasadka długa 	<input checked="" type="checkbox"/> 1/2" <input checked="" type="checkbox"/> 3/4" <input checked="" type="checkbox"/> 1"	8 > 32 mm 8 > 32 mm 17 > 46 mm 21 > 36 mm 22 > 70 mm 24 > 50 mm
Nasadka ekstra długa 	<input checked="" type="checkbox"/> 1"	30, 32, 33 mm
Nasadka wkrętakowa jednoelementowa 	<input checked="" type="checkbox"/> 1/2" <input checked="" type="checkbox"/> 3/4"	5 > 19 mm 17 > 24 mm T30 > T60
Przedłużacz 	<input checked="" type="checkbox"/> 3/8" <input checked="" type="checkbox"/> 1/2" <input checked="" type="checkbox"/> 3/4" <input checked="" type="checkbox"/> 1" <input checked="" type="checkbox"/> 1 1/2"	L : 76 - 150 mm L : 50 - 252 mm L : 100 - 330 mm L : 125 - 330 mm L : 250 - 330 mm
Przegub 	<input checked="" type="checkbox"/> 3/8" <input checked="" type="checkbox"/> 1/2"	1 model na zabierak kwadratowy
Reduktory 	<input checked="" type="checkbox"/> 3/8" <input checked="" type="checkbox"/> 1/2" <input checked="" type="checkbox"/> 3/4" <input checked="" type="checkbox"/> 1" <input checked="" type="checkbox"/> 1 1/2"	<input checked="" type="checkbox"/> 3/8" > <input checked="" type="checkbox"/> 1/2" <input checked="" type="checkbox"/> 3/8" > <input checked="" type="checkbox"/> 1/4" <input checked="" type="checkbox"/> 1/2" > <input checked="" type="checkbox"/> 3/4" <input checked="" type="checkbox"/> 1/2" > <input checked="" type="checkbox"/> 3/8" <input checked="" type="checkbox"/> 3/4" > <input checked="" type="checkbox"/> 1" <input checked="" type="checkbox"/> 3/4" > <input checked="" type="checkbox"/> 1" <input checked="" type="checkbox"/> 1" > <input checked="" type="checkbox"/> 1 1/2" <input checked="" type="checkbox"/> 1" > <input checked="" type="checkbox"/> 3/4" <input checked="" type="checkbox"/> 1 1/2" > <input checked="" type="checkbox"/> 2 1/2" <input checked="" type="checkbox"/> 1 1/2" > <input checked="" type="checkbox"/> 1"
Klucz Dynapact 	<input checked="" type="checkbox"/> 3/4" <input checked="" type="checkbox"/> 1"	1000 Nm 2000 Nm
Wkrętak do pobijania 	<input checked="" type="checkbox"/> 3/8" <input checked="" type="checkbox"/> 1/2"	200 Nm 400 Nm



Nasadki udarowe 3/8"

SERIA NASADEK I AKCESORIÓW UDAROWYCH \square 3/8"

DLA BEZPIECZEŃSTWA

- Dla Państwa bezpieczeństwa należy zawsze używać nasadek i akcesoriów udarowych z odpowiednimi pierścieniami i kołkami zabezpieczającymi.
- Nie należy nigdy używać nasadek lub akcesoriów ręcznych (chromowanych) na narzędziach udarowych.



NJ.A - Nasadki udarowe 3/8" 6-kątne metryczne

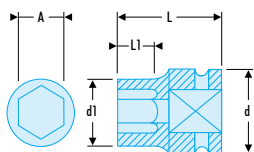

NF ISO 2725-2, NF ISO 1711-2, ISO 2725-2, ISO 1711-2, DIN 3129, ASME B107.33

- Dla Państwa bezpieczeństwa należy zawsze używać nasadek udarowych z odpowiednimi pierścieniami i kołkami zabezpieczającymi.

	A	ϕ	d	d1	GA	BA	L	L1	$\Delta\Delta$
	[mm]	[mm]	[mm]	[mm]			[mm]	[mm]	[g]
NJ.6A	6	6	19	11,5	GA.15A	BA.16A	30	6,0	38
NJ.7A	7	6	19	12,5	GA.15A	BA.16A	30	8,0	41
NJ.8A	8	6	19	14,0	GA.15A	BA.16A	30	8,0	41
NJ.9A	9	6	19	15,0	GA.15A	BA.16A	30	8,0	42
NJ.10A	10	6	19	16,5	GA.15A	BA.16A	30	8,0	41
NJ.11A	11	6	19	17,5	GA.15A	BA.16A	32	9,0	47
NJ.12A	12	6	19	19,0	GA.15A	BA.16A	30	9,0	49
NJ.13A	13	6	22	20,0	GA.18A	BA.19A	30	10,0	49
NJ.14A	14	6	22	21,5	GA.18A	BA.19A	30	11,5	63
NJ.15A	15	6	22	22,0	GA.18A	BA.19A	30	11,0	67
NJ.16A	16	6	22	24,0	GA.18A	BA.19A	30	12,5	72
NJ.17A	17	6	22	25,0	GA.18A	BA.19A	30	12,5	70
NJ.18A	18	6	22	26,5	GA.18A	BA.19A	30	12,5	73
NJ.19A	19	6	22	27,5	GA.18A	BA.19A	30	14,0	77

PRZYGOTUJ WŁASNY ZESTAW NASADEK - KOŃCÓWEK

Końcówki do przykręcania



- Seria 2 \square 5/16"
- Seria 3 \square 1/2"

▶ Patrz rozdział 7

Uchwyt końcówek udarowych \square 3/8"



NJ.236A
 \square 5/16"
7,94 mm



NJ.237A
 \square 1/2"
12,70 mm

▶ Patrz str. 322



NJ.A - Przedłużacze udarowe 3/8"

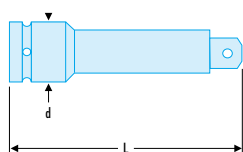

ASME B107.2

- Dla Państwa bezpieczeństwa należy zawsze używać przedłużaczy udarowych z odpowiednimi pierścieniami i kołkami zabezpieczającymi.

	d [mm]	GA	BA	L [mm]	$\Delta\Delta$ [g]
NJ.210A	19	GA.15A	BA.16A	75	95
NJ.211A	19	GA.15A	BA.16A	150	170

▣ Przegub udarowy 3/8"

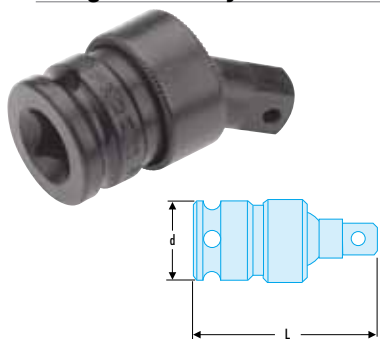

ASME B107.2

- Dla Państwa bezpieczeństwa należy zawsze używać przegubów udarowych z odpowiednimi pierścieniami i kołkami zabezpieczającymi.

⇒	d [mm]	GA	BA	L [mm]	ΔΔ [g]
NJ.240A	23.85	GA.18A	BA.20A	51	85

▣ NJ.A - Przekładnie udarowe 3/8"

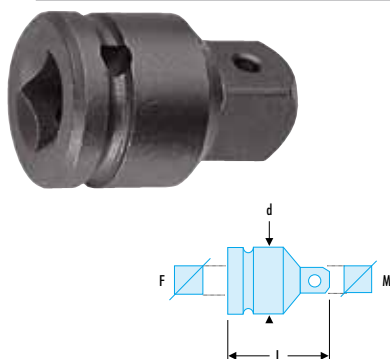

ASME B107.2

- Dla Państwa bezpieczeństwa należy zawsze używać przekładni udarowych z odpowiednimi pierścieniami i kołkami zabezpieczającymi.
- NJ.230A: reduktor do nasadek 1/4".
- NJ.232A: powiększacz do nasadek 1/2".

⇒	Kwadrat ["]	d [mm]	GA	BA	L [mm]	ΔΔ [g]
NJ.230A	F = 3/8" - M = 1/4"	22	GA.18A	BA.19A	32	40
NJ.232A	F = 3/8" - M = 1/2"	22	GA.18A	BA.19A	36	95

NARZĘDZIA ZENERGIZOWANE

FACOM POSIADA W OFERCIE LICZNE NARZĘDZIA PNEUMATYCZNE I ELEKTRONARZĘDZIA:

klucze udarowe, grzechotki, wkrętarki, wiertarki, szlifierki, szlifierki tarczowe, przecinaki pneumatyczne, ...

➤ **Patrz rozdział 14 str. 676**



Akcesoria udarowe 3/8"

▣ NJ.A - Nasadki udarowe z uchwytem do końcówek 3/8"

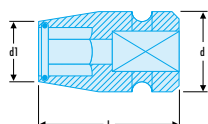

NF ISO 1711-2, ISO 1711-2, DIN 3121,

- NJ.236A: do końcówek 5/16".
- NJ.237A: do końcówek 1/2".

⇒	A ["]	Zabierak ["]	d [mm]	d1 [mm]	GA	BA	L [mm]	ΔΔ [g]
NJ.236A	5/16	3/8	19	14,0	GA.15A	BA.16A	37	35
NJ.237A	1/2	3/8	19	19	GA.15A	BA.16A	37	40

Nasadki udarowe 3/8" i końcówki

▣ **JHX.14** Zestaw 14 końcówek udarowych 3/8"



- Zawiera:
 - 2 nasadki z uchwytem końcówek: 3/8", śr. 1/2" i 5/16" (symbol NJ.236A i NJ.237A).
 - 6 końcówek udarowych 6-kątnych: 6 - 7 - 8 - 10 - 12 - 14 mm (symbol ENH.306 - ENH.307 - ENH.308 - ENH.310 - ENH.312 - ENH.314).
 - 5 końcówek udarowych Torx®: T30 - T40 - T45 - T50 - T55 (symbol NEX.30A - NEX.40A - NEX.45A - NEX.50A - NEX.55A).
 - 3 końcówki udarowe Philips: PH2 - PH3 - PH4 (symbol ENP.202 - ENP.203 - ENP.204).
 - Kasetka plastikowa BP.102, wym. (dł. x gł. x wys.): 204 x 122 x 52 mm.
 - Wkładka termoformowana PL.402A.
- Masa: 780 g.



Zestawy nasadek i akcesoriów udarowych 1/2"

▣ **NS.550A** Zestaw nasadek udarowych 1/2" krótkich i długich od 10 do 32 mm



- Zestaw przystosowany do wszystkich prac samochodowych: nasadki krótkie, nasadki długie, nasadki do felg aluminiowych (17 - 19 - 21 mm).
 - Dla Państwa bezpieczeństwa należy zawsze używać nasadek udarowych z odpowiednimi pierścieniami i kołkami zabezpieczającymi (dostarczanych w kasecie).
 - Zawiera:
 - Nasadki o długości standardowej: 10 - 11 - 12 - 13 - 14 - 15 - 16 - 17 - 18 - 19 - 21 - 22 - 24 - 27 - 30 - 32 mm.
 - Nasadki długie: 10 - 13 - 16 - 18 mm.
 - Nasadki do felg aluminiowych: 17 - 19 - 21 mm.
 - Przedłużacz: R.215A.
 - Dopasowane pierścienie i kołki.
 - Kasetka plastikowa BP.109 wym. (dł. x gł. x wys.): 478 x 234 x 72 mm.
 - Wkładka PL.716
- Masa: 5,10 kg.



▣ **NS.500A** Zestaw nasadek udarowych 1/2" od 8 do 27 mm



- Dla Państwa bezpieczeństwa należy zawsze używać nasadek udarowych z odpowiednimi pierścieniami i kołkami zabezpieczającymi.
 - Zawiera:
 - Nasadki: 8 - 9 - 10 - 11 - 12 - 13 - 14 - 15 - 16 - 17 - 18 - 19 - 21 - 22 - 24 - 27 mm.
 - Przegub: NS.240A.
 - Przedłużacz: NS.215A.
 - Dopasowane pierścienie i kołki.
 - Kasetka plastikowa BP.112, wym. (dł. x gł. x wys.): 389 x 164 x 66 mm.
 - Wkładka PL.416.
- Masa: 3,70 kg.



▣ NS.500AU Zestaw nasadek udarowych 1/2" od 3/8" do 11/16"



- Dla Państwa bezpieczeństwa należy zawsze używać nasadek udarowych z odpowiednimi pierścieniami i kołkami zabezpieczającymi.
 - Zawiera:
 - Nasadki NS: 3/8" --> 11/16".
 - Przegub: NS.240A.
 - Przedłużacz: NS.215A.
 - Dopasowane pierścienie i kołki.
 - Kasetka plastikowa BP.112, wym. (dł. x gł. x wys.): 389 x 164 x 66 mm.
 - Wkładka PL.417.
- Masa: 3,10 kg.

▣ NS.405A Zestaw nasadek udarowych 1/2" długich od 10 do 24 mm



- Dla Państwa bezpieczeństwa należy zawsze używać nasadek udarowych z odpowiednimi pierścieniami i kołkami zabezpieczającymi.
 - Zawiera:
 - Nasadki 1/2" długości: 10 - 11 - 12 - 13 - 14 - 16 - 17 - 19 - 21 - 22 - 23 - 24 mm.
 - Kasetka plastikowa BP.112, dim. (dł. x gł. x wys.): 389 x 164 x 66 mm.
 - Wkładka PL.418.
- Masa: 4 kg.

▣ NS.J9 Zestaw nasadek udarowych metrycznych 1/2" 6-kątnych na szynie



- Zawiera wymiary najczęściej stosowane w motoryzacji:
 - NS.13A - NS.14A - NS.16A - NS.17A - NS.18 - NS.19A - NS.21A - NS.22A - NS.24A.
 - Niezbędne uzupełnienie wszystkich kluczy udarowych 1/2".
 - Dostarczany na szynie (CKS.95).
- Masa: 1,20 kg.

▣ NSB.3 Zestaw 3 nasadek udarowych 1/2" długich, cienkościennych do nakrętek kół



- Zawiera nasadki długie NSB.17 - NSB.19 - NSB.21.
 - Seria specjalna do nakrętek kół.
- Masa: 740 g.

▣ **NSTX.J7** Zestaw 7 nasadek Torx® 1/2" 6-kątnych na szynie



- Dla Państwa bezpieczeństwa należy zawsze używać nasadek uderowych z odpowiednimi pierścieniami i kołkami zabezpieczającymi.
- Zestaw 7 nasadek uderowych Torx® 1/2".
- Zawiera:
 - NSTX: E10 - E12 - E14 - E16 - E18 - E20 - E24.
- Dostarczany na szynie (CKS.97).
- Masa: 770 g.



▣ **NSHM.J8** Zestaw 8 nasadek do wkrętaka 1/2" do śrub z gniazdem 6-kątym na szynie



- Dla Państwa bezpieczeństwa należy zawsze używać nasadek uderowych z odpowiednimi pierścieniami i kołkami zabezpieczającymi.
- Zestaw 8 nasadek do wkrętaka 1/2" do śrub z gniazdem 6-kątym.
- Zawiera następujące rozmiary: NSHM.5, 6, 8, 10, 12, 14, 17, 19.
- Dostarczany na szynie (CKS.95).
- Masa: 1,20 kg.



▣ **NHX.14A** Zestaw 14 końcówek uderowych 1/2"



- Zawiera:
 - 2 nasadki z uchwytem do końcówek 1/2", śr. 1/2" i 5/16".
 - 6-kątne: 6 - 7 - 8 - 10 - 12 et 14 mm.
 - Torx®: n°30 - n°40 - n°45 - n°50 - n°55.
 - Phillips®: 2 - 3 - 4.
 - Kasetka plastikowa BP.102.
 - Wkładka PL.402A.
- Masa: 800 g.



▣ **MOD.NS1** Moduł nasadek uderowych 1/2" 6-kątnych metrycznych



- Zawiera:
 - NSA 10 - 11 - 12 - 13 - 14 - 15 - 16 - 17 - 18 - 19 - 21 - 22 - 23 - 24 mm: Nasadki uderowe 1/2" krótkie.
 - NS215A: Przedłużacz 1/2" 125 mm.
 - Wkładka termoformowana PL. 610.
- Masa: 2,000 kg.

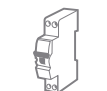

MOD.NS2 Moduł nasadek udarowych 1/2" 6-kątnych metrycznych



- Zawiera:
 - NS.A 13 - 14 - 15 - 16 - 17 - 18 - 19 - 21 - 22 - 24 - 27 - 30 - 32: Nasadki udarowe 1/2" krótkie.
 - NS.236A i NS.237A: Nasadki udarowe 1/2" z uchwytem do końcówek.
 - Końcówki udarowe: ENH.3 6 - 7 - 8 - 10 - 12 - 14 ; ENP.2 2 - 3 - 4 ; NEX.A 30 - 40 - 45 - 50 - 55.
 - Wkładka termoformowana: PL.623.
- Masa: 985 g.

Nasadki i akcesoria udarowe 1/2"

NS.A - Nasadki udarowe 1/2" 6-kątne metryczne

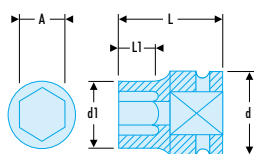

NF ISO 2725-2, NF ISO 1711-2, ISO 2725-2, ISO 1711-2, DIN 3129, ASME B107.33

- Dla Państwa bezpieczeństwa należy zawsze używać nasadek udarowych z odpowiednimi pierścieniami i kołkami zabezpieczającymi.

⇒	A [mm]	⊙ [mm]	d [mm]	d1 [mm]	GA	BA	L [mm]	L1 [mm]	ΔΔ [g]
NS.8A	8	6	25	15,0	GA.20A	BA.20A	38	9	70
NS.9A	9	6	25	16,0	GA.20A	BA.20A	38	12	70
NS.10A	10	6	25	17,5	GA.20A	BA.20A	38	12	75
NS.11A	11	6	25	18,7	GA.20A	BA.20A	38	12	76
NS.12A	12	6	25	20,0	GA.20A	BA.20A	38	12	75
NS.13A	13	6	25	21,0	GA.20A	BA.20A	38	12	76
NS.14A	14	6	25	22,5	GA.20A	BA.20A	38	12	83
NS.15A	15	6	30	23,7	GA.24A	BA.25A	38	12	112
NS.16A	16	6	30	25,0	GA.24A	BA.25A	38	12	105
NS.17A	17	6	30	26,5	GA.24A	BA.25A	38	13	112
NS.18A	18	6	30	27,5	GA.24A	BA.25A	38	13	110
NS.19A	19	6	30	29,0	GA.24A	BA.25A	38	14	112
NS.20A	20	6	30	30,0	GA.24A	BA.25A	38	15	116
NS.21A	21	6	30	31,0	GA.24A	BA.25A	38	15	156
NS.22A	22	6	30	32,5	GA.24A	BA.25A	38	16	156
NS.23A	23	6	30	33,5	GA.24A	BA.25A	38	16	156
NS.24A	24	6	30	35,0	GA.24A	BA.25A	45	20	169
NS.26A	26	6	30	38,0	GA.24A	BA.25A	50	24	192
NS.27A	27	6	30	39,0	GA.24A	BA.25A	50	24	220
NS.28A	28	6	30	40,0	GA.24A	BA.25A	50	24	273
NS.29A	29	6	30	41,0	GA.24A	BA.25A	50	24	276
NS.30A	30	6	30	43,0	GA.24A	BA.25A	50	24	285
NS.32A	32	6	30	45,0	GA.24A	BA.25A	50	24	278

NS.A - Nasadki udarowe 1/2" 6-kątne calowe

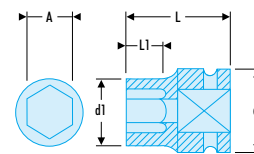

ASME B107.2

- Dla Państwa bezpieczeństwa należy zawsze używać nasadek udarowych z odpowiednimi pierścieniami i kołkami zabezpieczającymi.

⇒	A ["]	⊙ [mm]	d [mm]	d1 [mm]	GA	BA	L [mm]	L1 [mm]	ΔΔ [g]
NS.3/8A	3/8	6	25	17,5	GA.20A	BA.20A	38	12	75
NS.7/16A	7/16	6	25	18,7	GA.20A	BA.20A	38	12	76
NS.1/2A	1/2	6	25	21,0	GA.20A	BA.20A	38	12	76
NS.9/16A	9/16	6	25	22,5	GA.20A	BA.20A	38	12	83
NS.5/8A	5/8	6	30	25,0	GA.24A	BA.25A	38	12	105
NS.11/16A	11/16	6	30	26,5	GA.24A	BA.25A	38	13	112
NS.3/4A	3/4	6	30	29,0	GA.24A	BA.25A	38	14	112
NS.13/16A	13/16	6	30	31,0	GA.24A	BA.25A	38	15	156
NS.7/8A	7/8	6	30	33,5	GA.24A	BA.25A	38	16	162
NS.15/16A	15/16	6	30	33,5	GA.24A	BA.25A	38	16	162
NS.1'A	1'	6	30	38,0	GA.24A	BA.25A	50	24	192
NS.1'1/16A	1' 1/16	6	30	39,0	GA.24A	BA.25A	50	24	220

NS.LA - Nasadki udarowe 1/2" długie 6-kątne metryczne

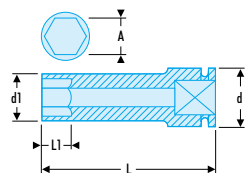

NF ISO 2725-2, NF ISO 1711-2, ISO 2725-2, ISO 1711-2, DIN 3129, ASME B107.33

- Dla Państwa bezpieczeństwa należy zawsze używać nasadek udarowych z odpowiednimi pierścieniami i kołkami zabezpieczającymi.

➤	A [mm]	⌀ [mm]	d [mm]	d1 [mm]	GA	BA	L [mm]	L1 [mm]	ΔΔ [g]
NS.8LA	8	6	25	15,0	GA.20A	BA.20A	78	13	130
NS.10LA	10	6	25	17,5	GA.20A	BA.20A	78	14	154
NS.11LA	11	6	25	18,7	GA.20A	BA.20A	78	14	163
NS.12LA	12	6	25	20,0	GA.20A	BA.20A	78	14	169
NS.13LA	13	6	25	21,0	GA.20A	BA.20A	78	14	185
NS.14LA	14	6	25	22,5	GA.20A	BA.20A	78	17	201
NS.16LA	16	6	30	25,0	GA.24A	BA.25A	78	17	224
NS.17LA	17	6	30	26,0	GA.24A	BA.25A	78	17	252
NS.18LA	18	6	30	27,5	GA.24A	BA.25A	78	17	283
NS.19LA	19	6	30	29,0	GA.24A	BA.25A	78	19	268
NS.21LA	21	6	30	31,0	GA.24A	BA.25A	78	24	310
NS.22LA	22	6	30	32,5	GA.24A	BA.25A	78	24	302
NS.23LA	23	6	30	33,5	GA.24A	BA.25A	78	24	298
NS.24LA	24	6	30	35,0	GA.24A	BA.25A	78	24	309
NS.26LA	26	6	30	38,0	GA.24A	BA.25A	78	24	311
NS.27LA	27	6	30	39,0	GA.24A	BA.25A	78	24	325
NS.28LA	28	6	30	40,0	GA.24A	BA.25A	78	24	323
NS.29LA	29	6	30	41,0	GA.24A	BA.25A	78	24	357
NS.30LA	30	6	30	43,0	GA.24A	BA.25A	78	24	352
NS.32LA	32	6	30	45,0	GA.24A	BA.25A	78	24	317

NSB - Nasadki udarowe 1/2" długie cienkościenne 6-kątne metryczne

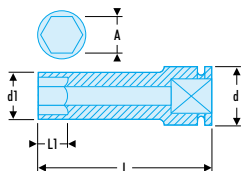

NF ISO 2725-2, NF ISO 1711-2, ISO 2725-2, ISO 1711-2, DIN 3129, ASME B107.33

- Dla Państwa bezpieczeństwa należy zawsze używać nasadek udarowych z odpowiednimi pierścieniami i kołkami zabezpieczającymi.
- Cienkie ścianki umożliwiające pracę w miejscach trudno dostępnych.
- Profil 6-kątny wypukły dla lepszej wytrzymałości.

➤	A [mm]	⌀ [mm]	d1 [mm]	GA	BA	L [mm]	L1 [mm]	ΔΔ [g]
NSB.8	8	6	13,0	GA.20A	BA.20A	80	8	165
NSB.10	10	6	15,0	GA.20A	BA.20A	80	10	170
NSB.13	13	6	19,0	GA.20A	BA.20A	80	13	210
NSB.15	15	6	22,0	GA.24A	BA.25A	80	15	220
NSB.16	16	6	23,0	GA.24A	BA.25A	80	16	230
NSB.17	17	6	24,0	GA.24A	BA.25A	80	17	245
NSB.18	18	6	25,5	GA.24A	BA.25A	80	18	245
NSB.19	19	6	27,0	GA.24A	BA.25A	80	19	240
NSB.21	21	6	30,0	GA.24A	BA.25A	80	22	245
NSB.22	22	6	31,0	GA.24A	BA.25A	85	23	250
NSB.24	24	6	32,0	GA.24A	BA.25A	85	24	280
NSB.27	27	6	36,0	GA.24A	BA.25A	85	27	325
NSB.30	30	6	39,0	GA.24A	BA.25A	85	30	330
NSB.32	32	6	41,0	GA.24A	BA.25A	85	32	335

NASADKI DO FELG ALUMINIOWYCH

- NSAL.3 = zestaw 3 nasadek długich o cienkich ściankach z zabezpieczeniem plastikowym, specjalne do felg aluminiowych.

➤ Patrz rozdział 19 str. 954



▣ NSTX - Nasadki udarowe 1/2" Torx®

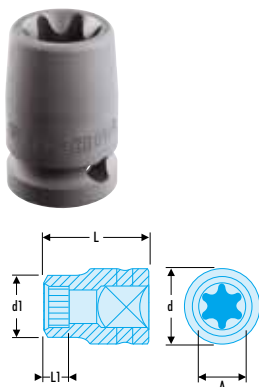

- Dla Państwa bezpieczeństwa należy zawsze używać nasadek udarowych z odpowiednimi pierścieniami i kołkami zabezpieczającymi.
- Do śrub z trzpieniem Torx®.

⇒	A [mm]	Torx [Nr]	d [mm]	d1 [mm]	GA	BA	L [mm]	ΔΔ [g]
NSTX.10	9,19	E10	25	14,2	GA.20A	BA.20A	38	86
NSTX.12	10,95	E12	25	15,2	GA.20A	BA.20A	38	85
NSTX.14	12,67	E14	25	18,2	GA.20A	BA.20A	38	88
NSTX.16	14,70	E16	25	19,2	GA.20A	BA.20A	38	88
NSTX.18	16,38	E18	25	22,2	GA.20A	BA.20A	38	89
NSTX.20	18,16	E20	30	24,2	GA.24A	BA.24A	38	134
NSTX.24	21,84	E24	30	28,2	GA.24A	BA.24A	40	138

▣ NSX - Nasadki wkrętakowe udarowe 1/2" z końcówką Torx®

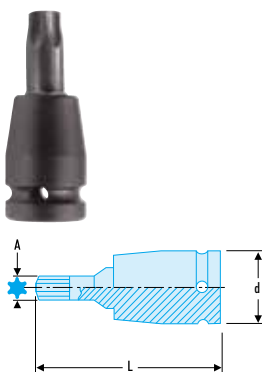

- Dla Państwa bezpieczeństwa należy zawsze używać nasadek udarowych z odpowiednimi pierścieniami i kołkami zabezpieczającymi.
- Do wkrętów z gniazdem Torx®.

⇒	A [mm]	Torx [Nr]	d [mm]	Końcówki	L [mm]	ΔΔ [g]
NSX.30A	5,49	T30	25	NEX.30A	70	90
NSX.40A	6,60	T40	25	NEX.40A	70	95
NSX.45A	7,77	T45	25	NEX.45A	70	95
NSX.50A	8,79	T50	25	NEX.50A	70	100
NSX.55A	11,17	T55	25	NEX.55A	70	105
NSX.60A	13,20	T60	25	NEX.60A	70	110

▣ NSHM - Nasadki wkrętakowe udarowe 1/2" do śrub z gniazdem 6-kątnym metrycznych

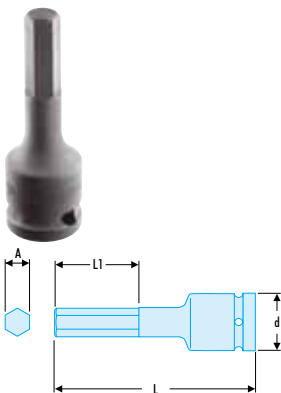

- Dla Państwa bezpieczeństwa należy zawsze używać nasadek udarowych z odpowiednimi pierścieniami i kołkami zabezpieczającymi.
- Nasadka wkrętakowa jednoelementowa

⇒	A [mm]	⌀ [mm]	d [mm]	GA	BA	L [mm]	L1 [mm]	ΔΔ [g]
NSHM.5	5	6	25	GA.20A	BA.20A	75	20	60
NSHM.6	6	6	25	GA.20A	BA.20A	75	20	60
NSHM.8	8	6	25	GA.20A	BA.20A	75	25	80
NSHM.10	10	6	25	GA.20A	BA.20A	75	25	100
NSHM.12	12	6	25	GA.20A	BA.20A	75	25	120
NSHM.14	14	6	25	GA.20A	BA.20A	75	25	120
NSHM.17	17	6	25	GA.20A	BA.20A	75	25	160
NSHM.19	19	6	25	GA.20A	BA.20A	75	25	180

▣ NS.A - Nasadki z uchwytem do końcówek 1/2"

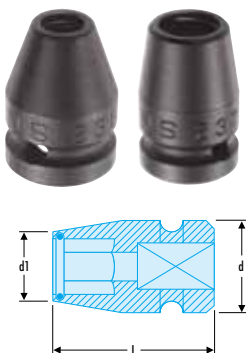

NF ISO 1711-2, ISO 1711-2, DIN 3121

- NS.236: do końcówek 5/16".
- NS.237: do końcówek 1/2".

⇒	A ["]	Kwadrat ["]	d [mm]	d1 [mm]	GA	BA	L [mm]	ΔΔ [g]
NS.236A	5/16	1/2	25	15,5	GA.20A	BA.20A	40	65
NS.237A	1/2	1/2	25	20	GA.20A	BA.20A	40	40

NS.A - Przedłużacze udarowe 3/2"

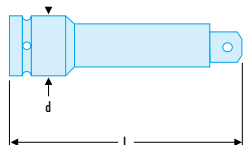

ASME B107.2

- Dla Państwa bezpieczeństwa należy zawsze używać przedłużaczy udarowych z odpowiednimi pierścieniami i kołkami zabezpieczającymi.

➤	d [mm]	GA	BA	L [mm]	ΔΔ [g]
NS.210A	25	GA.20A	BA.20A	50	105
NS.215A	25	GA.20A	BA.20A	125	235
NS.218A	25	GA.20A	BA.20A	175	370
NS.219A	25	GA.20A	BA.20A	250	520

Przegub udarowy 1/2"

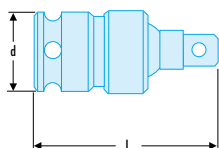

ASME B107.2

- Dla Państwa bezpieczeństwa należy zawsze używać przegubów udarowych z odpowiednimi pierścieniami i kołkami zabezpieczającymi.

➤	d [mm]	GA	BA	L [mm]	ΔΔ [g]
NS.240A	27,9	GA.24A	BA.24A	60	205

Przełożenie udarowe z 1/2" do 3/4"

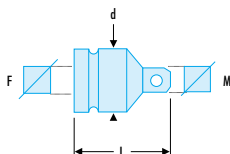

ASME B107.2

- Dla Państwa bezpieczeństwa należy zawsze używać przekładni udarowych z odpowiednimi pierścieniami i kołkami zabezpieczającymi.

➤	Kwadrat ["]	d [mm]	GA	BA	L [mm]	ΔΔ [g]
NS.232B	F = 1/2" - M = 3/4"	31	GA.24A	BA.25A	50	185

Reduktor udarowy z 1/2" do 3/8"

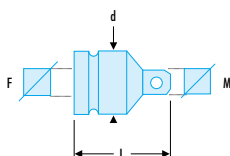

ASME B107.2

- Dla Państwa bezpieczeństwa należy zawsze używać reduktorów udarowych z odpowiednimi pierścieniami i kołkami zabezpieczającymi.

➤	Kwadrat ["]	d [mm]	GA	BA	L [mm]	ΔΔ [g]
NS.230A	F = 1/2" - M = 3/8"	25	GA.20A	BA.20A	41	90

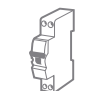
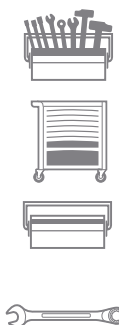

▣ **NK.500E** Zestaw nasadek udarowych 3/4" od 19 do 42 mm



- Dla Państwa bezpieczeństwa należy zawsze używać nasadek udarowych z odpowiednimi pierścieniami i kołkami zabezpieczającymi.
- Zawiera:
 - Nasadki: NK.19A - NK.21A - NK.22A - NK.23A - NK.24A - NK.26A - NK.27A - NK.28A - NK.29A - NK.30A - NK.32A - NK.34A - NK.36A - NK.38A - NK.41A - NK.42A.
 - Pierścienie: BA.38A.
 - Kołki: GA.37A.
 - Akcesoria: NK.210A i NS.240A.
 - Skrzynka metalowa BT.111, wym. (dł. x gł. x wys.): 396 x 224 x 82 mm.
 - Wkładka PL.79A.
- Masa: 12,40 kg.

▣ **NK.500U** Zestaw nasadek udarowych 3/4" od 3/4" do 1"5/8



- Dla Państwa bezpieczeństwa należy zawsze używać nasadek udarowych z odpowiednimi pierścieniami i kołkami zabezpieczającymi.
- Zawiera:
 - Nasadki: NK.1"1/16A - NK.1"1/2A - NK.1"1/4A - NK.1"1/8A - NK.13/16A - NK.15/16A - NK.1"5/16A - NK.1"5/8A - NK.1"7/16A - NK.1"A - NK.3/4A - NK.7/8A.
 - Kołek: GA.37A.
 - Pierścień: BA.38A.
 - Akcesoria: NK.210A i NK.240A.
 - Skrzynka metalowa BT.111, wym. (dł. x gł. x wys.): 396 x 224 x 82 mm.
 - Wkładka PL.80A.
- Masa: 10,30 kg.

NARZĘDZIA ZENERGIZOWANE FACOM

FACOM POSIADA W OFERCIE LICZNE NARZĘDZIA PNEUMATYCZNE I ELEKTRONARZĘDZIA:

klucze udarowe, grzechotki, wkrętarki, wiertarki, szlifierki, szlifierki tarczowe, przecinaki pneumatyczne, ...

▶ Patrz rozdział 14 str. 676



Nasadki i akcesoria udarowe 3/4"

NK.A - Nasadki udarowe 3/4" 6-kątne metryczne

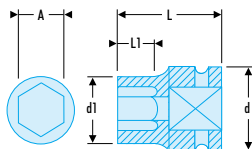

NF ISO 2725-2, NF ISO 1711-2, ISO 2725-2, ISO 1711-2, DIN 3129, ASME B107.33

• Dla Państwa bezpieczeństwa należy zawsze używać nasadek udarowych z odpowiednimi pierścieniami i kołkami zabezpieczającymi.

№	A [mm]	⌀ [mm]	d [mm]	d1 [mm]	GA	BA	L [mm]	L1 [mm]	ΔΔ [g]
NK.17A	17	6	44	30	GA.37A	BA.38A	52	12	300
NK.18A	18	6	44	32	GA.37A	BA.38A	50	13	310
NK.19A	19	6	44	33	GA.37A	BA.38A	50	14	315
NK.21A	21	6	44	35	GA.37A	BA.38A	50	15	330
NK.22A	22	6	44	37	GA.37A	BA.38A	50	16	345
NK.23A	23	6	44	38	GA.37A	BA.38A	50	16	350
NK.24A	24	6	44	39	GA.37A	BA.38A	50	17	350
NK.26A	26	6	44	42	GA.37A	BA.38A	50	18	480
NK.27A	27	6	44	43	GA.37A	BA.38A	54	23	480
NK.28A	28	6	44	44	GA.37A	BA.38A	54	23	520
NK.29A	29	6	44	45	GA.37A	BA.38A	54	23	520
NK.30A	30	6	44	47	GA.37A	BA.38A	54	23	545
NK.32A	32	6	44	49	GA.37A	BA.38A	56	23	620
NK.33A	33	6	44	51	GA.37A	BA.38A	56	23	650
NK.34A	34	6	44	52	GA.37A	BA.38A	56	23	680
NK.35A	35	6	44	53	GA.37A	BA.38A	56	23	680
NK.36A	36	6	44	54	GA.37A	BA.38A	56	25	705
NK.38A	38	6	44	57	GA.37A	BA.38A	58	26	890
NK.41A	41	6	44	60	GA.37A	BA.38A	58	28	890
NK.42A	42	6	44	62	GA.37A	BA.38A	58	29	925
NK.46A	46	6	44	67	GA.37A	BA.38A	63	32	1055

NK.A - Nasadki udarowe 3/4" 6-kątne calowe

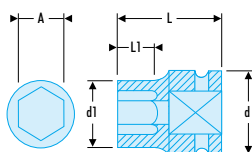

ASME B107.2

• Dla Państwa bezpieczeństwa należy zawsze używać nasadek udarowych z odpowiednimi pierścieniami i kołkami zabezpieczającymi.

№	A ["]	⌀ [mm]	d [mm]	d1 [mm]	GA	BA	L [mm]	L1 [mm]	ΔΔ [g]
NK.3/4A	3/4	6	44	33	GA.37A	BA.38A	50	14	315
NK.13/16A	13/16	6	44	35	GA.37A	BA.38A	50	15	330
NK.7/8A	7/8	6	44	37	GA.37A	BA.38A	50	16	345
NK.15/16A	15/16	6	44	39	GA.37A	BA.38A	50	17	350
NK.1"A	1"	6	44	41	GA.37A	BA.38A	50	18	480
NK.1 1/16A	1 1/16	6	44	43	GA.37A	BA.38A	54	23	480
NK.1 1/8A	1 1/8	6	44	44	GA.37A	BA.38A	54	23	520
NK.1 1/4A	1 1/4	6	44	49	GA.37A	BA.38A	56	23	620
NK.1 5/16A	1 5/16	6	44	53	GA.37A	BA.38A	56	23	680
NK.1 7/16A	1 7/16"	6	44	55	GA.37A	BA.38A	56	24	515
NK.1 1/2A	1 1/2	6	44	57	GA.37A	BA.38A	58	26	890
NK.1 5/8A	1 5/8	6	44	60	GA.37A	BA.38A	58	28	890



█ NKD - Nasadki udarowe 3/4" 12-kątne metryczne

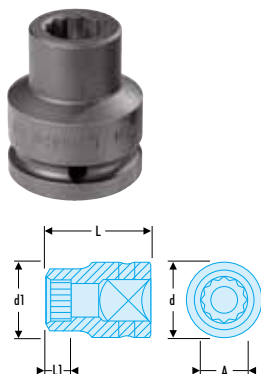

NF ISO 2725-2, NF ISO 1711-2, ISO 2725-2, ISO 1711-2, DIN 3129, ASME B107.33

- Dla Państwa bezpieczeństwa należy zawsze używać nasadek udarowych z odpowiednimi pierścieniami i kołkami zabezpieczającymi.

⇒	A [mm]	⌀ [mm]	d [mm]	d1 [mm]	GA	BA	L [mm]	L1 [mm]	ΔΔ [g]
NKD.16A	16	12	44	29,0	GA.37A	BA.38A	52	12	300
NKD.17A	17	12	44	30,0	GA.37A	BA.38A	52	12	305
NKD.18A	18	12	44	31,5	GA.37A	BA.38A	52	14	310
NKD.19A	19	12	44	32,5	GA.37A	BA.38A	52	14	315
NKD.22A	22	12	44	36,5	GA.37A	BA.38A	52	16	340

█ NK.LA - Nasadki udarowe 3/4" długie 6-kątne metryczne



NF ISO 2725-2, NF ISO 1711-2, ISO 2725-2, ISO 1711-2, DIN 3129, ASME B107.33

- Dla Państwa bezpieczeństwa należy zawsze używać nasadek udarowych z odpowiednimi pierścieniami i kołkami zabezpieczającymi.

⇒	A [mm]	⌀ [mm]	d [mm]	d1 [mm]	GA	BA	L [mm]	L1 [mm]	ΔΔ [g]
NK.17LA	17	6	44	31	GA.37A	BA.38A	95	17	550
NK.19LA	19	6	44	33	GA.37A	BA.38A	95	17	620
NK.21LA	21	6	44	35	GA.37A	BA.38A	95	24	600
NK.22LA	22	6	44	37	GA.37A	BA.38A	95	24	780
NK.23LA	23	6	44	38	GA.37A	BA.38A	95	24	780
NK.24LA	24	6	44	39	GA.37A	BA.38A	95	24	820
NK.26LA	26	6	44	42	GA.37A	BA.38A	95	24	800
NK.27LA	27	6	44	43	GA.37A	BA.38A	95	24	810
NK.29LA	29	6	44	45	GA.37A	BA.38A	95	24	890
NK.30LA	30	6	44	47	GA.37A	BA.38A	95	24	900
NK.32LA	32	6	44	49	GA.37A	BA.38A	95	24	930
NK.33LA	33	6	44	51	GA.37A	BA.38A	95	24	980
NK.34LA	34	6	44	52	GA.37A	BA.38A	95	24	1100
NK.35LA	35	6	44	53	GA.37A	BA.38A	95	24	1240
NK.36LA	36	6	44	54	GA.37A	BA.38A	95	25	1240
NK.38LA	38	6	44	57	GA.37A	BA.38A	95	60	1220
NK.41LA	41	6	44	60	GA.37A	BA.38A	95	60	1470
NK.42LA	42	6	44	62	GA.37A	BA.38A	95	60	1450
NK.46LA	46	6	44	67	GA.37A	BA.38A	95	60	1480

█ NKB - Nasadki udarowe 3/4" długie cienkościenne 6-kątne metryczne



NF ISO 2725-2, NF ISO 1711-2, ISO 2725-2, ISO 1711-2, DIN 3129, ASME B107.33

- Dla Państwa bezpieczeństwa należy zawsze używać nasadek udarowych z odpowiednimi pierścieniami i kołkami zabezpieczającymi.
- Cienkie ścianki umożliwiające pracę w miejscach trudno dostępnych.
- Profil 6-kątny wypukły dla lepszej wytrzymałości.

⇒	A [mm]	⌀ [mm]	d1 [mm]	GA	BA	L [mm]	L1 [mm]	ΔΔ [g]
NKB.21	21	6	33	GA.37A	BA.38A	102	21	600
NKB.22	22	6	34	GA.37A	BA.38A	102	22	600
NKB.24	24	6	36	GA.37A	BA.38A	102	24	640
NKB.27	27	6	40	GA.37A	BA.38A	102	27	670
NKB.30	30	6	43	GA.37A	BA.38A	102	30	700
NKB.32	32	6	46	GA.37A	BA.38A	102	32	706
NKB.33	33	6	48	GA.37A	BA.38A	102	33	750
NKB.36	36	6	50	GA.37A	BA.38A	102	36	765

NKHM - Nasadki trzpieniowe udarowe 3/4" do śrub z gniazdem 6-kątnym metrycznych

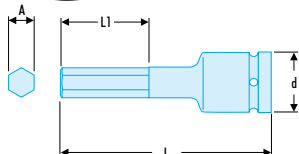

- Dla Państwa bezpieczeństwa należy zawsze używać nasadek udarowych z odpowiednimi pierścieniami i kołkami zabezpieczającymi.
- Nasadki trzpieniowe monolityczne.

№	A [mm]	⌀ [mm]	d [mm]	GA	BA	L [mm]	L1 [mm]	ΔΔ [g]
NKHM.17	17	6	44	GA.37A	BA.38A	100	20	600
NKHM.19	19	6	44	GA.37A	BA.38A	100	20	600
NKHM.22	22	6	44	GA.37A	BA.38A	100	20	600
NKHM.24	24	6	44	GA.37A	BA.38A	100	20	600

NK.A - Przedłużacze udarowe 3/4"

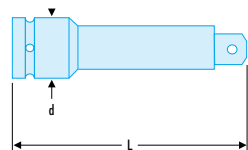

ASME B107.2

- Dla Państwa bezpieczeństwa należy zawsze używać przedłużaczy udarowych z odpowiednimi pierścieniami i kołkami zabezpieczającymi.

№	d [mm]	GA	BA	L [mm]	ΔΔ [g]
NK.209A	44	GA.37A	BA.38A	100	600
NK.210A	44	GA.37A	BA.38A	175	105
NK.215A	44	GA.37A	BA.38A	252	117
NK.218A	44	GA.37A	BA.38A	330	151



Przegub udarowy 3/4"

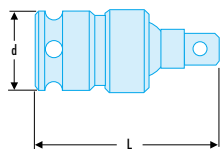

ASME B107.2

- Dla Państwa bezpieczeństwa należy zawsze używać przegubów udarowych z odpowiednimi pierścieniami i kołkami zabezpieczającymi.

№	d [mm]	GA	BA	L [mm]	ΔΔ [g]
NK.240A	44	GA.37A	BA.38A	90	720



Reduktor udarowy z 3/4" do 1/2"

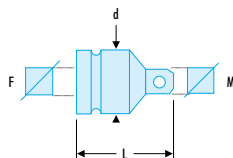

ASME B107.2

- Dla Państwa bezpieczeństwa należy zawsze używać przekładni udarowych z odpowiednimi pierścieniami i kołkami zabezpieczającymi.

➤	Kwadrat ["]	d [mm]	GA	BA	L [mm]	ΔΔ [g]
NK.230A	F = 3/4" - M = 1"	54	GA.37A	BA.38A	75	210

Przełożenie udarowe z 3/4" do 1"

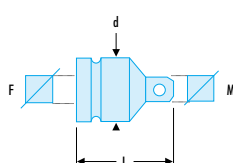

ASME B107.2

- Dla Państwa bezpieczeństwa należy zawsze używać nasadek udarowych z odpowiednimi pierścieniami i kołkami zabezpieczającymi.

➤	Kwadrat ["]	d [mm]	GA	BA	L [mm]	ΔΔ [g]
NK.232A	F = 3/4" - M = 1"	43	GA.37A	BA.38A	71	525

Nasadki i akcesoria udarowe 1"

NM.A - Nasadki udarowe 1" 6-kątne metryczne

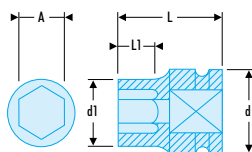

NF ISO 2725-2, NF ISO 1711-2, ISO 2725-2, ISO 1711-2, DIN 3129, ASME B107.33

- Dla Państwa bezpieczeństwa należy zawsze używać nasadek udarowych z odpowiednimi pierścieniami i kołkami zabezpieczającymi.

➤	A [mm]	⊙ [mm]	d [mm]	d1 [mm]	GA	BA	L [mm]	L1 [mm]	ΔΔ [kg]
NM.21A	21	6	54	38	GA.43A	BA.46A	58	17	0,520
NM.22A	22	6	54	40	GA.43A	BA.46A	58	17	0,500
NM.23A	23	6	54	41	GA.43A	BA.46A	58	17	0,500
NM.24A	24	6	54	42	GA.43A	BA.46A	58	17	0,500
NM.26A	26	6	54	44	GA.43A	BA.46A	58	18	0,520
NM.27A	27	6	54	46	GA.43A	BA.46A	58	19	0,520
NM.28A	28	6	54	47	GA.43A	BA.46A	58	20	0,520
NM.29A	29	6	54	48	GA.43A	BA.46A	60	20	0,520
NM.30A	30	6	54	50	GA.43A	BA.46A	60	20	0,750
NM.32A	32	6	54	52	GA.43A	BA.46A	60	22	0,760
NM.33A	33	6	54	53	GA.43A	BA.46A	60	22	0,750
NM.34A	34	6	54	55	GA.43A	BA.46A	62	23	0,750
NM.35A	35	6	54	56	GA.43A	BA.46A	62	26	0,800
NM.36A	36	6	54	57	GA.43A	BA.46A	65	26	0,840
NM.38A	38	6	54	60	GA.43A	BA.46A	65	30	0,840
NM.41A	41	6	54	63	GA.43A	BA.46A	67	30	1,040
NM.42A	42	6	54	65	GA.43A	BA.46A	74	35	1,040
NM.46A	46	6	54	70	GA.43A	BA.46A	74	35	1,500
NM.50A	50	6	54	75	GA.43A	BA.46A	80	40	1,650
NM.52A	52	6	54	77	GA.43A	BA.46A	84	42	1,750
NM.54A	54	6	54	80	GA.43A	BA.46A	84	42	1,790
NM.55A	55	6	54	81	GA.43A	BA.46A	84	42	1,840
NM.56A	56	6	54	82	GA.43A	BA.46A	84	42	2,060
NM.58A	58	6	54	85	GA.43A	BA.46A	87	44	2,190
NM.60A	60	6	54	87	GA.43A	BA.46A	87	44	2,370
NM.65A	65	6	54	93	GA.43A	BA.46A	90	46	2,730
NM.70A	70	6	54	100	GA.43A	BA.46A	96	50	2,980
NM.75A	75	6	86	106	GA.75A	BA.75A	98	50	3,300
NM.77A	77	6	86	109	GA.75A	BA.75A	100	50	3,500

NM.A - Nasadki udarowe 1" 6-kątne calowe

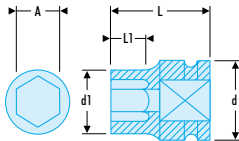

ASME B107.2

- Dla Państwa bezpieczeństwa należy zawsze używać nasadek udarowych z odpowiednimi pierścieniami i kołkami zabezpieczającymi.

⇒	A ["]	⌀ [mm]	d [mm]	d1 [mm]	GA	BA	L [mm]	L1 [mm]	ΔΔ [kg]
NM.1'A	1"	6	54	44	GA.43A	BA.46A	58	18	0,520
NM.1'1/8A	1 1/8"	6	54	48	GA.43A	BA.46A	60	20	0,520
NM.1'1/4A	1 1/4"	6	54	52	GA.43A	BA.46A	60	22	0,760
NM.1'5/16A	1 5/16"	6	54	54	GA.43A	BA.46A	62	22	0,750
NM.1'1/2A	1 1/2"	6	54	60	GA.43A	BA.46A	65	30	1,620
NM.1'5/8A	1 5/8"	6	54	63	GA.43A	BA.46A	67	30	1,040
NM.1'13/16A	1 13/16"	6	54	70	GA.43A	BA.46A	74	35	1,500
NM.1'7/8A	1 7/8"	6	54	72	GA.43A	BA.46A	74	35	1,620
NM.2'A	2"	6	54	77	GA.43A	BA.46A	84	42	1,750
NM.2'1/8A	2 1/8"	6	54	80	GA.43A	BA.46A	84	42	1,790

NM.LA - Nasadki udarowe 1" długie 6-kątne metryczne

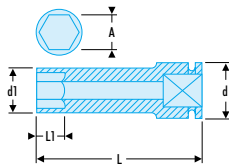

NF ISO 2725-2, NF ISO 1711-2, ISO 2725-2, ISO 1711-2, DIN 3129, ASME B107.33

- Dla Państwa bezpieczeństwa należy zawsze używać nasadek udarowych z odpowiednimi pierścieniami i kołkami zabezpieczającymi.

⇒	A [mm]	⌀ [mm]	d [mm]	d1 [mm]	GA	BA	L [mm]	L1 [mm]	ΔΔ [kg]
NM.22LA	22	6	54	40,0	GA.43A	BA.46A	100	21	1,000
NM.23LA	23	6	54	41,0	GA.43A	BA.46A	100	21	1,050
NM.24LA	24	6	54	42,0	GA.43A	BA.46A	100	21	1,050
NM.26LA	26	6	54	44,5	GA.43A	BA.46A	100	24	1,080
NM.27LA	27	6	54	46,0	GA.43A	BA.46A	100	24	1,120
NM.29LA	29	6	54	48,0	GA.43A	BA.46A	100	24	1,200
NM.30LA	30	6	54	50,0	GA.43A	BA.46A	100	24	1,200
NM.32LA	32	6	54	52,0	GA.43A	BA.46A	100	24	1,250
NM.33LA	33	6	54	53,0	GA.43A	BA.46A	100	24	1,320
NM.34LA	34	6	54	55,0	GA.43A	BA.46A	100	40	1,320
NM.35LA	35	6	54	56,0	GA.43A	BA.46A	100	60	1,340
NM.36LA	36	6	54	57,0	GA.43A	BA.46A	100	65	1,500
NM.38LA	38	6	54	60,0	GA.43A	BA.46A	100	65	1,500
NM.41LA	41	6	54	63,0	GA.43A	BA.46A	100	64	1,650
NM.42LA	42	6	54	65,0	GA.43A	BA.46A	100	64	1,650
NM.46LA	46	6	54	70,0	GA.43A	BA.46A	100	63	1,560
NM.50LA	50	6	54	75,0	GA.43A	BA.46A	100	62	1,870
NM.54LA	54	6	54	80,0	GA.43A	BA.46A	100	61	1,780
NM.55LA	55	6	54	81,0	GA.43A	BA.46A	100	60	1,930
NM.58LA	58	6	54	85,0	GA.43A	BA.46A	105	65	2,120
NM.60LA	60	6	54	87,0	GA.43A	BA.46A	120	78	2,180
NM.65LA	65	6	54	93,0	GA.43A	BA.46A	125	80	2,250
NM.70LA	70	6	54	100,0	GA.43A	BA.46A	125	80	2,230

NMB - Nasadki udarowe 1" długie 6-kątne cienkościenne metryczne

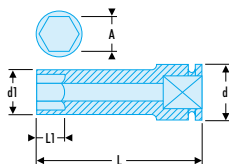

NF ISO 2725-2, NF ISO 1711-2, ISO 2725-2, ISO 1711-2, DIN 3129, ASME B107.33

- Cienkie ścianki umożliwiające pracę w miejscach trudno dostępnych.
- Dla Państwa bezpieczeństwa należy zawsze używać nasadek udarowych z odpowiednimi pierścieniami i kołkami zabezpieczającymi.
- Profil 6-kątny wypukły dla lepszej wytrzymałości.

⇒	A [mm]	⌀ [mm]	d [mm]	d1 [mm]	GA	BA	L [mm]	L1 [mm]	ΔΔ [kg]
NMB.24	24	6	54	38	GA.43A	BA.46A	108	24	0,940
NMB.27	27	6	54	42	GA.43A	BA.46A	108	27	1,000
NMB.30	30	6	54	46	GA.43A	BA.46A	108	30	1,040
NMB.32	32	6	54	48	GA.43A	BA.46A	108	32	1,040
NMB.33	33	6	54	49	GA.43A	BA.46A	108	33	1,050
NMB.36	36	6	54	53	GA.43A	BA.46A	108	36	1,080
NMB.46	46	6	54	66	GA.43A	BA.46A	108	38	1,480
NMB.50	50	6	54	74	GA.43A	BA.46A	108	66	1,480



■ NM.ELA - Nasadki udarowe 1" ekstra-długie 6-kątne metryczne

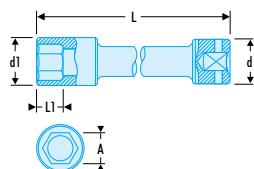

- Dla Państwa bezpieczeństwa należy zawsze używać przedłużaczy udarowych z odpowiednimi pierścieniami i kołkami zabezpieczającymi.

⇒	A [mm]	⌀ [mm]	d [mm]	d1 [mm]	GA	BA	L [mm]	L1 [mm]	ΔΔ [kg]
NM.30ELA	30	6	54	50	GA.43A	BA.46A	270	30	2,50
NM.32ELA	32	6	54	52	GA.43A	BA.46A	270	32	2,56
NM.33ELA	33	6	54	53	GA.43A	BA.46A	270	32	2,56

■ Nasadka udarowa 1" „Traylor”, metryczna

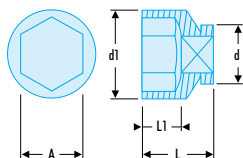

- Dla Państwa bezpieczeństwa należy stosować pierścieni BA.46A i kołek GA.43A.
- Do nakrętek piast Traylor, 6-kątna, 77 mm.

⇒	A [mm]	d [mm]	d1 [mm]	L [mm]	L1 [mm]	ΔΔ [kg]
M.77TR	77	54	106	81	35	1,96

■ NM.A - Przedłużacze udarowe 1"

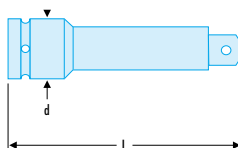

ASME B107.2

- Dla Państwa bezpieczeństwa należy zawsze używać przekładni udarowych z odpowiednimi pierścieniami i kołkami zabezpieczającymi.

⇒	d [mm]	GA	BA	L [mm]	ΔΔ [kg]
NM.209A	54	GA.43A	BA.46A	125	1,20
NM.210A	54	GA.43A	BA.46A	200	1,60
NM.215A	54	GA.43A	BA.46A	330	2,50



NG.A - Przedłużacze udarowe 1"1/2

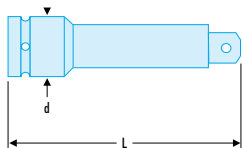

ASME B107.2

- Dla Państwa bezpieczeństwa należy zawsze używać przedłużaczy udarowych z odpowiednimi pierścieniami i kołkami zabezpieczającymi.

	d [mm]	GA	BA	L [mm]	$\Delta\Delta$ [kg]
NG.210A	86	GA.75A	BA.75A	250	5,60
NG.215A	86	GA.75A	BA.75A	330	6,80

Przegub udarowy 1"1/2

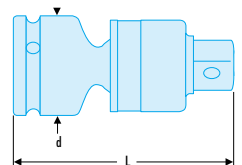

ASME B107.2

- Dla Państwa bezpieczeństwa należy zawsze używać przegubów udarowych z odpowiednimi pierścieniami i kołkami zabezpieczającymi.

	d [mm]	GA	BA	L [mm]	$\Delta\Delta$ [kg]
NG.240A	86	GA.75A	BA.75A	181	4,20

Przełożenie udarowe z 1" 1/2 do 2"1/2

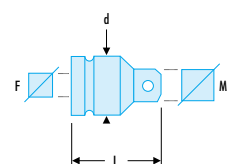

ASME B107.2

- Dla Państwa bezpieczeństwa należy zawsze używać przegubów udarowych z odpowiednimi pierścieniami i kołkami zabezpieczającymi.

	Kwadrat ["]	d [mm]	GA	BA	L [mm]	$\Delta\Delta$ [kg]
NG.232A	F = 1" 1/2 - M = 2"1/2	86	GA.75A	BA.75A	120	3,90

Reduktor udarowy z 1"1/2 do 1"

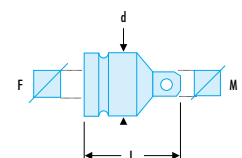

ASME B107.2

- Dla Państwa bezpieczeństwa należy zawsze używać przegubów udarowych z odpowiednimi pierścieniami i kołkami zabezpieczającymi.

	Kwadrat ["]	d [mm]	GA	BA	L [mm]	$\Delta\Delta$ [kg]
NG.230A	F = 1" 1/2 - M = 1"	80	GA.75A	BA.75A	98	2,166

▣ Klucz udarowy Dynapact 3/4"

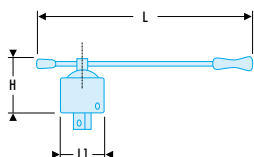

- Klucz z zasobem energii do mocnego dokręcania lub skutecznego odkręcania.
- Podziałka kątowna potrzebna do wyzwolenia udaru (około 60°).
- Moment przekazywany ścianie nakrętki 21 mm: 1000 Nm po 10 wyzwoleniach.

- Rękojeść Dynapact: NK.300M.

	H [mm]	L [mm]	L1 [mm]	ΔΔ [kg]
NK.300	105	470	96	4,00

▣ NK.301AE Zestaw Dynapact 3/4"



- Zawiera:
 - Klucz udarowy NK.300 z 16 narzędziami, pierścieniem i kołkiem blokującym.
 - Nasadki: NK.19A - NK.21A - NK.22A - NK.23 A - NK.24A - NK.26A - NK.27A - NK.29A - NK.30A - NK.32A - NK.34A - NK.36A - NK.38A - NK.41A - NK.42A.
 - Przedłużacz: NK.210A.
 - Skrzynka metalowa BT.103G, wym. (dł. x gł. x wys.): 643 x 224 x 111 mm.
 - Wkładka PL.84A.
- Masa: 16,70 kg.

▣ Klucz udarowy Dynapact 1"

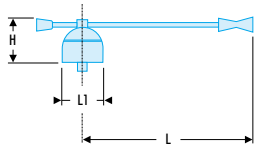

- Klucz z zasobem energii do mocnego dokręcania i skutecznego odkręcania.
- Podziałka kątowna potrzebna do wyzwolenia udaru (około 60°).
- Moment przekazywany ścianie nakrętki 21 mm: 2000 Nm po uderzeniach.

- Rękojeść Dynapact: NM.300M.

	H [mm]	L [mm]	L1 [mm]	ΔΔ [kg]
NM.300	140	595	125	10,80

